

Revision D: This document supersedes previous revisions.
Revised as per DA comments. Image of sensors location added among other things.

ENGINE HARNESS REPLACEMENT – OIL SEEPAGE AT UNIT INJECTOR PASS-THROUGH FITTING

Prevost vehicles

DESCRIPTION

On the vehicles affected by this bulletin, replace the engine harness as described in the following procedure.

MODEL YEAR(S) AND VEHICLES INVOLVED

<i>NOTICE TO SERVICE CENTERS</i>	
<i>Verify vehicle eligibility by checking warranty bulletin status with SAP or via ONLINE WARRANTY SYSTEM available on Service / Warranty tab of Prevost website.</i>	
Model	VIN
X3-45 Commuter Model Year : 2012	From 2PCG33495CC73 <u>5053</u> up to 2PCG33495CC73 <u>5232</u> incl.
<p>This bulletin does not necessarily apply to all the above-mentioned vehicles, some vehicles may have been modified before delivery. The owners of the vehicles affected by this bulletin will be advised by a letter indicating the Vehicle Identification Number (VIN) of each vehicle concerned.</p>	

MATERIAL NEEDED

Order the following parts:

Part No.	Description	Qty
983472	CABLE TIE, HIGH TEMPERATURE – UNDER VALVE COVER	6
20538793	GASKET, VALVE COVER	1
21532258	O-RING, BREATHER TUBE	1
22218700	ENGINE HARNESS	1

Other parts that may be required:

Part No.	Description	Qty
504637	CABLE TIE, NYLON	A-R
967343	O-RING, EGR CROSSOVER PIPE	1
8131393	RETAINER	4
20504408	CLAMP, V-BAND	1

NOTE

Material can be obtained through regular channels.

PROCEDURE



DANGER

Park vehicle safely, apply parking brake, stop engine. In the battery box, set the battery cut-off switch to the OFF position prior to working on the vehicle.

NOTE

When performing removal of the existing engine harness, disconnect the exterior connectors first and finish with the connectors located under the valve cover in order to avoid prolonged period of time with cylinder head unprotected from dirt or foreign matter.





NOTE

One after the other, unplug the engine harness connectors, starting with the connectors found outside of the engine block.

When necessary, clean the area around the connector to protect connector from dust and foreign matter.

If necessary, identify each connecting points around the engine to ease installation of the replacement harness.

REQUIRED TOOLS

<p>TORQUE WRENCH AND METRIC SOCKET SET</p> 	<p>RATCHET AND SOCKET SET – METRIC SET</p> 
<p>RTV GASKET MAKER</p> 	<p>CUTTING PLIERS</p> 

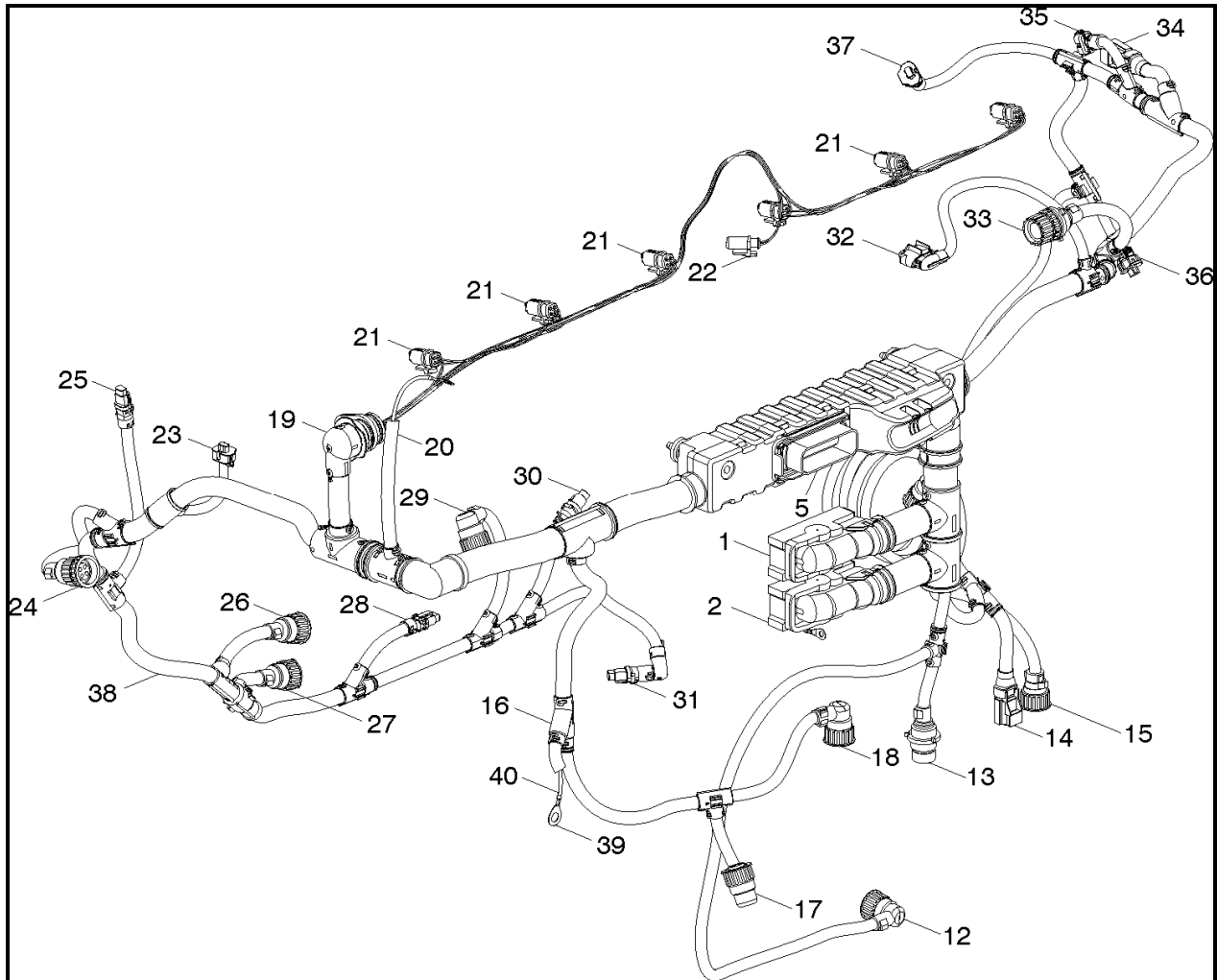

FIGURE 1: ENGINE HARNESS

12 sensor, oil level & temperature
 13 aftertreatment sensor
 14 sensor, pressure crankcase
 15 sensor, oil pressure
 16 -
 17 solenoid valve, DRV
 18 sensor, fuel pressure
 19 pass-through
 20 preheater, engine
 21 unit injectors
 22 solenoid valve, VEB
 23 sensor, coolant temp
 24 sensor, EGR
 25 sensor, temp EGR
 26 sensor, turbo speed

27 VGT
 28 sensor, comp discharge temp
 29 sensor, oil cooling
 30 oil thermostat
 31 oil piston cooling jet
 32 sensor, boost temp
 33 CAN3
 34 7th injector
 35 solenoid valve, EGR
 36 sensor, engine speed camshaft
 37 sensor, engine speed crankshaft
 38 -
 39 ring terminal
 40 electrical cable

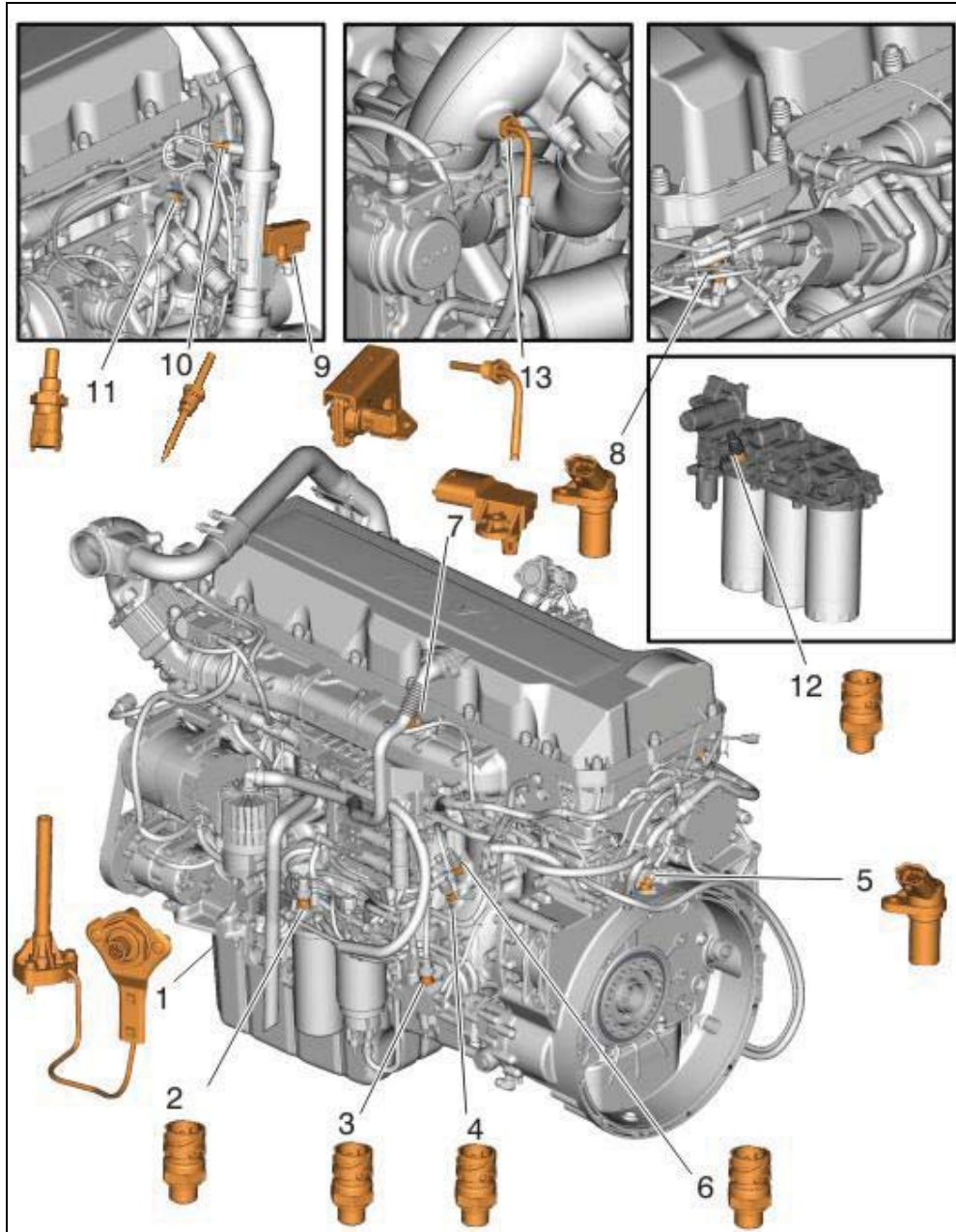

FIGURE 2: ENGINE SENSORS LOCATION

1 Engine Oil Level/Temperature	8 Camshaft Speed
2 Fuel Pressure	9 Exhaust Gas Recirculation (EGR) Diff. Pressure
3 Aftertreatment Fuel Pressure	10 EGR Temperature
4 Engine Oil Pressure (EOP)	11 Engine Coolant Temperature (ECT)
5 Crankshaft Speed	12 Piston Cooling Jet Oil Pressure Sensor
6 Crankcase Pressure (CCP)	13 Compressor Discharge Temperature Sensor
7 Intake Air Temperature/Pressure	

PROCEDURE

1. Inside the coach, remove the floor access panel.
2. Remove the EGR crossover pipe (3 clamps, fig.3).

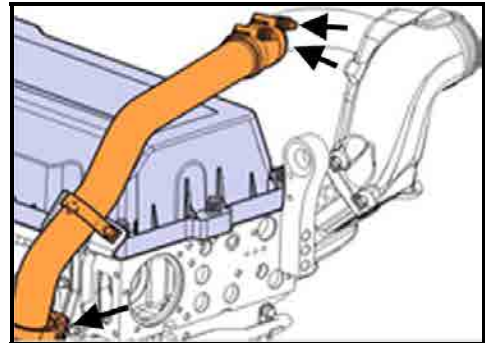

FIGURE 3

3. Remove the clamp and disconnect the air compressor inlet hose.
4. Remove the hose clamps (2 clamps, fig.4) at the air filter housing and the turbocharger inlet. Remove the air intake pipe as an assembly.

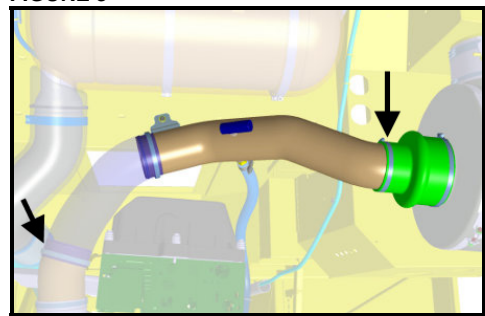

FIGURE 4

5. Remove the crankcase ventilation tube from the valve cover (fig.5) and crankcase ventilation separator.

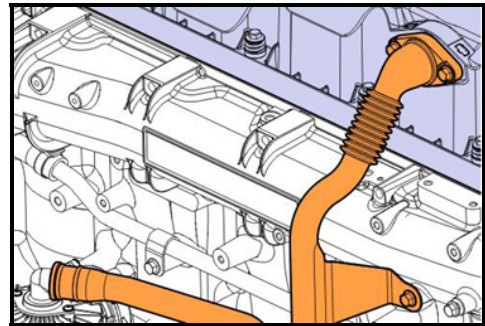

FIGURE 5

6. Disconnect the engine harness connections on the hot side of the engine (fig. 1, 2 & 6). Remove all nylon cable ties and P-clamps.

- a) Turbine Shaft Speed Sensor
- b) VGT (Variable Geometry Turbocharger Actuator)
- c) EGR Temperature Sensor
- d) Engine Coolant Temperature Sensor
- e) Comp. Discharge Temperature Sensor
- f) Oil Cooling Sensor
- g) Oil Level & Temperature Sensor
- h) Oil piston cooling jet

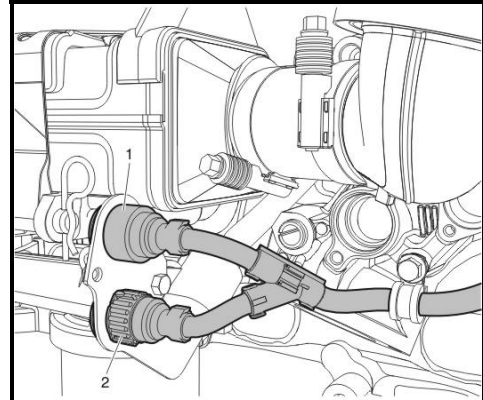

FIGURE 6

1) VGT

2) Turbine Shaft Speed Sensor

7. Move the harness from the hot side of the engine to the front of the engine.

8. In the rear junction box, disconnect the starter wires from the starter relay solenoid terminals and remove all nylon cable ties (fig.7).



FIGURE 7

9. Disconnect the following rear engine harness connections: camshaft position sensor, crankshaft position sensor, and exhaust gas recirculation (EGR) valve (fig.8). Remove P-clamps.

10. Remove all nylon cable ties and P-clamps holding the harness to the rear of the engine. Move the harness from the rear of the engine to the cold side of the engine.

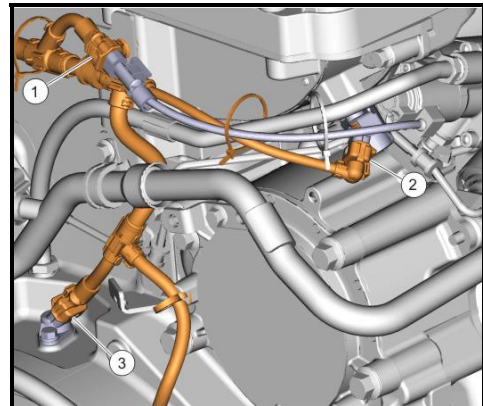

FIGURE 8

1) Exhaust Gas Recirculation (EGR) Valve

2) Camshaft Position Sensor

3) Crankshaft Position Sensor

11. Disconnect the intake air temperature/ pressure sensor (fig.9). Remove all nylon cable ties and P-clamps.

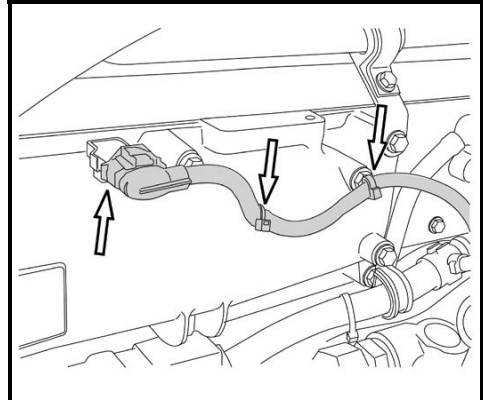

FIGURE 9

12. Disconnect the following cold side middle harness connections (fig.10). Remove P-clamps.
- a) Crankcase Pressure Sensor
 - b) Oil Pressure Sensor
 - c) Aftertreatment Hydrocarbon Dosing Module
 - d) Aftertreatment Fuel Pressure Sensor

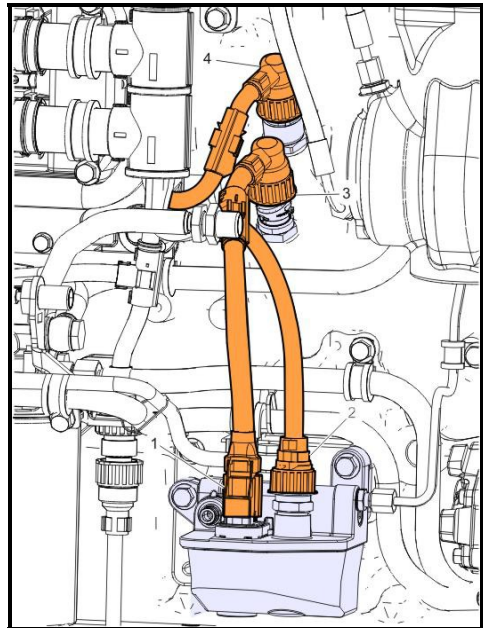

FIGURE 10

- 1) Aftertreatment Hydrocarbon Dosing Module
- 2) Aftertreatment Fuel Pressure Sensor
- 3) Oil Pressure Sensor
- 4) Crankcase Pressure Sensor

13. Disconnect the harness from the engine oil level/temperature sensor and water separator connector on the cold side of the engine (fig.11). Remove all nylon cable ties and P-clamps.

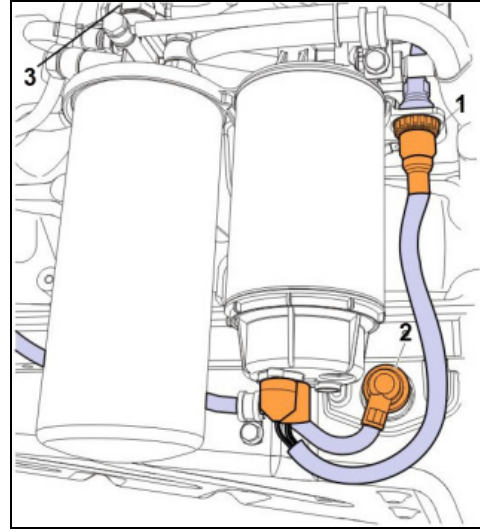

FIGURE 11

- 1) Fuel/Water Separator
- 2) Engine Oil Level/Temperature Sensor
- 3) Fuel Pressure Sensor

14. Disconnect the ECM and vehicle harness connections (fig. 12). Remove all nylon cable ties and P-clamps.

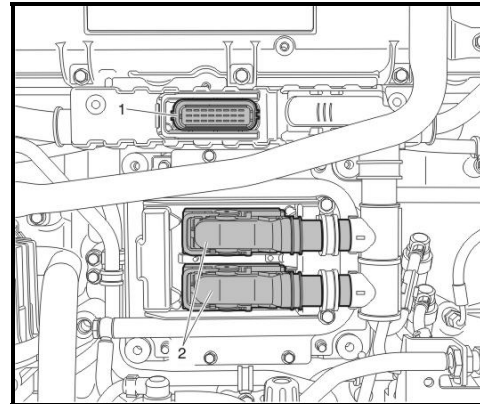

FIGURE 12

- 1) Vehicle Harness Connector
- 2) Engine Control Module (ECM) Connectors

15. Disconnect the ground connection from the block, fuel pressure sensor connection (fig.11, item 3), and the harness ground wire ring terminal from the block behind the alternator. Remove all nylon cable ties and P-clamps.
16. Disconnect the harness from the data link connector. If equipped, disconnect the preheater control wires. Remove all nylon cable ties and P-clamps.
17. Remove the valve cover fasteners and remove the valve cover from the engine.
18. Cover the valve mechanism and gear train as required, to

prevent dirt and debris from entering the engine.

19. If equipped, cut the nylon cable tie securing the wiring harness to the engine compression brake actuator (fig. 13).

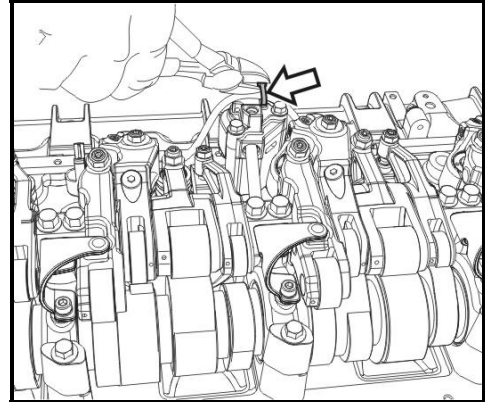

FIGURE 13

20. Disconnect the harness from the engine injectors (fig. 14).

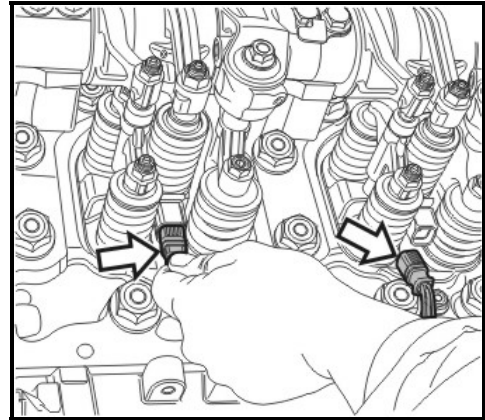

FIGURE 14

21. Disconnect the cylinder head pass through fastener. Carefully remove the harness from the pass through (fig. 15).

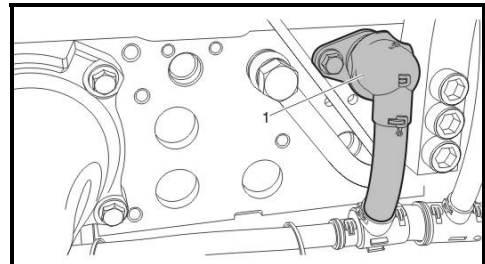

FIGURE 15

1) Pass Through

22. Unscrew harness box fasteners. Remove the engine harness from the engine.

INSTALLATION

1. Install and secure the harness box and fasteners.
2. Carefully guide the harness into the pass through and position it on the cylinder head. Route the connectors to each of the unit injectors.
3. Connect the harness to the unit injectors (fig. 16). Push the connector until a distinct “click” is heard to ensure the connector is fully engaged.
4. Use high temperature cable ties #983472 to secure the harness to the retainers #8131393 on the cylinder head.

Note: It is extremely important that the head of the cable ties face downward to prevent contact with the valve cover.

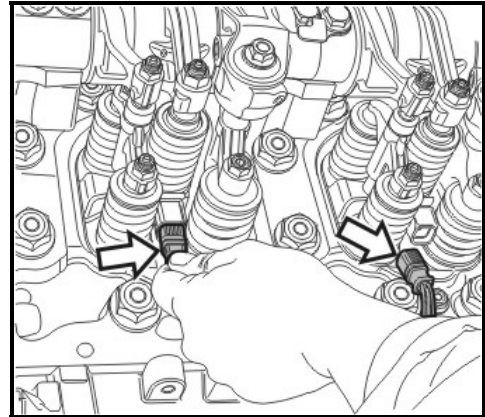

FIGURE 16

5. Clean the gasket sealing surface of the cylinder head. The surfaces should be clear of any dirt or debris and free of any oil.

Note: Remove any sealant from the joint between the cylinder head and upper timing gear cover.

6. Remove the old rubber gasket from the valve cover channel. Carefully place the new gasket #20538793 into the channel, making sure that it's properly seated and follows the contour of the channel.
7. Apply a 2 mm (0.079 in) bead of sealant at the joint of the timing cover and the cylinder head on both sides.

Note: The valve cover must be installed within 20 minutes of the application of the sealant.

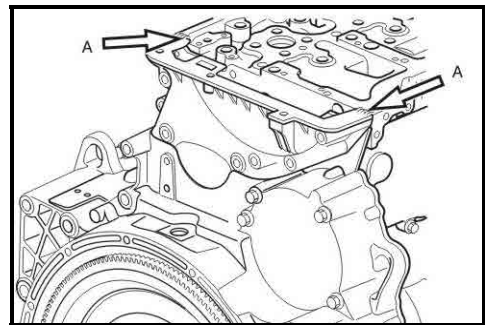

FIGURE 17

8. Carefully position the valve cover on the cylinder head and ensure that the seal remains properly seated.
9. Install the spring-loaded bolts in the valve cover. Torque-tighten the valve cover bolts to 24 ± 4 Nm (18 ± 3 ft-lb) in the sequence shown (fig. 18).

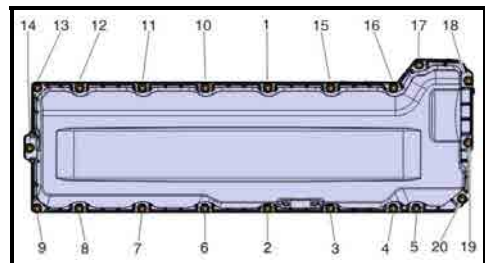

FIGURE 18

10. Install the pass through fastener (fig. 19). Tighten the cap screw to 24 Nm (18 ft-lb).

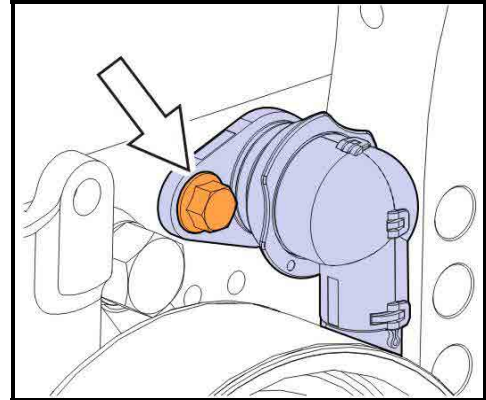

FIGURE 19

1) Pass Through

11. Connect the harness to the intake manifold air temperature/pressure sensor on the intake manifold (fig. 20). Install nylon cable ties and P-clamps as necessary.

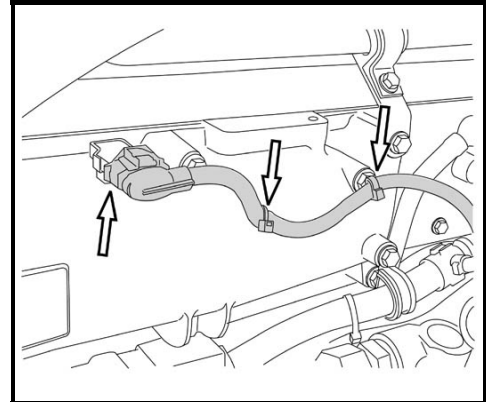

FIGURE 20

12. Connect the harness to the data link connection. If equipped, connect the preheater control wires. Install nylon cable ties and P-clamps as necessary.
13. Connect the harness to the fuel pressure sensor (fig.22, item 3), ground connection to the block, and the harness ground wire ring terminal to the block behind the alternator. Install nylon cable ties and P-clamps as necessary.
14. Connect the harness to the ECM and vehicle harness connections on the cold side of the engine (fig. 21). Install nylon cable ties and P-clamps as necessary.

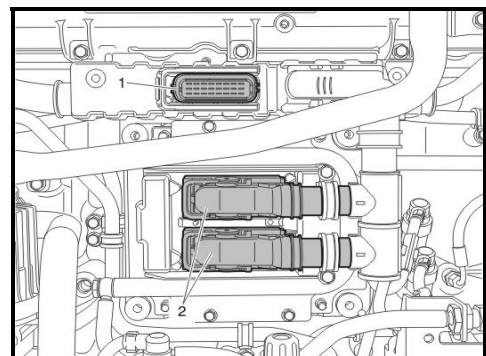

FIGURE 21

1) Vehicle Harness Connector

2) Engine Control Module (ECM) Connectors

15. Connect the harness to the engine oil level/temperature sensor and water separator connector on the cold side of the engine (fig. 22). Install nylon cable ties and P-clamps.

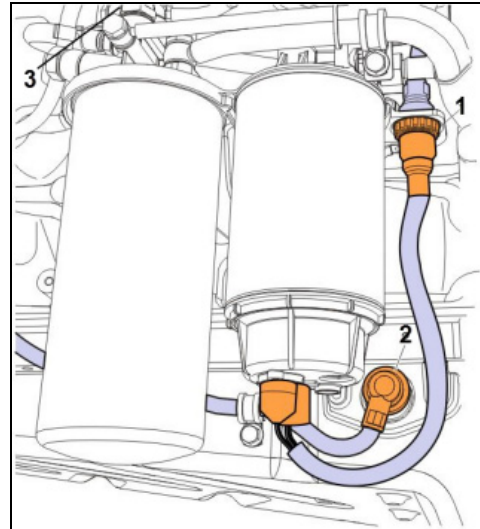

FIGURE 22

- 1) Fuel/Water Separator
- 2) Engine Oil Level/Temperature Sensor
- 3) Fuel Pressure Sensor

16. Connect the harness connections (fig. 23). When applicable, secure harness with existing P-clamps.
- a) Crankcase Pressure Sensor
 - b) Oil Pressure Sensor
 - c) Aftertreatment Hydrocarbon Dosing Module
 - d) Aftertreatment Fuel Pressure Sensor

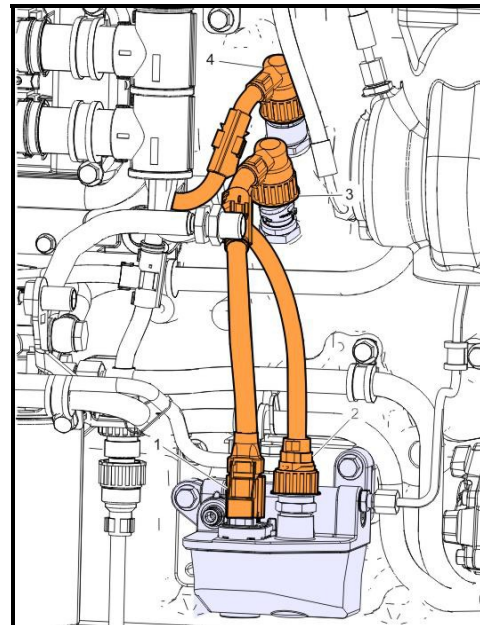

FIGURE 23

- 1) Aftertreatment Hydrocarbon Dosing Module.
- 2) Aftertreatment Fuel Pressure Sensor.
- 3) Oil Pressure Sensor.
- 4) Crankcase Pressure Sensor.

17. Put the rear section of the engine harness in place. Connect the following rear engine harness connections (fig. 24). Start to attach P-clamps.

- a) Exhaust Gas Recirculation (EGR) Valve
- b) Camshaft Speed Sensor
- c) Crankshaft Speed Sensor

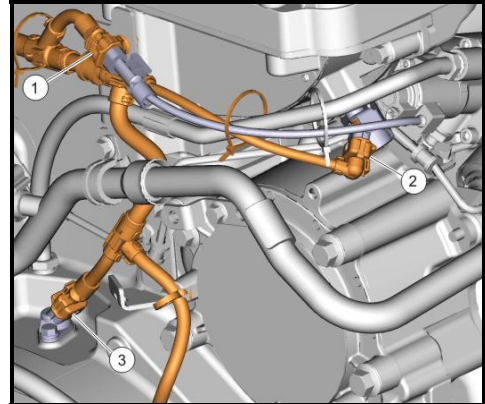

FIGURE 24

- 1) Exhaust Gas Recirculation (EGR) Valve
- 2) Camshaft Position Sensor
- 3) Crankshaft Position Sensor

18. In the rear junction box, connect the starter wires to the starter relay solenoid terminals. Install nylon cable ties as necessary.



FIGURE 25

19. Connect the engine harness connections on the hot side of the engine. Install nylon cable ties and P-clamps as necessary (fig. 26).

- a) Turbine Shaft Speed Sensor
- b) Engine Variable Geometry Turbocharger Actuator
- c) EGR Temperature Sensor
- d) Engine Coolant Temperature Sensor
- e) Comp. Discharge Temperature Sensor
- f) Oil Cooling Sensor
- g) Oil Level & Temperature Sensor
- h) Oil piston cooling jet

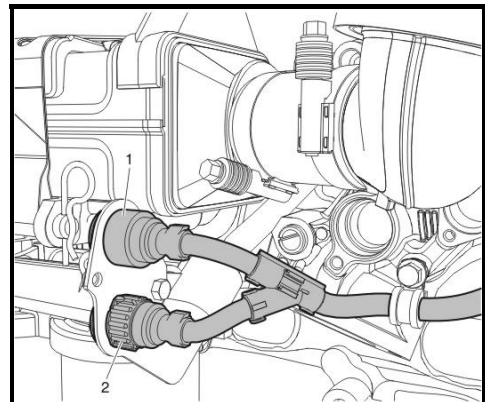

FIGURE 26

- 1) Engine Variable Geometry Turbocharger Actuator

2) Turbine Shaft Speed Sensor

20. Install the crankcase ventilation tube with new O-ring #21532258. Install the fasteners securing crankcase ventilation tube and bracket to valve cover and intake manifold (fig. 27). Torque-tighten fasteners to 24 ± 4 Nm (18 ± 3 ft-lb).

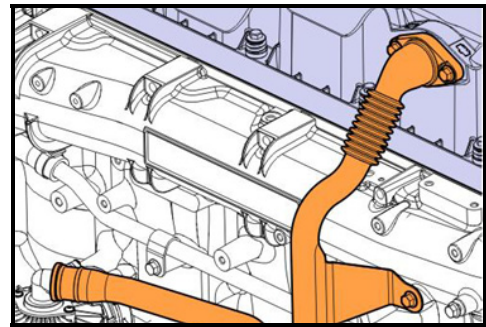

FIGURE 27

21. Install the air intake pipe assembly. Install the hose clamps at the air filter housing and the turbocharger inlet (fig.28). Position the clamps and tighten to secure.
22. Install the air compressor inlet hose and clamp. Tighten to secure.

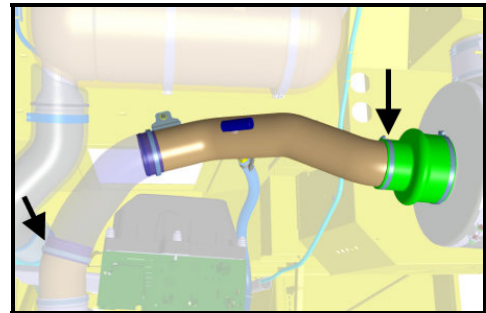

FIGURE 28

23. Position the crossover pipe with new O-ring #967343. Make sure the O-ring is in place and install the V-band clamp (fig.29). Torque-tighten fasteners to specification.

V-band clamp: 7 ± 1 lbf-ft

Other clamps (2): 62 ± 9 lbf-in

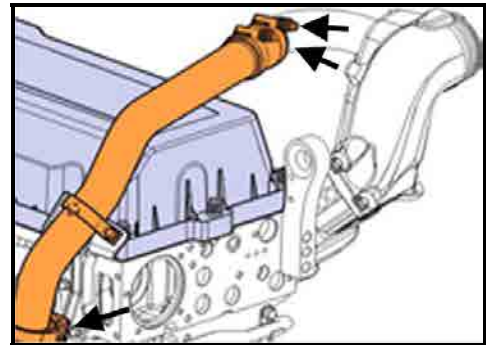

FIGURE 29

24. Install the floor access panel.
25. Connect the power and ground cables to the batteries. Install the battery cover and close the battery compartment door.
26. Check Operation: Start Engine. Check for leaks. Check Operation using Tech Tool, check for Codes.

Date	Expiration	Release	Page
05.2014	05.2016	5	15(15)

PARTS / WASTE DISPOSAL

Return replaced parts to Prevest with A.F.A. for full reimbursement.

ESTIMATED TIME

The time required to perform this special bulletin is approximately 10 hour.

OTHER

VBC Bulletin	S6381
Fail Code	01.00-2
Defect Code	09
System Condition	B
Causal Part	21570897

Prevest engages in a continuous program of testing and evaluating to provide the best possible product. Prevest, however, is not committed to, or liable for updating existing products.