



Carpet Pulls Out From Under the Door Sill Trim

(Supersedes 09-072, dated September 18, 2009, to revise the information marked by the black bars)

REVISION SUMMARY

In Applies To, 2010 through 2012 models were added.

SYMPTOM

The passenger's side carpet pulls out from underneath the door sill trim when you step into the car.

PROBABLE CAUSE

The edge of the carpet is not firmly attached to the body.

CORRECTIVE ACTION

Re-attach the carpet edge to the body using double-sided tape.

REQUIRED MATERIALS

3M Double Faced Automotive Attachment Tape:
P/N 3M 051131-06381 (one roll will repair approximately 65 vehicles).

WARRANTY CLAIM INFORMATION

In warranty: The normal warranty applies.

Operation Number: 8470A1

Flat Rate Time: 0.2 hour

Failed Part: P/N 83301-TA5-A01ZA

Defect Code: 05701

Symptom Code: 07302

Template ID: 09-072A

Skill Level: Repair Technician

REPAIR PROCEDURE

1. Remove the passenger's side door sill trim. (4-door shown, 2-door similar)

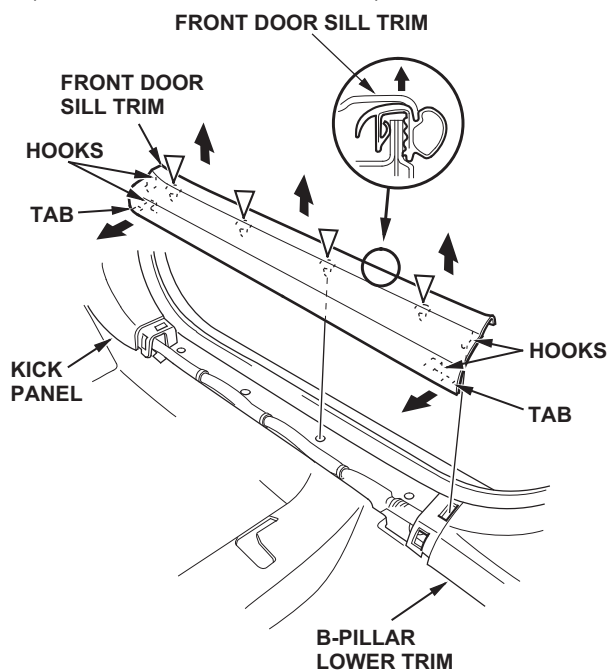

CUSTOMER INFORMATION: The information in this bulletin is intended for use only by skilled technicians who have the proper tools, equipment, and training to correctly and safely maintain your vehicle. These procedures should not be attempted by "do-it-yourselfers," and you should not assume this bulletin applies to your vehicle, or that your vehicle has the condition described. To determine whether this information applies, contact an authorized Honda automobile dealer.

2. Unfasten the rear carpet clip from the body.
3. Cut a 270 mm (10.5 inches) strip of 3M double-sided tape, and apply it to the body starting at the front carpet clip and along the edge of the wire harness.



4. Peel back about 50mm (2 inches) of the tape backing starting at the front carpet clip.

① Peel back 50 mm of the tape backing.



② Refasten the rear carpet clip.

5. Fasten the rear carpet clip back into place, and finish removing the rest of the tape backing.

6. Pull the carpet tight, as far past the edge of the tape as possible. Then press the carpet down, along its entire length, to make firm contact with the tape.

Pull the carpet past the tape and press down.

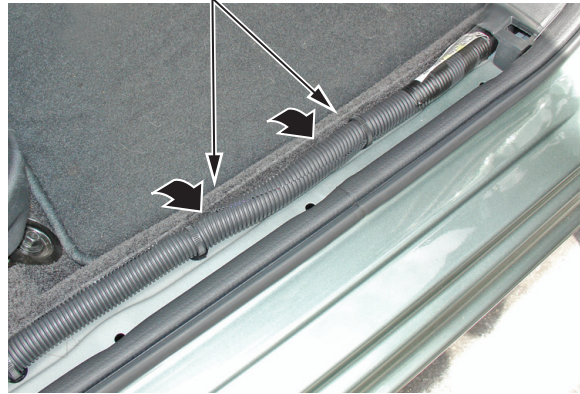

7. Reinstall the passenger's side carpet trim.
8. Allow the repair to set for an hour before testing.
9. Test the repair by sitting in the passenger's seat and pushing down on the side wall of the carpet with your foot.

