

1 2 29-14



Service Information Bulletin

SUBJECT	DATE
Symptom Based Diagnostics - Oil Separator	February 2014

Additions, Revisions, or Updates

Publication Number / Title	Platform	Section Title	Change
DDC-SVC-MAN-0084	DD Platform	Symptom Based Diagnostics - Oil Separator	New Section



13400 Outer Drive, West, Detroit, Michigan 48239-4001
 Telephone: 313-592-5000
www.demanddetroit.com

2 Symptom Based Diagnostics - Oil Separator

Check as follows:

1. Are there external leaks on the cylinder block where the oil separator feed tube (2) is mounted?
 - a. Yes; repair tube and seals as necessary.
 - b. No; Go to step 2.
2. Are there external leaks at the base of the oil separator where it mounts to the cylinder crankcase (1)?
 - a. Yes; replace the oil separator mounting gasket. Refer to section "Removal of the Crankcase Breather" and Refer to section "Installation of the Crankcase Breather".
 - b. No; Go to step 3.

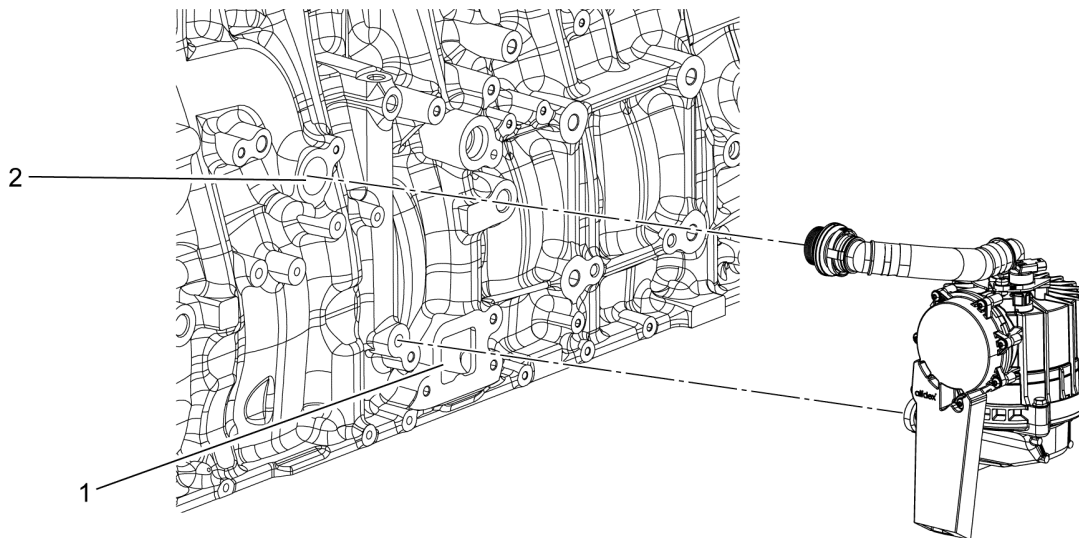

d010147

3. Remove the seven mounting screws securing the vent to the oil separator.

NOTE: A normal vent will have a very thin film of oil inside the outlet.

4. Is there oil sludge built up in the vent (1)?
 - a. Yes; replace the oil separator.
 - b. No; Go to step 5.

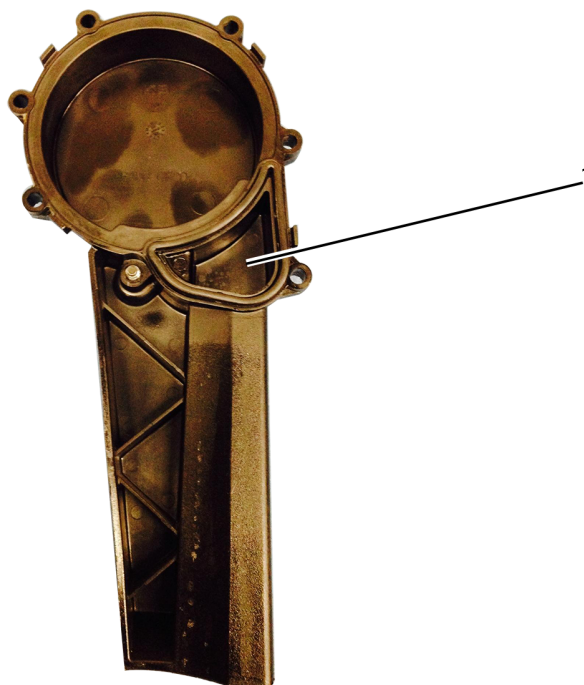

d010149

5. Install the vent. Torque bolts to 4.4 N·m (39 lb·in.).
6. Conduct an oil dye test. Refer to section "Engine Oil Leaks - Oil Dye Method"
7. Is the oil dye leaking from the oil separator housing?
 - a. Yes; replace the oil separator.
 - b. No; inspect other areas of the engine for oil dye. Repair as necessary.