



Service Bulletin

File in Section: -

Bulletin No.: PI1376

Date: December, 2014

PRELIMINARY INFORMATION

Subject: Front Seat Lateral Movement and/or Click Type Noise While Driving

Models: 2015 Cadillac Escalade Models
2015 Chevrolet Silverado, Suburban, Tahoe
2015 GMC Sierra, Yukon Models

Condition/Concern

Some customers may comment that the driver and/or passenger seat lower cushion exhibits excessive lateral seat movement combined with a clunk type feeling, or generates a click type noise. This condition occurs when the seat is occupied and the vehicle is being driven on roads with multiple curves or during low speed maneuvers.

This condition may be caused by movement between the seat pan front pivot points and the seat frame pivot bar. The plastic attachment points may “stick” then “slip” creating the condition. There may also be excessive clearance between the power seat vertical adjuster actuator and the attachment point on the seat frame.

Recommendation/Instructions

Use the following steps to lubricate the front seat pan pivot points, add a lateral retainer to the outboard pivot, and install a shim clip between the power seat vertical adjuster actuator and the seat frame (if required) to the affected seat(s):

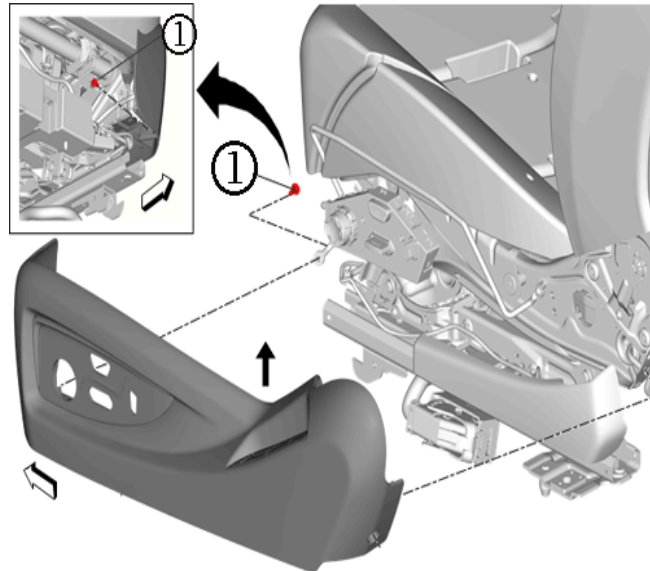

4025118

1. Partially disengage the front seat cushion outer finish cover.
 - Only remove the front seat cushion outer finish cover front fastener (1) as show above.
 - Disengage the cover by pulling upward near the retainer clip locations.

Caution: The front seat cushion outer finish cover rear fastener is still installed, take caution when disengaging the cover.

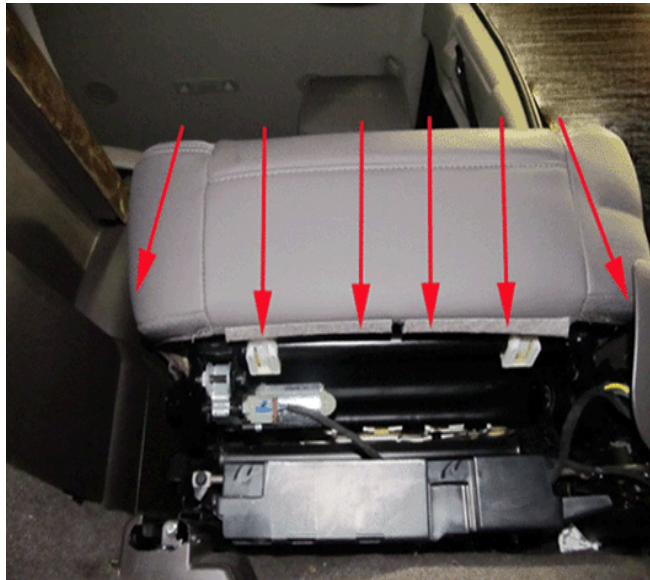

4025189

2. Partially remove the forward half of the lower seat cushion cover and pad on the affected seat.

Note: It is NOT necessary to completely remove the seat cover and pad, only the side and front retainers need to be released. The rear of the cover can remain attached.

- Move the seat into a position where the front and inboard side of the seat cover can be accessed.
- Disengage the front, left and right J-channel retainers from the seat cushion frame as shown above.

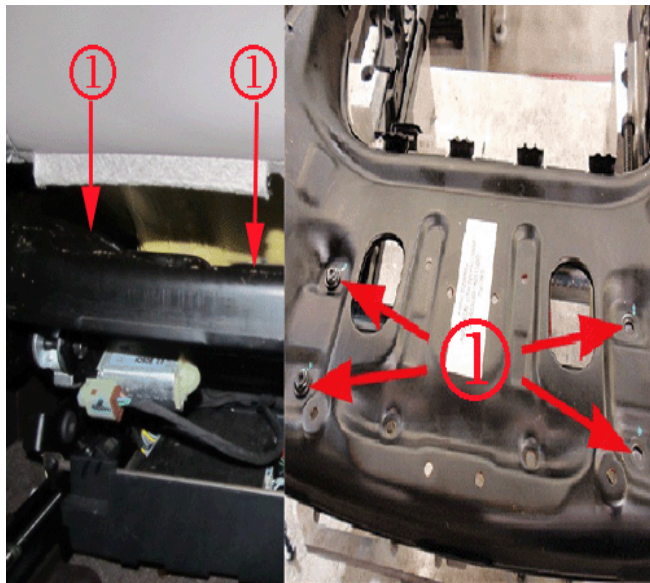

4024923

3. Remove the four screws that attach to the two pivot blocks to the seat pan.

Note: Lift the seat pan to provide additional working access.

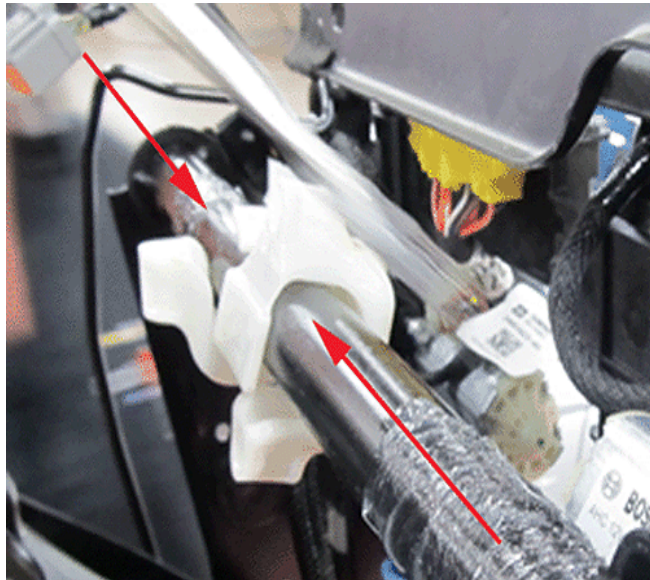

3967501

4. Slide the two pivot blocks to the center of the seat to allow for applying grease to the pivot bar.

Important: DO NOT attempt to remove the pivot blocks from the seat. Possible damage to the pivot blocks may result.

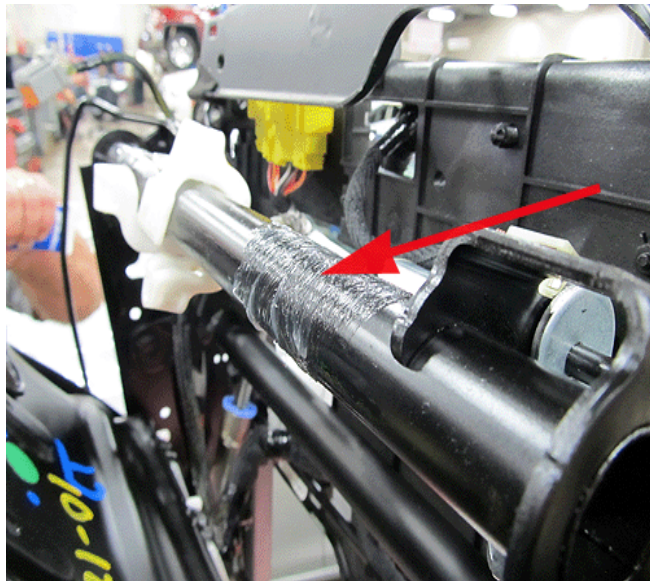

3619960

5. Using a small brush, apply GM Super Lube, GM P/N 12371287 (In Canada, use 10953437) as shown. Ensure the complete contact surface is coated.

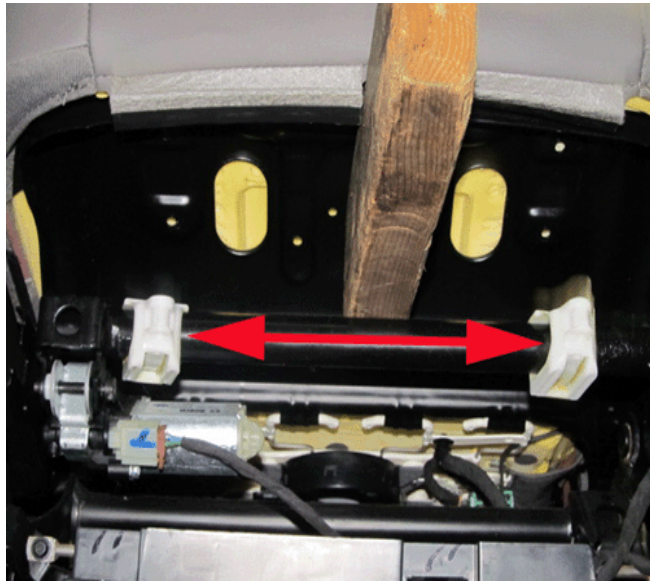

4025748

6. Move the pivot blocks back out to their original position.

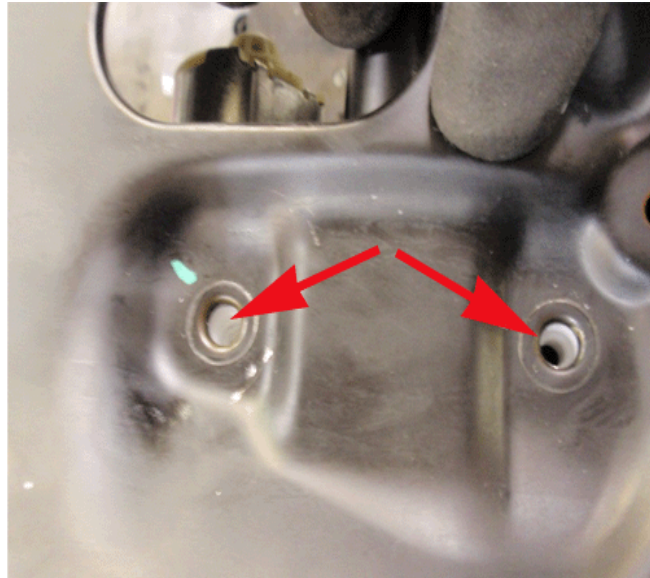

3619963

7. Align the holes in the seat pan with the holes in the pivot blocks.



3619964

8. Hand start the four screws; Do NOT tighten.

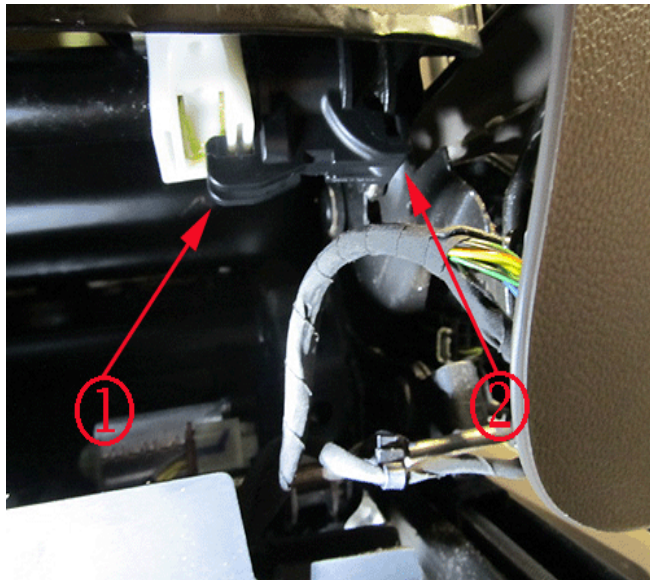

4031854

9. Install the lateral retainer to the outboard end of the pivot bar as shown above. Ensure the retainer is fully seated around the pivot bar and to the pivot block.

Note: The lateral retainer can only be installed one way.

- The double slotted side (1) of the lateral retainer attaches to the pivot block.
- The single slotted side (2) of the lateral retainer attaches to the end of the pivot bar.

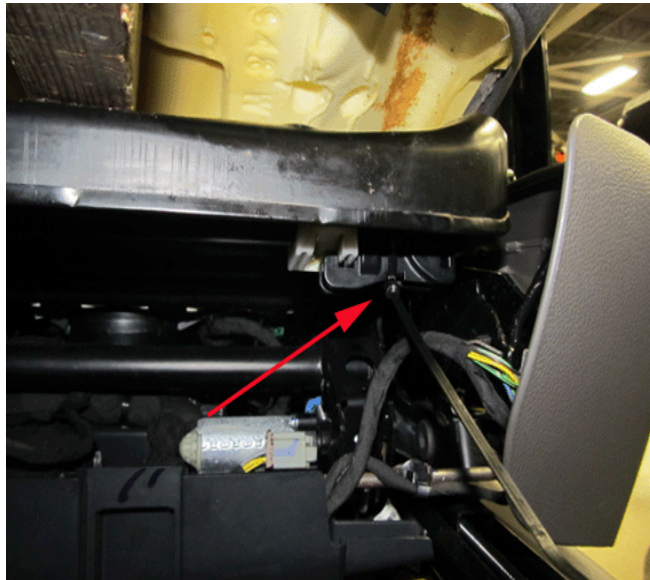

4031857

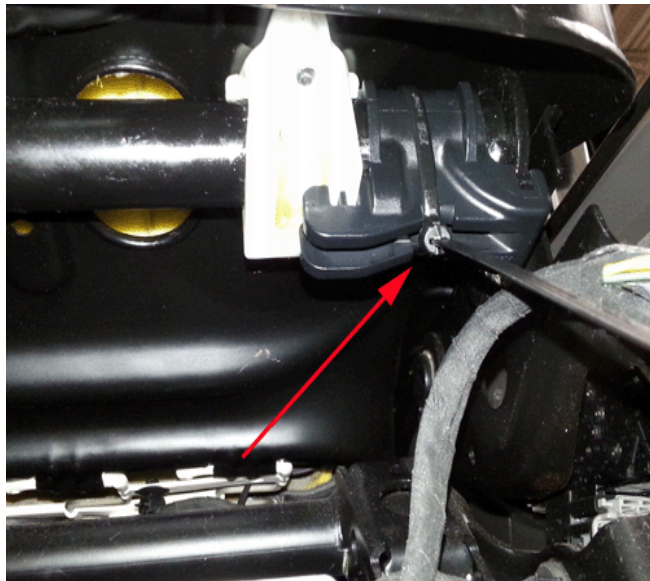

4032701

10. Install a nylon tie strap around the retainer as shown above. Trim the excess tie strap material.
11. Tighten the four screws for the pivot blocks.
12. Wipe off any excess lubricant.
13. Re-install the forward portion of the lower seat cushion cover on the affected seat. Ensure all side and front retainers are fully engaged to the seat frame.

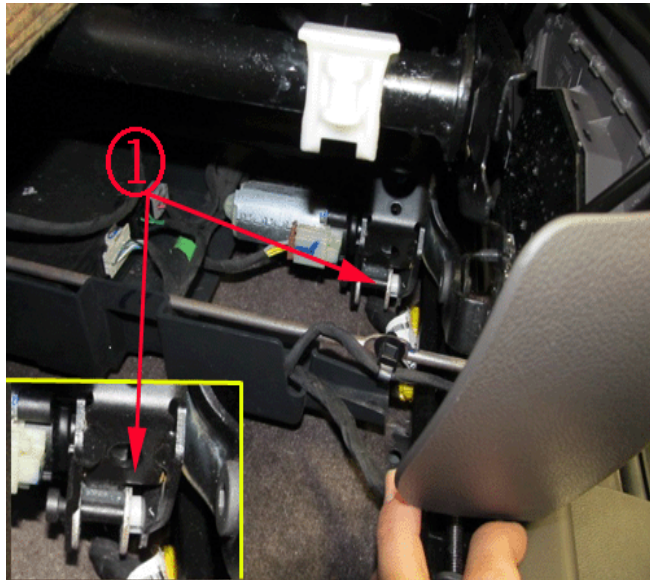

4031883

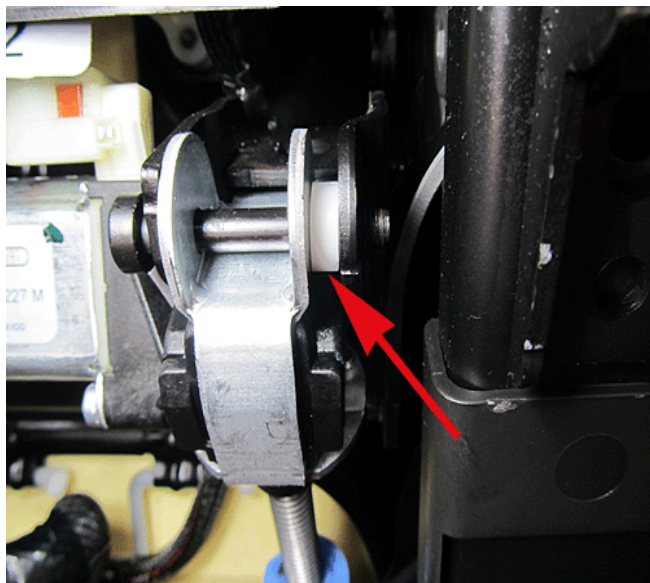

3619968

14. Locate the power seat vertical adjuster actuator attachment to the seat frame.

15. Inspect for the presence of the shim clip (1) as shown.

16. If a shim clip is not present, install the shim clip (1) as shown.

Note: It may be necessary to slightly spread the bracket on the seat frame with a large screwdriver to allow clearance for the clip.

Parts Information

Part Number	Description	Qty
13405675	Front Seat Lateral Retainer	1 per seat
13594989	Shim Clip	1 per seat
12371287 (In Canada, use 10953437)	GM Super Lube 3 oz. Tube	As Required

Warranty Information

For vehicles repaired under the Bumper-to-Bumper coverage (Canada Base Warranty coverage), use the following labor operation. Reference the Applicable Warranties section of Investigate Vehicle History (IVH) for coverage information.

Labor Operation	Description	Labor Time
7080188*	Lubricate Front Seat Pivot Points, Install Lateral Retainer and Install Seat Actuator Shim Clip.	0.6 hr
Add	Perform procedure to both front seats (If Needed)	0.4 hr

*This is a unique Labor Operation for Bulletin use only. It will not be published in the Labor Time Guide.