

Technical Service Bulletin



97AT UPDATE – Fuse (NVLW)

September 18, 2014

Model(s)	Year	VIN Range	Vehicle-Specific Equipment
RS7	2014	See Campaign/Action screen in Elsa	None

Condition

This Update has been proactively released to prevent the following condition from occurring in the vehicle:

On Audi RS7 vehicles manufactured within a certain period an incorrect fuse was installed due to an error in production.

This Update is in effect until removed.

Vehicle must meet all of the following criteria:

- Procedure is valid only for vehicles that show the **97AT** code in the Elsa Campaign/Action Information screen on the day of repair.
- Vehicle must be within the New Vehicle Limited Warranty.
- Procedure must be performed within the allotted time frame stated in this Technical Service Bulletin.
- Procedure must be performed on applicable vehicles in dealer inventory prior to sale.

Technical Background

On Audi RS7 vehicles manufactured within a certain period an incorrect fuse was installed due to an error in production.

Service

1. Using trim stick remove cover <1> on driver side of the dash panel.

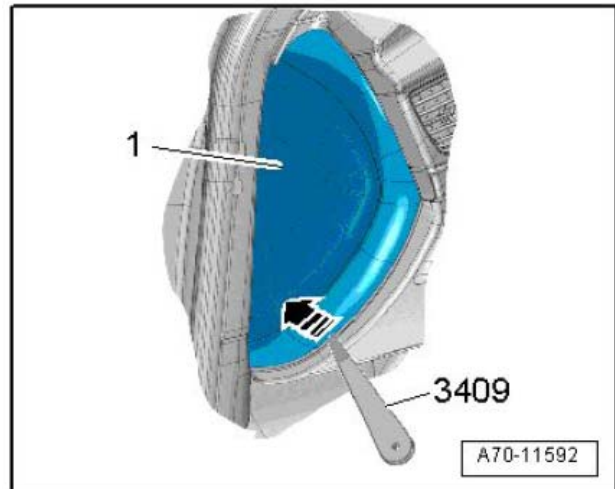

2. On Fuse holder B, fuse carrier ST3 (red) replace fuse 2 with new fuse N 017 131 16 or equivalent.

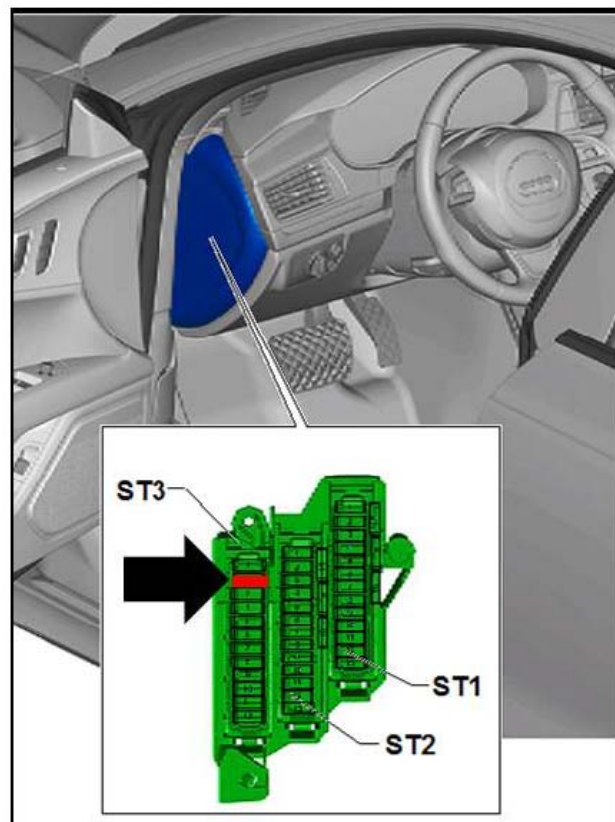

Technical Service Bulletin



Warranty

Update Time Requirements/ Reimbursement	To ensure prompt and proper payment, be sure to immediately enter the applicable reimbursement code listed below upon completion of the repair work. Claims will be paid only for vehicles that show the 97AT code in the Elsa Campaign/Action Information screen on the day of repair.		
97AT Saga Claim Entry Procedure			
Check Elsa to determine whether Update 97AT is open.			
Service No.: 97AT			
Damage Code: 0099			
Parts Manufacturer - Removed part: 002			
Claim Type			
Sold vehicle = 7 10			
Unsold vehicle = 7 90			
Saga Accounting Instructions			
Criteria ID	Repair operation	Labor Operation Number	TU
4G	Replace fuse	9794 5599	10
Criteria ID	Part Number	Part Description	Quantity
4G	N 017 131 16	5A fuse	1.00
There is no reimbursement for vehicle wash or loaner vehicle.			
<u>If the vehicle is outside of the specified warranty period OR if customer refused repairs.</u>			
<u>U.S. dealers:</u> Submit the request through Audi Warranty Online under the <u>Campaigns/Update</u> option.			
<u>Canadian dealers:</u> Fax the Repair Order to Warranty at (905) 428-4811 and provide VIN, applicable Service Number, Customer Information, Dealer Number and Date.			

Additional Actions

Some of the affected vehicles may be involved in additional Actions. Please check your Elsa Campaign/Action Information screen so that any *additional required work can be done simultaneously.*

Technical Service Bulletin



- Verifying Vehicle Eligibility** To verify vehicle eligibility for this Update, *always* check the Elsa Campaign/Action Information screen. The Elsa system is the *only* binding inquiry and verification system; other systems are not valid and *may result in non-payment* of a claim.
- Help for Claim Entry** For questions regarding claim entry, contact Audi Warranty.
- Required Customer Notification** Inform your customer in writing by recording on the Repair Order any and all work that was conducted on the vehicle, including any and all updates completed under this Update.



Required Parts and Tools

Part Number	Part Description	Quantity
N 01713116	5A Fuse	1.00

- Properly destroy and dispose of removed parts in accordance with all state and local requirements, unless otherwise indicated and/or requested through SAGA.
- If you have exhausted your allocated parts and you require additional parts for vehicles affected by this Update but have exceeded your Upper Order Limit, please submit your requests for additional parts via email to upperorderlimits@audi.com. Be sure to include the affected VINs with your order. Prior to submitting your request, ensure that each vehicle has the **97AT** code open in Elsa. Your order will be reviewed and processed accordingly.

Additional Information

All parts and service references provided in this Update are subject to change and/or removal. Always check Elsa for the most current version of this document.