

FLA COE  
FLB COE  
FLD Conventional  
Business Class  
FLC 112 Conventional

Century Class Conventional  
Argosy COE  
Cargo  
Columbia

Coronado  
Business Class M2  
> Cascadia  
108SD/114SD

**Freightliner  
Service Bulletin**

**Description of Revisions:** *This bulletin replaces the version dated April 2014. The bulletin is revised to include the second generation Virtual Technician HU. The first generation ECU is no longer available.*

## General Information

**IMPORTANT:** This bulletin applies to EPA 2010 and later Detroit™ engines DD13, DD15 and DD16.

The Virtual Technician (VT) HU generates diagnostic information to aid the Detroit Diesel Customer Support Center and the technician in diagnosing vehicle fault issues. The system creates sensor log files, captures fault codes, and sends alert messages and other advanced diagnostic information to the Detroit Diesel Customer Support Center. The Virtual Technician utilizes GPS navigation, GSM (cellular telephone) communication, and a J1939 connection for databus monitoring. Virtual Technician does not require any driver input to function. The unit is located behind the sunglass holder on the passenger side of the overhead console, and is mounted to a bracket. See the *Cascadia Troubleshooting Manual* for diagnostic information.

## Parts

See [Table 1](#) for the kit used in this procedure.

Kit		
Kit Number	Description (IMACS)	Description
A06-92490-000	KIT-VIRTUAL, TECH,P3,SLPR CAB	Virtual Technician Kit - Cascadia Sleepercab.
A06-92490-001	KIT-VIRTUAL, TECH,P3,DC,FAIRING	Virtual Technician Kit - Cascadia Daycab with roof fairing or roof deflector.
A06-92490-002	KIT-VIRTUAL, TECH,P3,DC	Virtual Technician Kit - Cascadia Daycab.

**Table 1, Kit**

## Installation Instructions

1. Park the vehicle on a level surface, shut down the engine, and set the parking brake. Chock the rear tires.
2. **Install the power and ground wiring.**
  - 2.1 Disconnect the negative cables from the batteries.
  - 2.2 Remove the instrument cluster, the front switch panel, and the passenger-side lower kick panel. Refer to the *Cascadia Workshop Manual* for instructions.
  - 2.3 Remove the bulkhead connector on the frontwall (engine side).
  - 2.4 Access the ground and ignition splice packs, located behind the front switch panel.
  - 2.5 Remove the ground and ignition splice pack lock and insert the wires from A06-81699-000 as follows.
  - 2.6 Insert the pink wire 81C from the A06-81699-000 harness to the ignition splice pack. Use any available cavity.
  - 2.7 Insert the black ground wire from the A06-81699-000 harness in the ground splice pack. Use any available cavity.
  - 2.8 Route the harness assembly across the dash to the passenger side floor. Secure with cable ties at least every 12 inches.

## Freightliner Service Bulletin

FLA COE  
FLB COE  
FLD Conventional  
Business Class  
FLC 112 Conventional

Century Class Conventional  
Argosy COE  
Cargo  
Columbia

Coronado  
Business Class M2  
> Cascadia  
108SD/114SD

- 2.9 Remove the red connector lock and insert the green wire 433 of the A06-81697-000 harness in cavity 37 (or any available cavity) of the engine side of the bulkhead connector. See [Fig. 1](#).

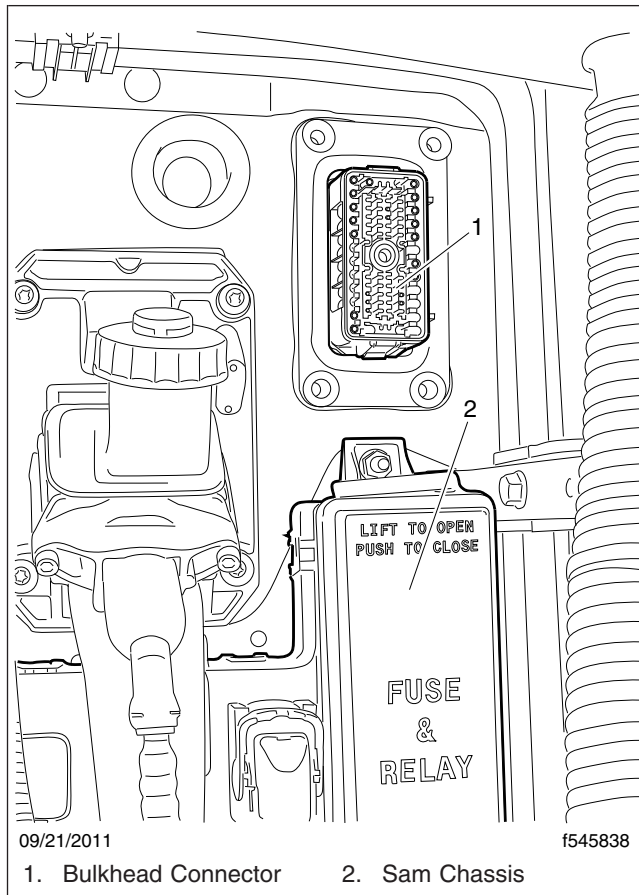

**Fig. 1, Engine-Side Bulkhead Connector**

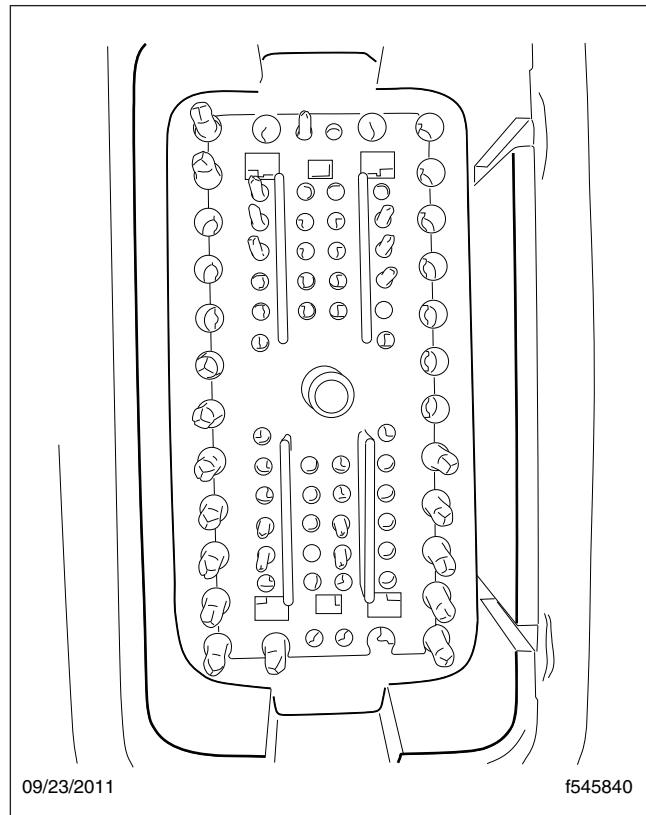

**Fig. 2, Bulkhead Connector**

- 2.10 Remove the red terminal lock and insert the green wire 433 from the A06-81699-000 harness in cavity 37 (or the corresponding cavity from the previous step) of the dash side bulkhead connector.
- 2.11 Place 1/4-inch diameter conduit on the engine side circuit 433 wire and insert the other end from the A06-81697-000 harness in PNDB cavity 3, which is powered by fuse C. See [Fig. 3](#).
- 2.12 Install both sides of the bulkhead connector on the frontwall.
3. **Install the J1939 harness.**
- 3.1 Remove the 120-ohm terminating resistor from the J1939 backbone connector, located behind the passenger-side foot panel on the left side below the HVAC unit. The A06-82488-000 harness comes with a terminating resistor connected.
- 3.2 Connect the female connector from the A06-82488-000 harness to the backbone connector where the 120-ohm terminating resistor was originally removed.
- 3.3 Release the red terminal lock from the 8-pin connector of harness A06-81699-000.

FLA COE  
 FLB COE  
 FLD Conventional  
 Business Class  
 FLC 112 Conventional

Century Class Conventional  
 Argosy COE  
 Cargo  
 Columbia

Coronado  
 Business Class M2  
 > Cascadia  
 108SD/114SD

**Freightliner  
 Service Bulletin**

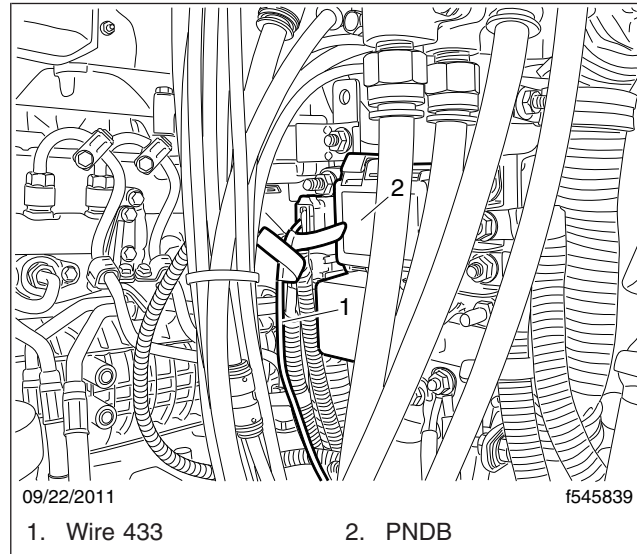

**Fig. 3, Circuit 433 Installation**

- 3.4 Insert one of the J1939 circuit pairs from harness A06-82488-000 into cavities 4 and 5 of the 8-pin connector of harness A06-81699-000 with the yellow wire in cavity 4 and the green wire in cavity 5.
- 3.5 Insert the other J1939 circuit pairs into cavities 6 and 7 of the 8-pin connector of A06-81699-000 with the yellow wire in cavity 7 and the green wire in cavity 6. Push the terminal lock back into the connector.
- 3.6 Release the red terminal lock from the 8-pin connector of harness A06-81700-000.
- 3.7 Insert one of the J1939 circuit pairs from harness A06-82027-000 into cavities 4 and 5 of the 8-pin connector of harness A06-81700-000 with the yellow wire in cavity 4 and the green wire in cavity 5.
- 3.8 Insert the other J1939 circuit pairs into cavities 6 and 7 of the 8-pin connector of A06-81700-000 with the yellow wire in cavity 7 and the green wire in cavity 6. Push the terminal lock back into the connector.
- 3.9 Connect the two 8-pin connectors together and route the A06-81700-000 assembly up the passenger side A pillar and through the overhead console to the location of the passenger side sunglasses holder where the virtual technician module will be installed.
- 3.10 Secure all new wiring with cable ties at approximately 12 inch intervals.

## Freightliner Service Bulletin

FLA COE  
FLB COE  
FLD Conventional  
Business Class  
FLC 112 Conventional

Century Class Conventional  
Argosy COE  
Cargo  
Columbia

Coronado  
Business Class M2  
> Cascadia  
108SD/114SD

### 4. Install the GPS antenna. See [Table 2](#) for instructions based on the vehicle configuration.

GPS Antenna Installation	
Vehicle	Instructions
Sleeper Cabs D06-81829	<ol style="list-style-type: none"> <li>1. Remove the rear passenger side dome lamp.</li> <li>2. Mount the GPS antenna to the top side of the rear passenger-side dome lamp using double-sided tape and two cable ties. See <a href="#">Fig. 4</a>.</li> <li>3. Gently remove the passenger-side auxiliary cargo bezel .</li> <li>4. Route the antenna cable from the dome lamp to the auxiliary cargo bezel, and then to the overhead compartment using fish tape. Headliner removal is not necessary.</li> <li>5. Connect the GPS antenna cable to the GPS antenna.</li> <li>6. Install the dome lamp.</li> </ol>
Daycab with Roof Fairing D06-81830	<ol style="list-style-type: none"> <li>1. Remove the headliner.</li> <li>2. Attach the antenna to the mounting bracket.</li> <li>3. Install the mounting bracket on top of the fairing bracket using the existing fasteners. See <a href="#">Fig. 5</a>.</li> <li>4. Drill a .86-inch (22-mm) hole located just to the lower right of the fairing bracket.</li> <li>5. Run the GPS antenna cable into the cab through the drill hole and secure the rubber grommet pointing over insertion hole.</li> <li>6. Route the GPS antenna cable to the overhead console.</li> </ol>
Daycab, No Roof Fairing	<ol style="list-style-type: none"> <li>1. Remove the headliner.</li> <li>2. Using a step drill bit, drill a 1/2-inch (15-mm) hole in the roof skin at any flat area on the passenger side.</li> <li>3. Remove the nut from the base of the GPS antenna.</li> <li>4. Feed the connector and cable though the hole and secure it down with the nut.</li> <li>5. Connect the antenna pigtail to the antenna cable.</li> <li>6. Install the headliner.</li> </ol>

**Table 2, GPS Antenna Installation**

### 5. Install the Virtual Technician HU.

- 5.1 Record the GPS ID from the label on the back side of the new Virtual Technician HU.
- 5.2 Remove the passenger-side sunglass holder in the overhead console, if it has not already been removed.
- 5.3 Install the VT mounting bracket using four steel U-clips to the vertical plastic struts in the overhead compartment.
- 5.4 Use hook and loop tape to adhere the VT to the mounting bracket.
- 5.5 Connect the 4-pin connector from the A06-81700-000 harness to the VT.
- 5.6 Connect the 10-pin connector from the A06-82027-000 harness to the VT.

FLA COE  
FLB COE  
FLD Conventional  
Business Class  
FLC 112 Conventional

Century Class Conventional  
Argosy COE  
Cargo  
Columbia

Coronado  
Business Class M2  
> Cascadia  
108SD/114SD

**Freightliner  
Service Bulletin**

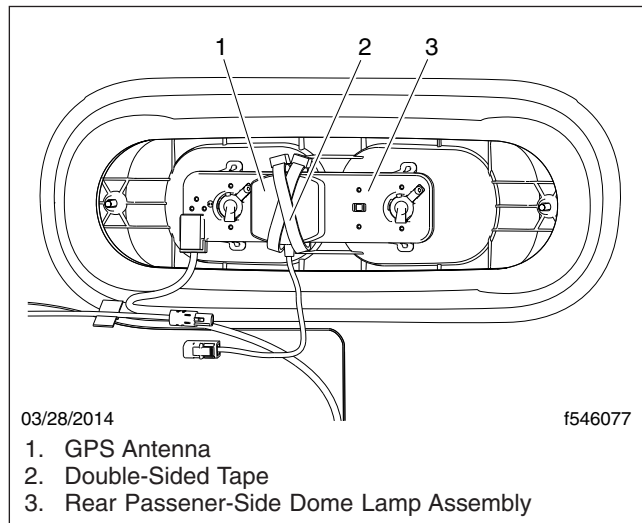

**Fig. 4, GPS Antenna, Installed**

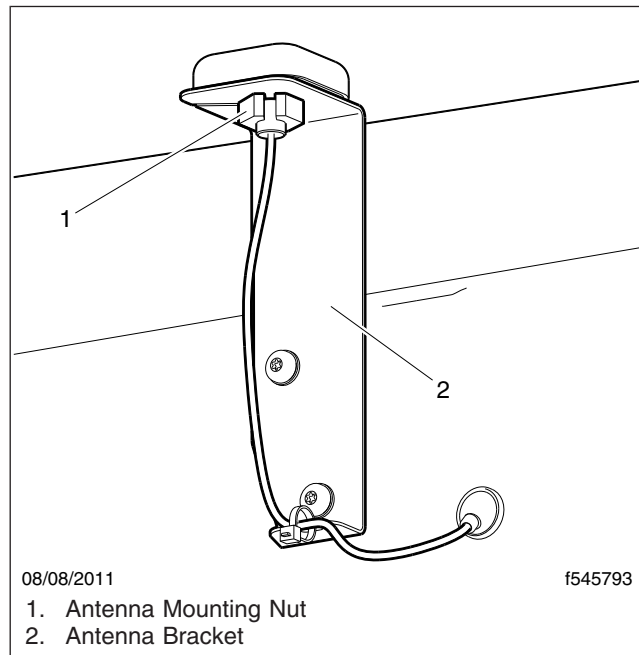

**Fig. 5, External Antenna (daycab)**

5.7 Screw on the GPS antenna cable to the threaded GPS connection.

**NOTE:** If a Qualcomm overhead speaker is present, the following parts are needed (one of each per truck) to move the speaker to the driver-side overhead panel:

- A18-64158-004 for the overhead console driver-side speaker.
- A06-79000-000 for the overhead speaker harness.

## 6. Verify the installation of the Virtual Technician HU.

- 6.1 Connect the batteries.
- 6.2 If no LEDs light up with the ignition ON, diagnose supplied power and ground to the unit. See **Fig. 6** and **Table 3**. There are seven LEDs visible on the VT module. Start the vehicle and drive to an open area, at least 40 feet (12 meters) away from any buildings. Park the vehicle and keep the ignition in the ON position. Apply the parking brake.
- 6.3 Call the *Detroit Customer Support Center*. Make sure to have the vehicle serial number and the Virtual Technician GPS ID number available so that the new VT can be registered.
- 6.4 Install the sunglasses holder in overhead console.
- 6.5 Install the instrument cluster, the CB radio, the front switch panel, and the passenger-side lower kick panel, and any other devices or panels that were removed.

FLA COE  
FLB COE  
FLD Conventional  
Business Class  
FLC 112 Conventional

Century Class Conventional  
Argosy COE  
Cargo  
Columbia

Coronado  
Business Class M2  
> Cascadia  
108SD/114SD

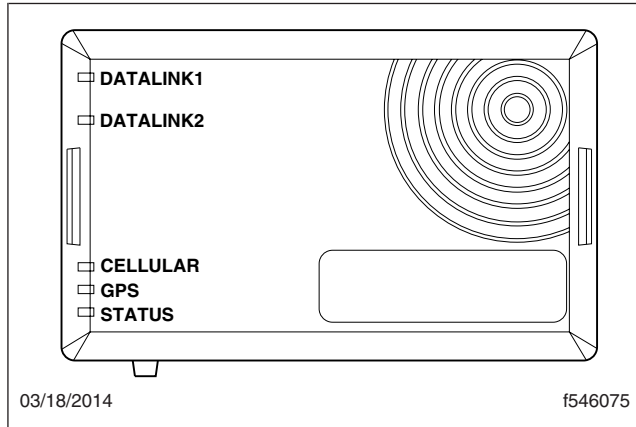

**Fig. 6, Virtual Technician HU LEDs**

Diagnostic LEDs			
Name	Color	Function	Action
DL1	Red	<b>Red Blink (1Hz):</b> J1708 connectivity (disabled). No J1708 activity detected (device is awake). Device is not wired for J1708 connectivity.	Red is the normal and expected state.
DL2	Red and Green	<b>Red Blink (1Hz):</b> J1939 connectivity. No J1939 activity detected (device is awake). <b>Green Blink (1Hz):</b> J1939 activity detected (device is awake) .	Green blink is expected, if LED is blinking red diagnose J1939 connectivity issue at the terminals.
GSM	Green	<b>Solid:</b> GPS connection successful. <b>One Blink:</b> Initializing. <b>Two Blinks:</b> Acquiring time zone information. <b>Three Blinks:</b> Attempting to make a GPS connection.	Solid is expected – if otherwise call the Customer Support Center for further instruction.  NOTE: The VT must be in a 2G network service area.
GPS	Green	<b>Solid:</b> Satellites acquired. <b>One Blink:</b> Acquiring satellites.	Refer to J1939 Fault codes if a problem is suspected.

FLA COE  
 FLB COE  
 FLD Conventional  
 Business Class  
 FLC 112 Conventional

Century Class Conventional  
 Argosy COE  
 Cargo  
 Columbia

Coronado  
 Business Class M2  
 > Cascadia  
 108SD/114SD

**Freightliner  
 Service Bulletin**

Diagnostic LEDs			
Name	Color	Function	Action
Status	Green	<b>Solid:</b> Engine running. <b>One Blink:</b> Engine not running; no data to send. <b>Two Blinks:</b> Data is available to be sent. <b>Four Blinks:</b> GPS storage log is full.	Refer to J1939 Fault codes if a problem is suspected.
AUX	Red	<b>Solid:</b> GSM Modem Comm. Error, or panic line is active. <b>Two Blinks:</b> Not Used. <b>Three Blinks:</b> GSM modem is not starting up. <b>Four Blinks:</b> SIM Card read error. <b>Five Blinks:</b> GSM CTS (clear-to-send) line is active.	Refer to J1939 Fault codes if a problem is suspected.
Tamper	Red	Disabled	N/A

**Table 3, Diagnostic LEDs**

## Warranty

This is an informational bulletin only. Warranty does not apply.