

> Constellation  
Heritage  
> 4700 Models

> 4800 Models  
> 4900 Models

5900 Models  
> 6900 Models

Western Star  
Service Bulletin

**Description of Revisions:** *This bulletin replaces the version dated July 2013. The bulletin is revised to include the second generation Virtual Technician HU. The first generation ECU is no longer available.*

## General Information

The Virtual Technician (VT) HU generates diagnostic information to aid the *Detroit™ Customer Support Center* and the technician in diagnosing complex engine control issues. The system creates sensor log files, captures fault codes, and sends alert messages and other advanced diagnostic information to the *Detroit Customer Support Center*. The VT utilizes GPS navigation, GSM (cellular telephone) communication, and a J1939 connection for databus monitoring. Virtual Technician does not require any driver input to function. The VT is located behind the dash, next to the passenger-side glove box.

## Parts

See [Table 1](#) for the kit used in this procedure.

Kit Number	Description (IMACS)	Kit	
		Description	
A06-92493-000	KIT-VIRTUAL TECH,WST,STAR,PRE-VT	Virtual Technician Kit - Daycab and Starlight Sleepercab, built before June 6, 2011.	
A06-92493-001	KIT-VIRTUAL TECH,WST,STAR,POST-VT	Virtual Technician Kit - Daycab and Starlight Sleepercab, built after June 6, 2011.	
A06-92493-002	KIT-VIRTUAL TECH,WST,STRATPRE,VT	Virtual Technician Kit - Stratosphere Sleepercab, built before June 6, 2011.	
A06-92493-003	KIT-VIRTUAL TECH,WST,STRAT,POST-VT	Virtual Technician Kit - Stratosphere Sleepercab, built after June 6, 2011.	
A06-92493-004	KIT-VIRTUAL TECH,WST,ZODIAC	Virtual Technician Kit - 4700.	
A06-92493-005	KIT-VIRTUAL TECH,WST,STARLT	Virtual Technician Kit - Starlight.	
A06-92493-006	KIT-VIRTUAL TECH,WST,STRATOS	Virtual Technician Kit - Stratosphere.	

Table 1, Kit

## Installation Instructions

1. Park the vehicle on a level surface, shut down the engine, and set the parking brake. Chock the rear tires.
2. **Install the power and ground wiring. Refer to wiring diagram G06-82895.**
  - 2.1 Disconnect the negative cables from the batteries.
  - 2.2 Remove the instrument cluster, the CB radio, and any other devices or panels necessary for harness routing. Refer to the *Western Star Workshop Manual* for instructions.
  - 2.3 Access the ground and ignition splice packs, located behind the center dash panel. See [Fig. 1](#).
  - 2.4 Remove the ground and ignition splice pack lock and insert the wires from the A06-82896-000 harness (A06-83364-000 for the 4700).
  - 2.5 Insert the pink wire 81C from the A06-82896-000 harness (A06-83364-000 for the 4700) to the ignition splice pack. Use any available cavity.

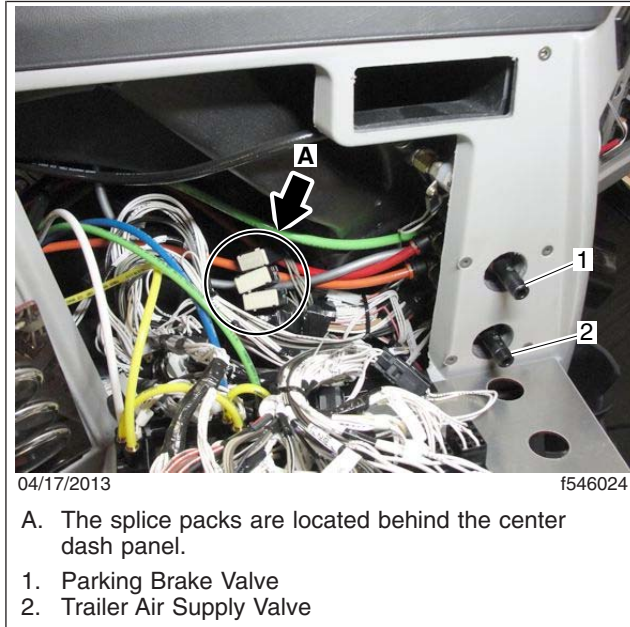

**Fig. 1, Western Star Dash Assembly**

- 2.6 Insert the black ground wire from the A06-82896-000 harness (A06-83364-000 for the 4700) in the ground splice pack. Use any available cavity.
- 2.7 Route the green power wire 433 on the A06-82896-000 harness (A06-83364-000 for the 4700) behind the dash to the bulkhead connector.
- 2.8 Remove the bulkhead connector, above the airlines, on the frontwall (engine side).
- 2.9 Remove the terminal locks and insert the green wire 433 from the A06-82896-000 harness (A06-83364-000 for the 4700) in cavity 27 of the dash side of the bulkhead connector.
- 2.10 Insert the green wire 433 of the A06-82897-000 harness (A06-83365-000 for the 4700) in cavity 27 of the engine side of the bulkhead connector.

**IMPORTANT:** Vehicles with an EPA07 or EPA10 engine have a 40-pin bulkhead connector. All 4700 vehicles and vehicles with an EPA13 engine have a 76-pin bulkhead connector.

- 2.11 Insert the other end of green wire 433 from the A06-82897-000 harness (A06-83365-000 for the 4700) in powernet distribution box (PNDB) cavity 3. See [Fig. 2](#).
- 2.12 Insert the terminal lock into the bulkhead connector, then connect the dash and engine side of the connector. See [Fig. 3](#).

### 3. Install the J1939 harness.

**NOTE:** On 4800, 4900, and 6900 model vehicles built *after* June 6, 2011, the J1939 10-pin connector is installed in production next to the Virtual Technician HU. A J1939 jumper harness is not required. If the vehicle is in this group, continue with step 4.

On 4800, 4900, and 6900 models built *before* June 6, 2011, and all 4700 models, a J1939 jumper harness (A06-87079-xxx) must be installed. The location of the terminating resistor depends on the vehicle model:

> Constellation  
Heritage  
> 4700 Models

> 4800 Models  
> 4900 Models

5900 Models  
> 6900 Models

**Western Star  
Service Bulletin**

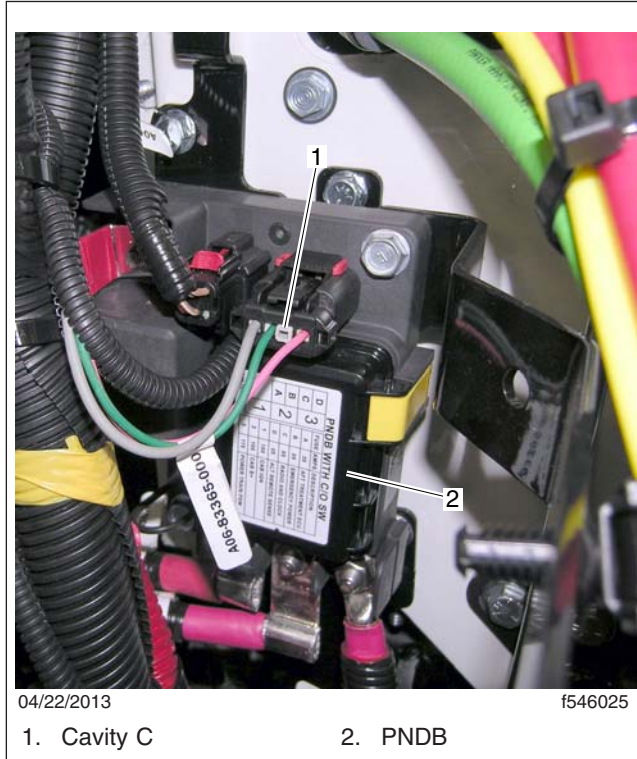

**Fig. 2, PNDB on the Frontwall**

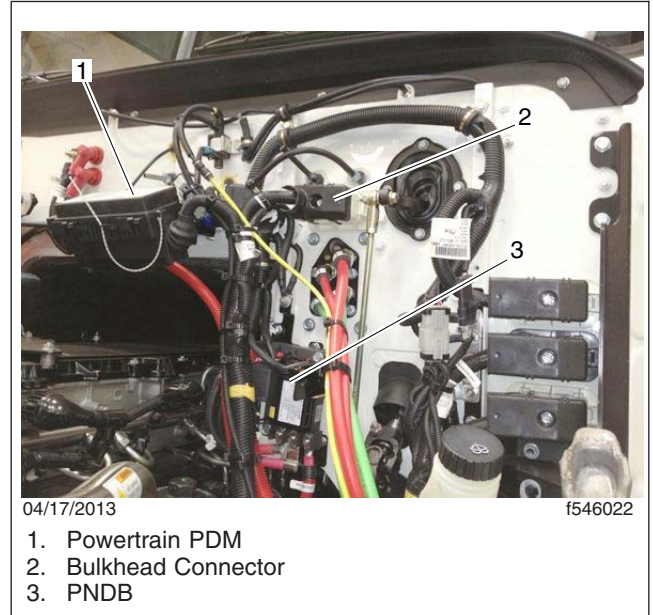

**Fig. 3, Bulkhead Connector on the Engine Side of the Frontwall**

- On 4800, 4900, and 6900 models, the terminating resistor is located behind the driver-side instrument panel. See [Fig. 4](#).
- On 4700 models, the terminating resistor is located behind the glove box. See [Fig. 5](#).

- 3.1 Remove the 120-ohm terminating resistor from the J1939 backbone connector, located behind the instrument panel.
- 3.2 Install the 120-ohm terminating resistor to the 2-pin male connector on the A06-87079-108 harness for 4800, 4900, 6900 model vehicles, and A06-87079-008 for 4700 model vehicles.
- 3.3 Connect the 2-pin female connector from the A06-87079-108 harness for 4800, 4900, 6900 model vehicles, and A06-87079-008 for 4700 model vehicles to the backbone connector where the 120-ohm terminating resistor was originally removed.

**NOTE:** The Virtual Technician HU 4-pin connector on the A06-82896-000 harness (A06-83364-000 for 4700), and the Virtual Technician HU 10-pin connector on the A06-87079-108 harness (on 4800, 4900, 6900 model vehicles built prior to June 6, 2011), are both routed from below the dash to the VT HU located behind the passenger side glove box. On the 4800, 4900, and 6900 model vehicles built after June 6, 2011, the VT HU 10-pin connector is routed from behind the glove box to the VT HU.

4. **Install the GPS antenna.** See [Table 2](#) for instructions based on the vehicle configuration.

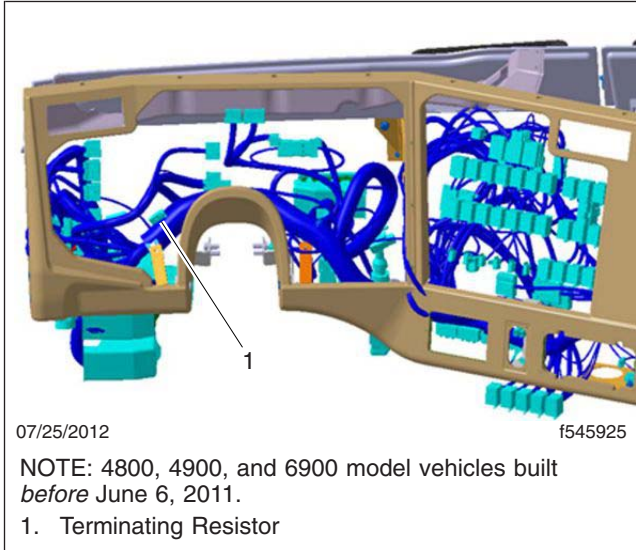

**Fig. 4, Terminating Resistor Located Behind the Driver-Side Instrument Panel**

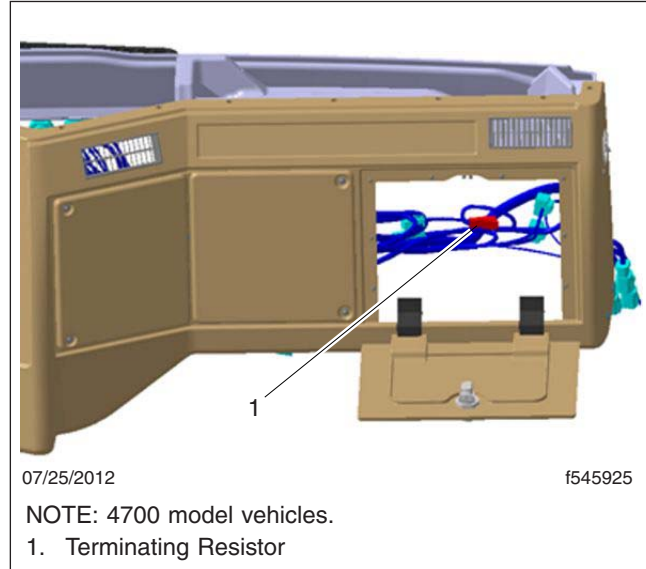

**Fig. 5, Terminating Resistor Located Behind the Glove Box**

GPS Antenna Installation	
Vehicle	Instructions
Stratosphere Sleepercab D06-83004-001	<ol style="list-style-type: none"> <li>1. Remove the passenger side sunglass holder in the overhead console.</li> <li>2. Remove the adhesive backing from antenna and adhere to the top of the passenger-side overhead console. See <a href="#">Fig. 6</a>.</li> <li>3. Connect the antenna pigtail connector to the antenna cable.</li> <li>4. Route the antenna cable down the A-pillar to the VT HU behind the passenger side glove box.</li> <li>5. Install the sunglass holder.</li> </ol>

> Constellation  
Heritage  
> 4700 Models

> 4800 Models  
> 4900 Models

5900 Models  
> 6900 Models

**Western Star  
Service Bulletin**

GPS Antenna Installation	
Vehicle	Instructions
Daycab and Starlight Seepercab D06-83004-000	<ol style="list-style-type: none"> <li>1. Remove the headliner.</li> <li>2. Using a step drill bit, drill a .60-inch (15-mm) hole in the roof skin at any flat area on the passenger side.</li> <li>3. Cut the rubber grommet off the GPS antenna pigtail connector.</li> <li>4. Remove the nut from the base of the GPS Antenna.</li> <li>5. Feed the connector and cable through the hole and secure it down with the nut. Apply a thin layer of Loctite 595 clear silicone weather sealant (or equivalent) to the foam pad on the base of the antenna. See <a href="#">Fig. 7</a>.</li> <li>6. Connect the antenna pigtail connector to the antenna cable.</li> <li>7. Route the antenna cable from down the A-pillar to the VT HU behind the passenger side glove box. See <a href="#">Fig. 8</a>.</li> <li>8. Install the headliner.</li> </ol>

**Table 2, GPS Antenna Installation**

## 5. Install the Virtual Technician HU.

5.1 Record the GPS ID, VIN, and ESN from the label on the back side of the new Virtual Technician HU.

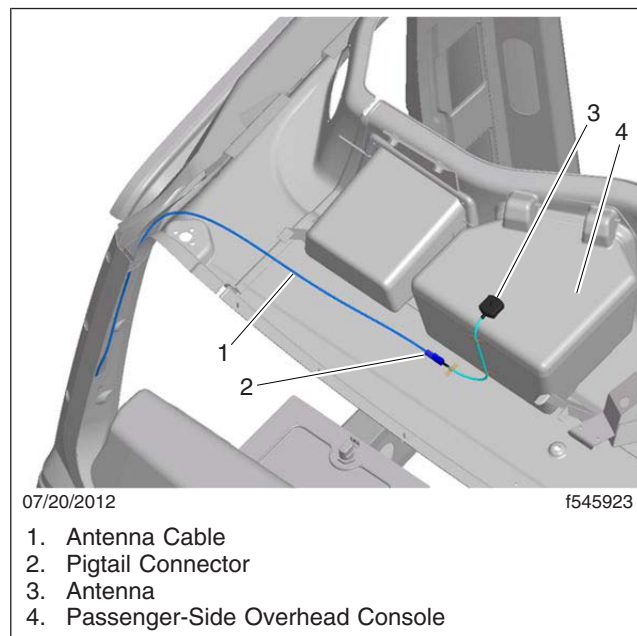
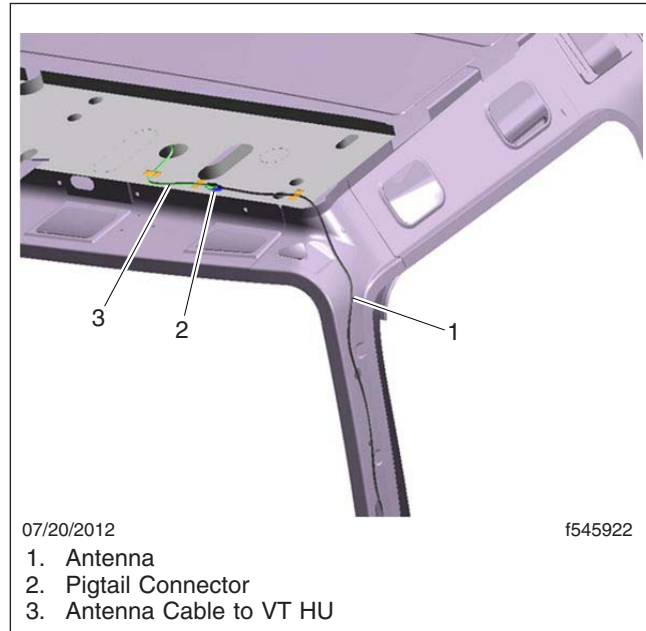

**Fig. 6, Antenna Routing Stratosphere**

5.2 Remove the passenger side glove box.



**Fig. 7, Antenna Location, Daycab and Starlight Sleepercab**



**Fig. 8, Antenna Routing, Daycab and Starlight Sleepercab**

- 5.3 Install the VT HU mounting bracket 06-82953-000, using four 6 x 5/16 screws, between the glove box and the inside dash wall. See A18-52930, page 2, View A.
- 5.4 Snap the VT HU into the mounting bracket.
- 5.5 Connect the 4-pin connector from the A06-82896-000 (A06-83364-000 for the 4700) to the VT. See [Fig. 9](#).
- 5.6 Connect the VT HU 10-pin connector from the A06-87079-008 harness (4700 model vehicles), A06-87079-108 harness (4800, 4900, 6900 model vehicles built prior to June 6, 2011), or factory-installed dash harness (4800, 4900, 6900 model vehicles built after June 6, 2011) to the VT.
- 5.7 Screw on the GPS antenna cable to the threaded GPS label connection.
6. **Verify the installation of the Virtual Technician HU.**
  - 6.1 Connect the batteries.
  - 6.2 If no LEDs light up with the ignition ON, diagnose supplied power and ground to the unit. See [Fig. 10](#) and [Table 3](#). There are seven LEDs visible on the VT module. Start the vehicle and drive to an open area, at least 40 feet (12 meters) away from any buildings. Park the vehicle and keep the ignition in the ON position. Apply the parking brake.
  - 6.3 Call the *Detroit Customer Support Center*. Make sure to have the vehicle serial number and the Virtual Technician GPS ID number available so that the new VT can be registered.
  - 6.4 Install the passenger-side glove box.
  - 6.5 Install the instrument cluster, the CB radio, the front switch panel, and the passenger-side lower kick panel, and any other devices or panels that were removed.

> Constellation  
Heritage  
> 4700 Models

> 4800 Models  
> 4900 Models

5900 Models  
> 6900 Models

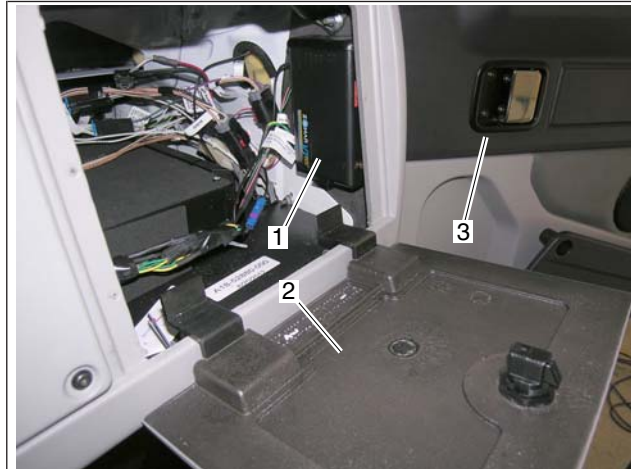

04/17/2013

f546023

1. Virtual Technician HU
2. Glove Box Door (open)
3. Passenger-Side Door

**Fig. 9, Virtual Technician HU, Installed**

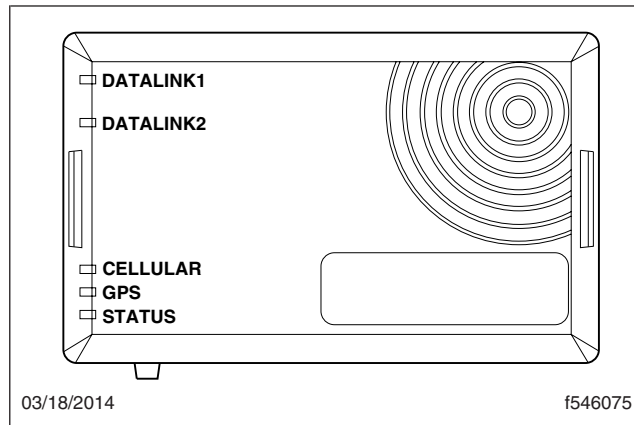

03/18/2014

f546075

**Fig. 10, Virtual Technician HU LEDs**

Diagnostic LEDs			
Name	Color	Function	Action
DL1	Red	<b>Red Blink (1Hz):</b> J1708 connectivity (disabled). No J1708 activity detected (device is awake). Device is not wired for J1708 connectivity.	Red is the normal and expected state.

Diagnostic LEDs			
Name	Color	Function	Action
DL2	Red and Green	<p><b>Red Blink (1Hz):</b> J1939 connectivity. No J1939 activity detected (device is awake).</p> <p><b>Green Blink (1Hz):</b> J1939 activity detected (device is awake) .</p>	Green blink is expected, if LED is blinking red diagnose J1939 connectivity issue at the terminals.
GSM	Green	<p><b>Solid:</b> GPS connection successful.</p> <p><b>One Blink:</b> Initializing.</p> <p><b>Two Blinks:</b> Acquiring time zone information.</p> <p><b>Three Blinks:</b> Attempting to make a GPS connection.</p>	<p>Solid is expected – if otherwise call the Customer Support Center for further instruction.</p> <p>NOTE: The VT must be in a 2G network service area.</p>
GPS	Green	<p><b>Solid:</b> Satellites acquired.</p> <p><b>One Blink:</b> Acquiring satellites.</p>	Refer to J1939 Fault codes if a problem is suspected.
Status	Green	<p><b>Solid:</b> Engine running.</p> <p><b>One Blink:</b> Engine not running; no data to send.</p> <p><b>Two Blinks:</b> Data is available to be sent.</p> <p><b>Four Blinks:</b> GPS storage log is full.</p>	Refer to J1939 Fault codes if a problem is suspected.
AUX	Red	<p><b>Solid:</b> GSM Modem Comm. Error, or panic line is active.</p> <p><b>Two Blinks:</b> Not Used.</p> <p><b>Three Blinks:</b> GSM modem is not starting up.</p> <p><b>Four Blinks:</b> SIM Card read error.</p> <p><b>Five Blinks:</b> GSM CTS (clear-to-send) line is active.</p>	Refer to J1939 Fault codes if a problem is suspected.
Tamper	Red	Disabled	N/A

**Table 3, Diagnostic LEDs**

## Warranty

This is an informational bulletin only. Warranty does not apply.