

1 10 05-14



Service Information Bulletin

SUBJECT	DATE
Oil Coolant Module	October 2014

Additions, Revisions, or Updates

Publication Number / Title	Platform	Section Title	Change
DDC-SVC-MAN-0081 DDC-SVC-MAN-0181 DDC-SVC-MAN-S181	DD Platform EuroIV	Removal of the Oil Coolant Module Installation of the Oil Coolant Module	Altered steps for better serviceability.



13400 Outer Drive, West, Detroit, Michigan 48239-4001
 Telephone: 313-592-5000
www.demanddetroit.com

2 Removal of the Oil Coolant Module

Remove as follows:

1. Shut off the engine, apply the parking brake, chock the wheels, and perform any other applicable safety steps.
2. Open hood.
3. Disconnect the batteries. Refer to the OEM procedure.
4. Loosen oil filter cap to allow oil to drain to the pan.
5. If necessary, remove the front bumper. Refer to the OEM procedure.
6. Drain the coolant. Refer to section "Cooling System Drain Procedure".
7. Remove the plug (1) on the bottom of the oil coolant module. Discard O-ring (2).

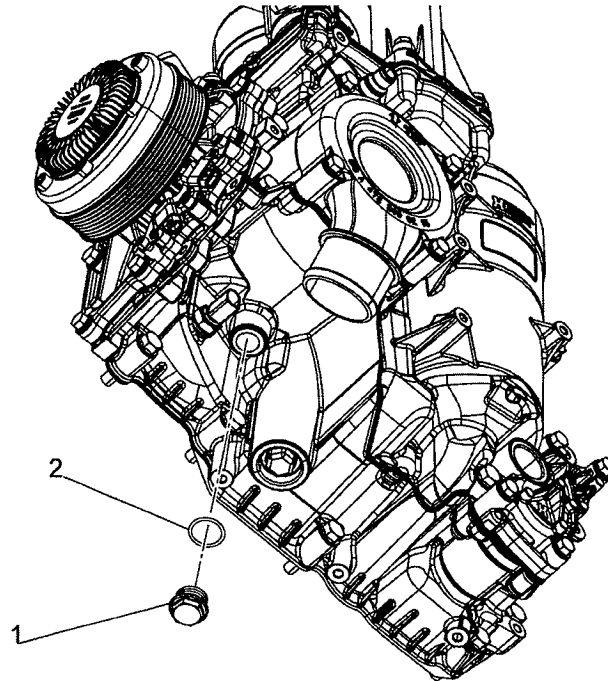

d200074

8. Remove the thermostat. Refer to section "Removal of the Engine Coolant Thermostat and Seal".
9. Remove engine harness connectors from the coolant temperature sensor, intake air temperature sensor, and throttle valve. Cut the ties securing the harness to the oil coolant module.

NOTE: Ensure any remaining coolant is drained from the oil coolant module and from the cylinder block to prevent coolant from contaminating the engine oil.

10. Remove the coolant crossover pipe. Refer to section "Removal of the Coolant Crossover Pipe".
11. Remove the mixer pipe, cold boost pipe and throttle valve as an assembly. Refer to section "Removal of the Intake Throttle/EGR Mixer Assembly".
12. Loosen the clips and remove the heater, coolant recovery, and Exhaust Gas Recirculation (EGR) coolant supply hoses from oil coolant module.
13. If equipped, inspect the coolant coupler hose for damage. Discard if damage is found.
14. If necessary, remove the air filter housing. Refer to the OEM procedure.
15. Disconnect the coolant line from the fuel module to the oil coolant module.
16. Remove the poly-V-belt from the water pump pulley. Refer to section "Removal of the Poly-V-Belts".
17. Remove the radiator support rod and bracket.
18. Remove the oil dipstick tube by removing the two bolts and bracket attaching it to the cylinder block.
19. If equipped, disconnect the block heater and cut remaining harness ties.

20. If equipped, remove the harness bracket from near the bottom of the oil coolant module.
21. Remove eleven bolts securing oil coolant module to engine block and remove oil coolant module.

NOTICE: No abrasive power tools or abrasive pads should be used on the block or module gasket surfaces. Debris created using abrasives may enter the oil system and cause severe engine damage.

22. Inspect the mounting surface on the cylinder block for any foreign debris or remaining gasket material; wipe clean using a shop towel. Sealing surfaces should be clean and dry.

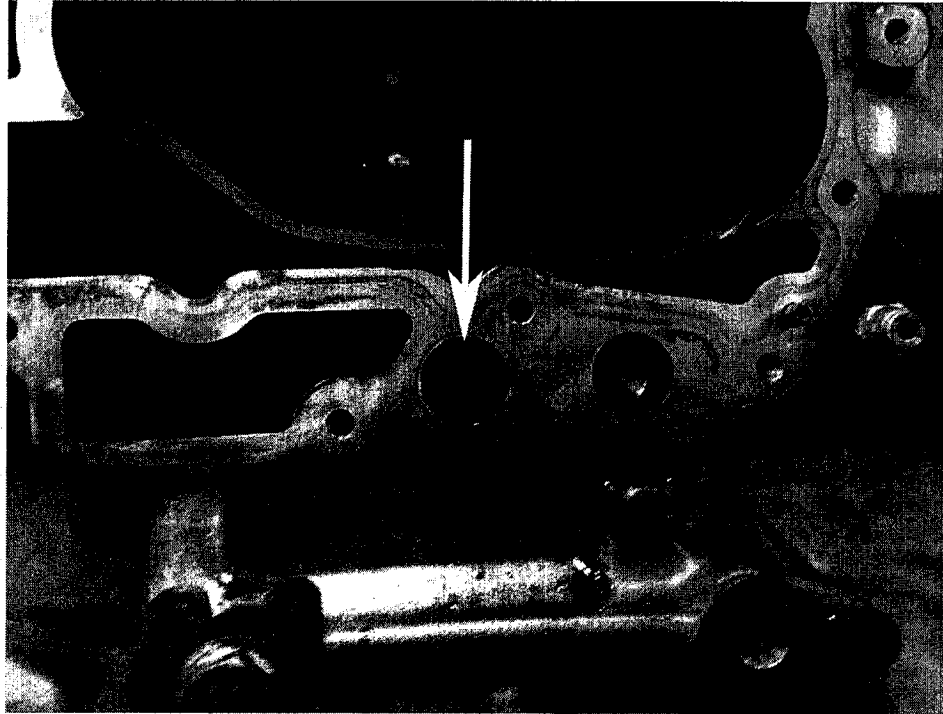

d180045

23. Remove and discard the gasket.
24. Using a new O-ring, install the plug on the bottom of the oil coolant module. Torque to 50 N·m (37 lb·ft).

3 Installation of the Oil Coolant Module

Install as follows:

NOTICE: No abrasive power tools or abrasive pads should be used on the block or module gasket surfaces. Debris created from using abrasives may enter the oil system and cause severe engine damage.

1. Inspect the mounting surface on the cylinder block for any foreign debris or remaining gasket material; wipe clean using a shop towel. Sealing surfaces should be clean and dry.

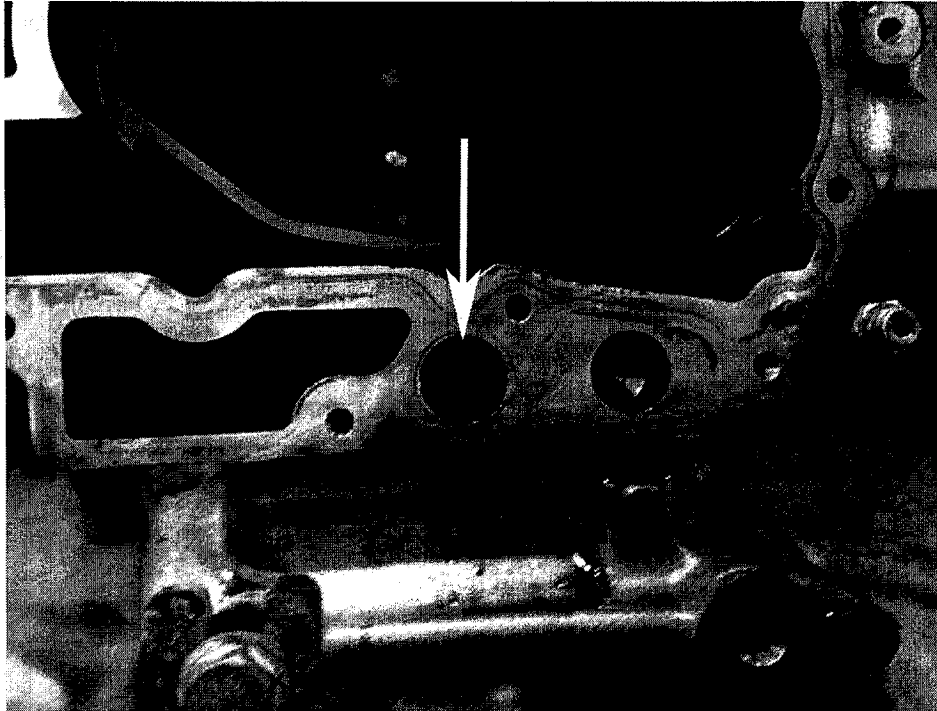

d180045

2. Install new gasket onto guide pins on the cylinder block.
3. Install the oil coolant module onto the guide pins on the cylinder block. Install eleven bolts.
4. Torque the bolts to the following specifications using the torque sequence below:
 - a. 10 N·m (7 lb·ft).
 - b. Final torque the bolts to 60 to 65 N·m (44 to 48 lb·ft).

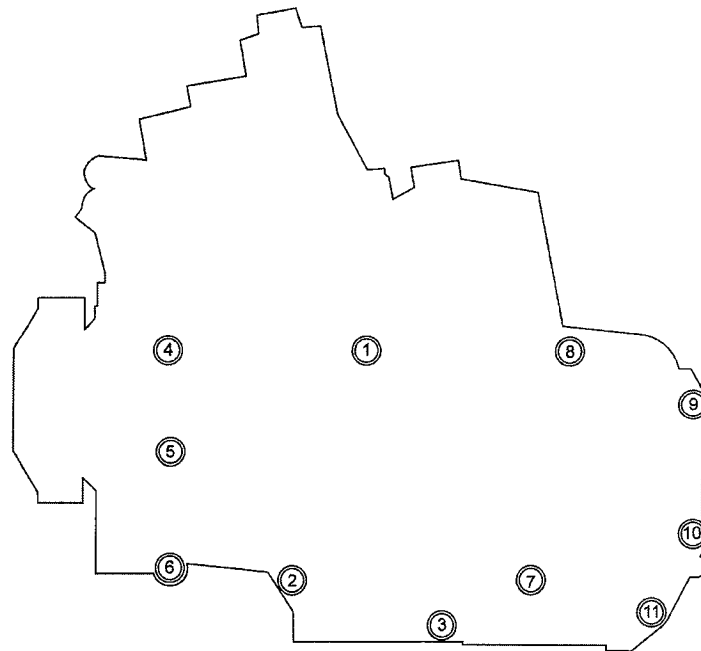

d180041

5. If equipped, install the block heater and harness tie straps.
6. If removed, install the water pump.
 - a. For a standard water pump, Refer to section "Installation of the Water Pump".
 - b. For a variable speed water pump, Refer to section "Installation of the Variable Speed Water Pump".
7. Install the radiator support rod and bracket. Torque to 100 N·m (74 lb·ft).
8. Install the Poly-V-belt to the water pump pulley. Refer to section "Installation of the Poly-V-Belts".
9. Connect coolant line to fuel module and oil coolant module.
10. If equipped, install heater hose to oil coolant module.

NOTE: Before installing the coolant crossover pipe, check the coupler hose for damage. Replace as necessary.

11. Install the coolant crossover pipe. Refer to section "Installation of the Coolant Crossover Pipe".
12. If removed, install the air filter housing. Refer to the OEM procedure.
13. Install the mixer pipe, cold boost pipe and throttle valve as an assembly. Refer to section "Installation of the Intake Throttle/EGR Mixer Assembly".
14. Install the thermostat to the oil coolant module with four bolts. Torque to 20 to 25 N·m (15 to 19 lb·ft).
15. If removed, install the dipstick tube and two bolts and torque to 15 N·m (11 lb·ft).
16. If removed, install the front bumper. Torque bolts to 27 N·m (20 lb·ft).
17. Torque the oil filter cap to 40 to 50 N·m (30 to 37 lb·ft).
18. Connect the batteries. Refer to the OEM procedure.
19. Tighten radiator drain fitting (refer to OEM for proper torque specifications).
20. Fill the coolant system. Refer to section "Cooling System Fill Procedure".



WARNING: ENGINE EXHAUST

To avoid injury from inhaling engine exhaust, always operate the engine in a well-ventilated area. Engine exhaust is toxic.



WARNING: PERSONAL INJURY

To avoid injury before starting and running the engine, ensure the vehicle is parked on a level surface, parking brake is set, and the wheels are blocked.

21. Start the engine and inspect for leaks.
22. Verify proper coolant level.
23. Close hood.