



The Audi 1.8L and 2.0L Third Generation EA888 Engines

Audi of America, LLC
Service Training
Created in the U.S.A.
Created 11/2013
Course Number 920243

©2013 Audi of America, LLC

All rights reserved. Information contained in this manual is based on the latest information available at the time of printing and is subject to the copyright and other intellectual property rights of Audi of America, LLC., its affiliated companies and its licensors. All rights are reserved to make changes at any time without notice. No part of this document may be reproduced, stored in a retrieval system, or transmitted in any form or by any means, electronic, mechanical, photocopying, recording or otherwise, nor may these materials be modified or reposted to other sites without the prior expressed written permission of the publisher.

All requests for permission to copy and redistribute information should be referred to Audi of America, LLC.

Always check Technical Bulletins and the latest electronic service repair literature for information that may supersede any information included in this booklet.

Introduction	5
Development goals	6
Brief technical description	7
Technical features	8
Engine mechanicals	10
Overview	10
Cylinder block	10
Oil pan	11
Crankshaft assembly	12
Chain drive	14
Balance shafts	15
Auxiliaries mounting bracket	16
Cylinder head	18
Integral exhaust manifold	21
Positive crankcase ventilation	23
Oil supply.....	28
System overview	28
Oil supply	30
Oil filler cap	32
Switchable piston cooling jets	32
Cooling system.....	34
System overview	34
Innovative Thermal Management (ITM)	36
Air supply and charging	49
System overview	49
Air routing system for transversely mounted engines	50
Air routing system for longitudinal mounted engines	51
Intake manifold	52
Turbocharger	53
Fuel system	57
System overview	57
Mixture formation / dual injection system	58
Operating modes	59
Engine management system	62
System overview example – 1.8l TFSI engine	62
Differences between 1.8L longitudinally and transversely mounted engines	64
Differences between components in the engines with 1.8 l and 2.0 l displacement	65
Component differences for the 2015 Audi S3	66
Differences between the exhaust turbochargers	67
Differences between combustion methods	68
Special tools	69
Self Study Programs.....	70
Knowledge Assessment	71

eMedia



This eSSP contains video links which you can use to access interactive media.

This eSelf Study Program teaches a basic knowledge of the design and functions of new models, new automotive components or technologies.

It is not a Repair Manual!

All values given are intended as a guideline only.

For maintenance and repair work, always refer to the current technical literature.



Note



Reference

The launch of the new 1.8L and 2.0L TFSI engines marks the beginning for the third generation of the successful EA888 four cylinder engine family from Audi. The motives for this development are increasingly stringent exhaust emission standards, better fuel economy and reduced CO₂ emissions. To achieve these goals, the engines have been completely revised.

This “global engine” is manufactured at Audi’s Hungarian plant in Győr; in Silao, Mexico; Shanghai and Dalian China. In the future it will also be produced in Changchun. Like the second generation versions of this engine, it is available in both 1.8L and 2.0L displacements. It is used for a variety of vehicle platforms and Group brands and is available in a wide range of power ratings.

Another design requirement was that the engines be suitable for use in all markets, including those where low grade fuel is prevalent.

Please note:

Some illustrations of the 1.8L engine in this eSelf-Study Program are for the world-wide market. With the North American introduction of the third generation EA888 engines, the 1.8L engine will not have a continuously adjustable exhaust camshaft nor AVS.

Learning objectives of this eSelf Study Program:

This eSelf-Study Program introduces you to the technology of the third generation of EA888 4 cylinder engines. Upon completing this eSelf-Study Program, you will be able to answer the following questions:

- ▶ What are the key technical modifications behind the development of the EA888 engine family?
- ▶ How do the innovative, new technologies work?
- ▶ What changes do the 1.8L and 2.0L engines bring to customer service?



606_001



Reference

For a detailed technical description of the first generation engine, please refer to eSelf-Study Program 921703, *The Audi 2.0 Liter Chain-driven TFSI Engine*.



Reference

To find more about the modifications to the first and second generation engines, please refer to eSelf-Study Program 922903, *The 2.0L 4V TFSI Engine with AVS*.

Development goals

The main goals for developing the third generation of the EA888 engine family were to meet more stringent exhaust emission standards and provide compatibility of the engine with various modular platforms.

The engineers in Ingolstadt placed special emphasis on the following priorities during the development cycle:

- ▶ A high proportion of identical parts for all engine versions
- ▶ Reducing engine weight
- ▶ Minimizing intra-engine friction
- ▶ Increasing power output and torque in conjunction with good fuel economy

Modular adaptation

To use the third generation of the EA888 engine family as a "global engine" in the modular longitudinal application (MLB) and the modular transverse application (MQB), it was necessary to revise its dimensions, mounting and connecting points.

CO₂ reduction

To meet emission limits while reducing CO₂ output, the following design modifications have been made:

Downsizing/downspeeding*

Friction and weight reduction

- ▶ Balance shafts partially mounted in needle bearings
- ▶ Smaller main crankshaft bearing diameter
- ▶ Lower oil level
- ▶ Reduced tensioning force in the auxiliary drive

Reducing friction

The chain tensioners have been optimized for the reduced oil pressure. In addition to this, the tensioning force of the chains has been reduced, in turn reducing friction. Also, the crankshafts are made with smaller main bearing diameters which produce less friction.

The following innovative, new technologies are featured:

- ▶ Exhaust manifold integrated into the cylinder head
- ▶ Dual injection system with direct and port injection**
- ▶ New, compact turbocharger module with cast steel turbine housing, electrical wastegate actuator and oxygen sensor upstream of the turbine
- ▶ Innovative Thermal Management system with fully electronic coolant temperature control

Engine mounts and a dipstick are used if the engine is transversely mounted. If the engine is longitudinally mounted, use is made of engine supports and a sealing cap in place of a dipstick.

Cylinder head

- ▶ Cylinder head with Integrated Exhaust Manifold (IEM)
- ▶ Weight-reduced exhaust turbocharger housing
- ▶ Electrical wastegate actuator

Injection

- ▶ FSI and MPI fuel injectors**

Thermal management

- ▶ Rotary slide valve control

The poly-Vee belt drive configuration is identical for longitudinal and transverse mounted engines. However, the alternators and A/C compressors are model-dependent.

* The term downspeeding is used to describe the reduction in engine speed achieved by altering the overall transmission ratio. Use of a drive ratio optimized for fuel efficiency makes it possible to achieve reductions in fuel consumption similar to those achievable by reducing engine displacement. The higher power output and average pressure level of turbocharged engines allows the operating point to be shifted towards lower engine speeds and higher engine loads. This means that the engine can be operated in an rpm range that is more favorable in terms of fuel economy. Downspeeding concepts generally go hand in hand with downsizing concepts - a combination particularly well suited to turbocharged direct injection gasoline engines.

** The initial offering of the 3rd generation engine in the North American market will be equipped only with FSI. The dual injection system with both MPI and FSI will be introduced in later models.

Brief technical description

Engine type

- ▶ Four-cylinder in-line gasoline engine with direct injection and MPI*
- ▶ Exhaust turbocharging with charge air cooling
- ▶ Chain driven camshafts
- ▶ Balance shafts - partially supported by needle bearings

Valve control

- ▶ Four valves per cylinder, double overhead camshafts
- ▶ Continuous intake and exhaust camshaft adjustment on the 2.0L engine
- ▶ Continuous intake camshaft adjustment on the 1.8L engine
- ▶ Audi valvelift system (only on the exhaust camshaft of 2.0L version in the North American market)

Engine Management

- ▶ Electronic engine management system with EPC
- ▶ Combined direct and port injection systems*
- ▶ Adaptive O₂ sensor control
- ▶ Mapped ignition with high voltage ignition coils
- ▶ Cylinder-selective adaptive knock control

* The initial offering of the 3rd generation engine in the North American market will be equipped only with FSI. The dual injection system with both MPI and FSI may be introduced in later models.

eMedia



Animation showing the overall engine.



606_057

Technical features

1.8L TFSI engine

Engine code	CNSB
Installation position	transverse
Displacement cu in (cm ³)	109.7 (1798)
Power output at rpm	170 hp at 5100 - 6200 (125 kW at 5100 - 6200)
Torque at rpm	184 lb ft at 1250 - 5000 (250 Nm at 1250 - 5000)
Bore	3.24 in (82.5 mm)
Stroke	3.31 in (84.1 mm)
Compression ratio	9.6 : 1
Main crankshaft bearing diameter	1.88 in (48 mm)
Engine management system	Simos 12
Fuel type	Premium 91 AKI
Emissions standard	SULEV
Firing Order	1-3-4-2
Knock control	yes
Turbocharging	yes
Exhaust gas recirculation	internal (camshaft adjustment)
Intake manifold flaps	yes
Intake camshaft adjustment - continuous	yes
Exhaust camshaft adjustment - continuous	no
High pressure injectors (FSI)	yes
Injectors in the intake manifold (MPI)	no
Secondary air system	yes
Audi valvelift system - for exhaust valves	no
Rotary slide valve	yes
Regulated oil pump	yes
Tumble flaps	yes

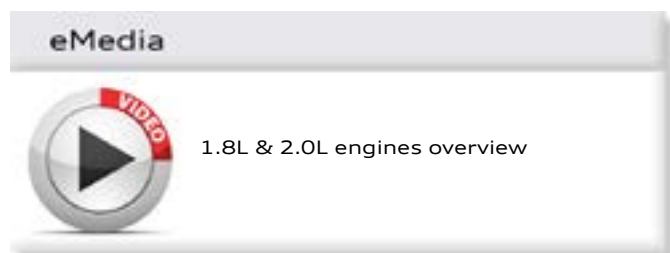

2.0L TFSI engine

Engine code	CNTA	CYFB
Installation position	longitudinal	transverse
Displacement	121.0 cu in (1983 cm ³)	121.0 cu in (1983 cm ³)
Power output	220 hp at 4500 - 6250 (162 kW at 4500 - 6250)	285 hp at 5500 - 6200 (206 kW at 5500 - 6200)
Torque at rpm	258 lb ft at 1500 - 4500 (350 Nm at 1500 - 4500)	280 lb ft at 1800 - 5500 (380 Nm at 1800 - 5500)
Bore	3.24 in (82.5 mm)	3.24 in (82.5 mm)
Stroke	3.65 in (92.8 mm)	3.65 in (92.8 mm)
Compression ratio	9.6 : 1	9.3 : 1
Main crankshaft bearing diameter in mm	52	52
Engine management system	Simos 12	Simos 12
Fuel type	Premium 91 AKI	Premium 91 AKI
Emissions standard	SULEV	LEV3
Firing order	1-3-4-2	1-3-4-2
Knock control	yes	yes
Turbocharging	yes	yes
Exhaust gas recirculation	internal (camshaft adjustment)	internal (camshaft adjustment)
Intake manifold flaps	yes	yes
Intake camshaft adjustment - continuous	yes	yes
Exhaust camshaft adjustment - continuous	yes	yes
High pressure injectors (FSI)	yes	yes
Injectors in the intake manifold (MPI)	no	no
Secondary air system	yes	yes
Audi valvelift system - for exhaust valves	yes	yes
Rotary slide valve	yes	yes
Regulated oil pump	yes	yes
Tumble flaps	no	no
Drumble ¹⁾	yes	yes

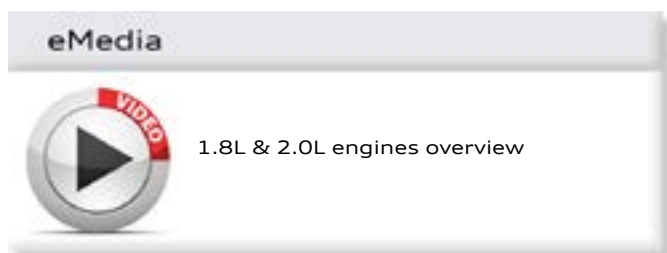

¹⁾ Please see page 64

Engine mechanicals

Overview

In addition to significantly reducing the weight of the cylinder block, a second cooling-side oil gallery has been developed to accommodate the electrically switchable piston cooling jets. The cross-sections of the coolant and oil return lines have been modified and the position of the knock sensors has also been optimized.

The balance shafts are now partially supported by needle bearings to reduce friction and ensure their robustness for start-stop or hybrid applications. The weight of the balance shafts has also been reduced which lowers the inertia required to move them.

The oil return line on the "hot" side of the engine has been completely reconfigured.

Weight saving measures (1.8l TFSI engine)

The third generation of the EA888 engine family delivers a total weight saving of approximately 17.1 lb (7.8 kg). To achieve these savings, the following components have been modified or are used for the first time:

- ▶ Thin-walled cylinder block
- ▶ Integrated coarse oil separator
- ▶ Cylinder head and turbocharger
- ▶ Crankshaft (with smaller main bearing diameters and four counterweights)
- ▶ Die cast aluminium oil pan top section (including aluminium bolts)
- ▶ Plastic oil pan bottom section
- ▶ Aluminium bolts
- ▶ Balance shafts

Cylinder block

The cylinder block has been significantly revised to save weight. The wall thickness has been reduced from approximately 0.13 in (3.5 mm) to 0.11 in (3.0 mm). In addition, the coarse oil separator has been integrated with the block. These modifications result in a weight saving of approximately 5.29 lb (2.4 kg) compared to the second generation engines.

Other modifications are:

- ▶ A second pressurized cooling-side oil gallery for the electrically switchable piston cooling jets
- ▶ Modified coolant and oil return line cross-sections
- ▶ Optimized, long coolant jacket
- ▶ Oil cooler supply via cylinder head coolant return line
- ▶ Optimized knock sensor positionings

Sealing

Both the timing chain cover and a sealing flange on the output side of the cylinder block are sealed using a liquid sealant.

Overview

Timing chain cover

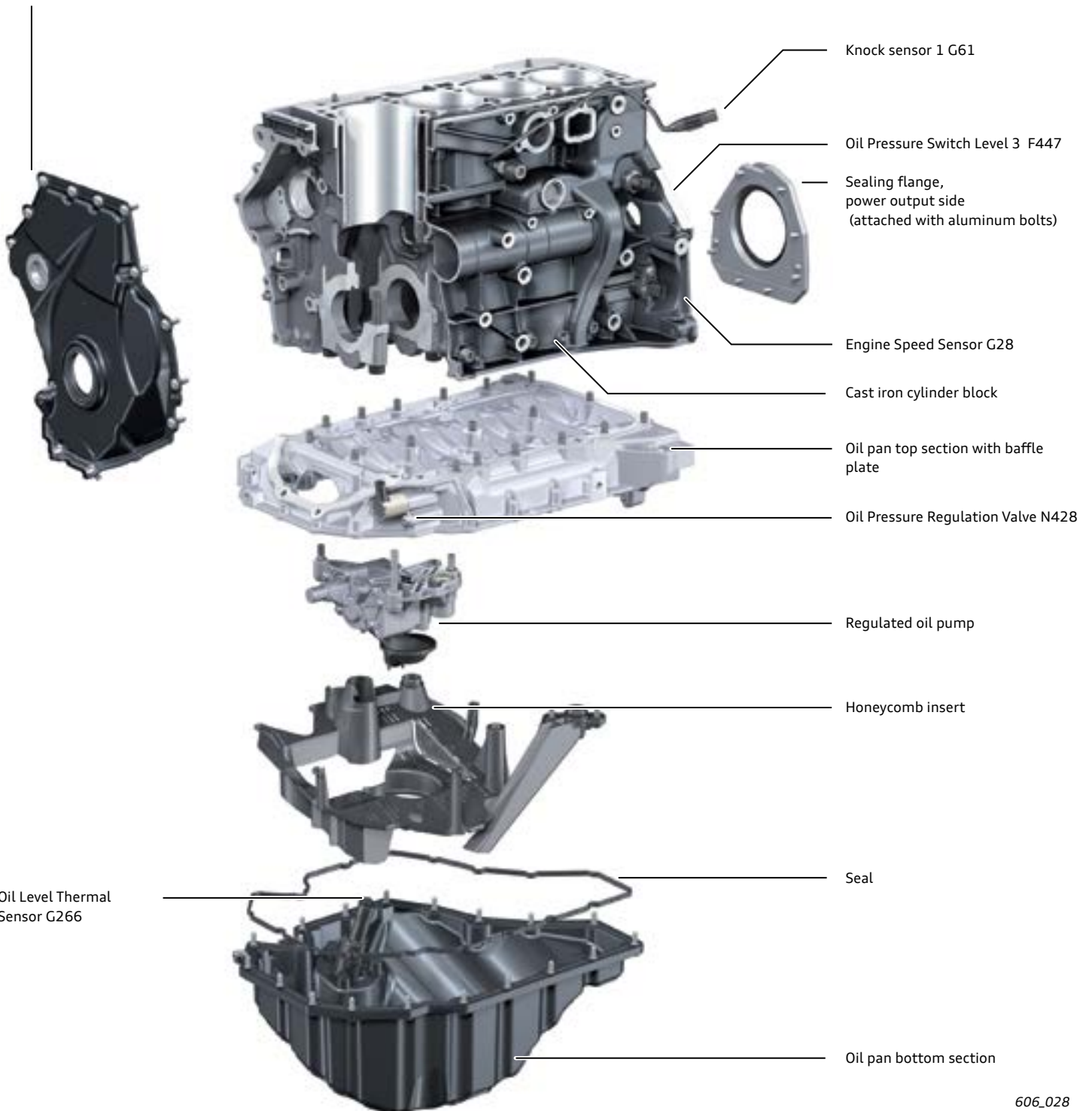

606_028

Oil pan

Oil pan top section

The oil pan top section is made from die cast aluminium. The oil pump and the honeycomb insert for oil intake and oil return are integral with the top section. The oil pan top section also accommodates the pressurized oil galleries and the two-stage oil pump control valve.

It is sealed off from the cylinder block with a liquid sealant and attached by aluminium bolts.

To enhance the acoustic characteristics of the engine assembly, the upper main bearing supports are integral with the top section of the oil pan.

Oil pan bottom section

The oil pan bottom section is made from plastic. This provides a weight savings of approximately 2.2 lb (1 kg). It is sealed to the upper oil pan with a rubber gasket and attached with steel bolts.

Oil Level Thermal Sensor G266 is integrated with the oil pan bottom section. The oil drain plug is made from plastic (bayonet lock).

Crankshaft assembly

Reducing weight and frictional losses was a main developmental goal.

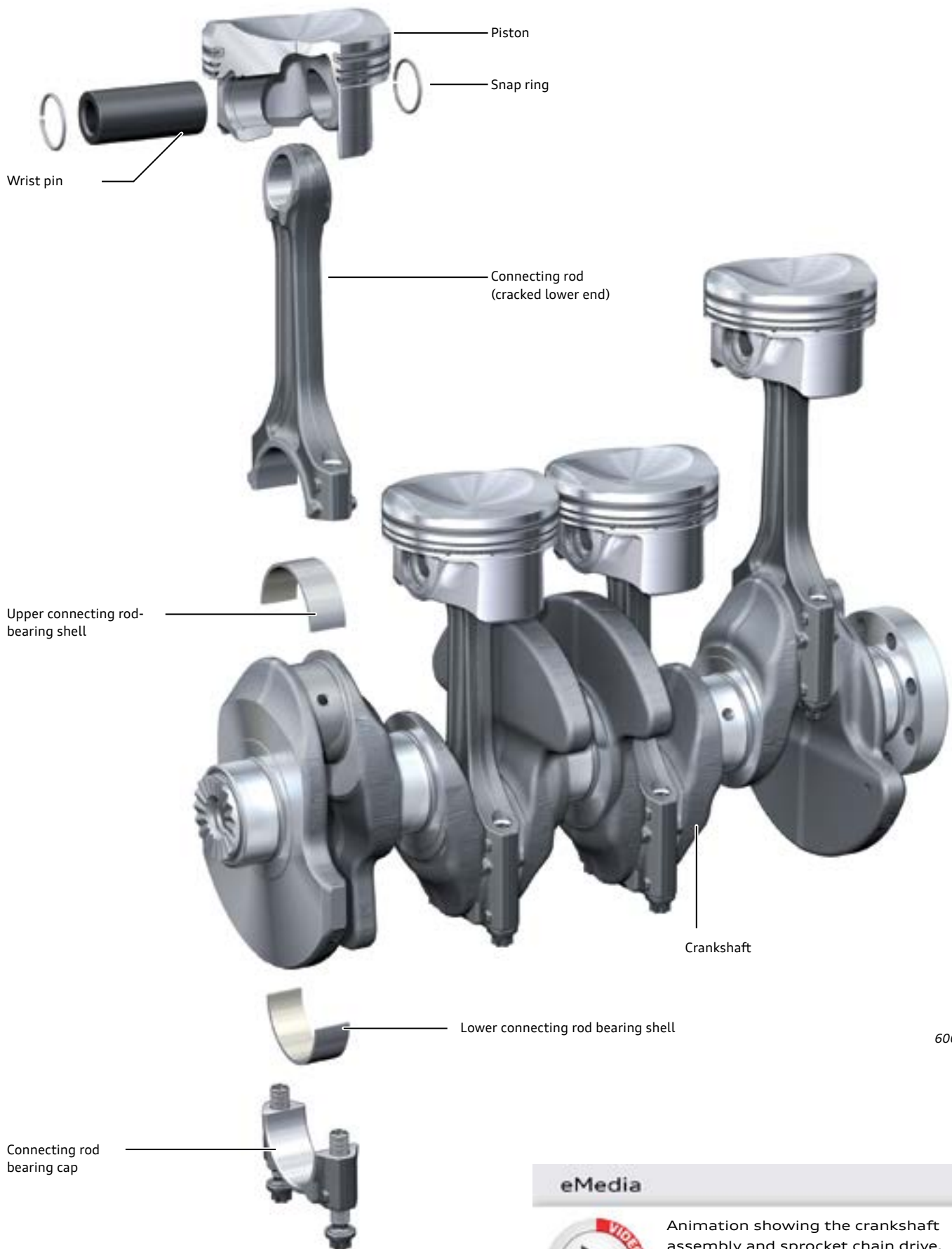

606_030

eMedia



Animation showing the crankshaft assembly and sprocket chain drive, including the drive mechanism for the regulated oil pump and engine coolant pump.

Piston

Piston clearance has been increased in order to reduce friction during the warm-up phase. A wear-resistant piston skirt coating is also used.

- Upper piston ring = taper face ring / on 2.0l engines
Rectangular ring, asymmetrically barrelled
- Middle piston ring = taper face ring
- Upper piston ring = oil control ring (two piece, double bevelled spiral expander ring)

Crankshaft

Compared to the second generation engine, the main bearing diameters of the crankshaft have been reduced from 2.04 in (52 mm) to 1.88 in (48 mm), and the number of counterweights reduced from eight to four. This has reduced the weight of the crankshaft by 3.5 lb (1.6 kg). The upper and lower main bearing shells are a two-layer lead-free composition. This ensures that the crankshaft is suitable for start-stop operation.

Connecting rods/wrist pins

The connecting rods are cracked at the large end.

A significant modification is the elimination of the bronze bushing in the connecting rod small end. The connecting rod is fitted to the wrist pin without using a bushing by a special process patented by Audi AG. The wrist pin is floating and rides directly on the piston without any bushings. A special surface coating known as DLC is applied to the wrist pin.

DLC stands for Diamond like Carbon, an amorphous carbon. DLC strata are very hard and are noted for having very low dry coefficients of friction. They can be identified by their glossy, black-gray surface.

Cradle support

The upper oil pan is bolted to the lower main bearing caps. This modification helps reduce vibration and noise thus enhancing driver comfort.

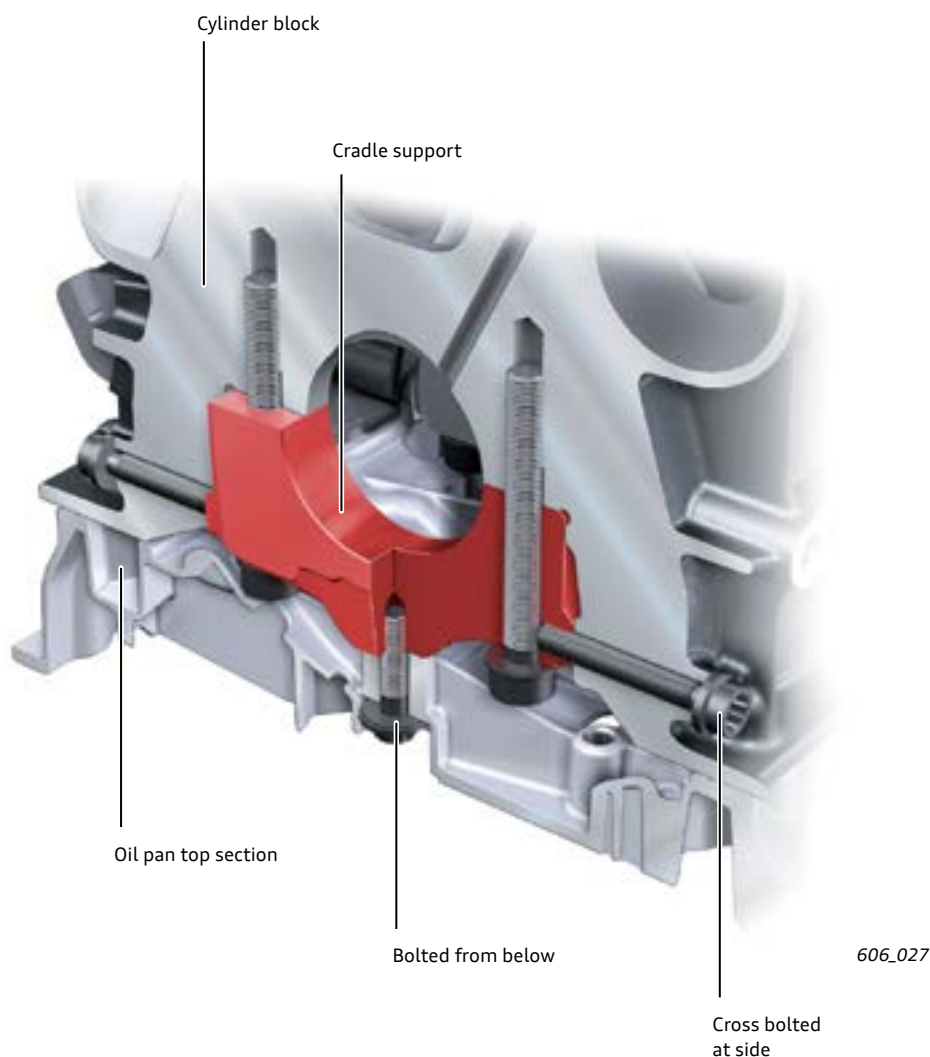

Chain drive

The basic configuration of the chain drive system has been adopted from the second generation engine. However, new design parameters were implemented. Because of the reduction in friction of the drive assemblies, less power is needed to drive the chain mechanism. The chain tensioners have been adapted to operate at lower oil pressures.

There are new chain assembly installation procedures and special tools required for the third generation engine.

In addition, an adaptation procedure must be performed using the Scan Tool after doing work on the chain drive. The adaptation entails making measurements to establish allowable tolerances needed for diagnostic Test Plans.

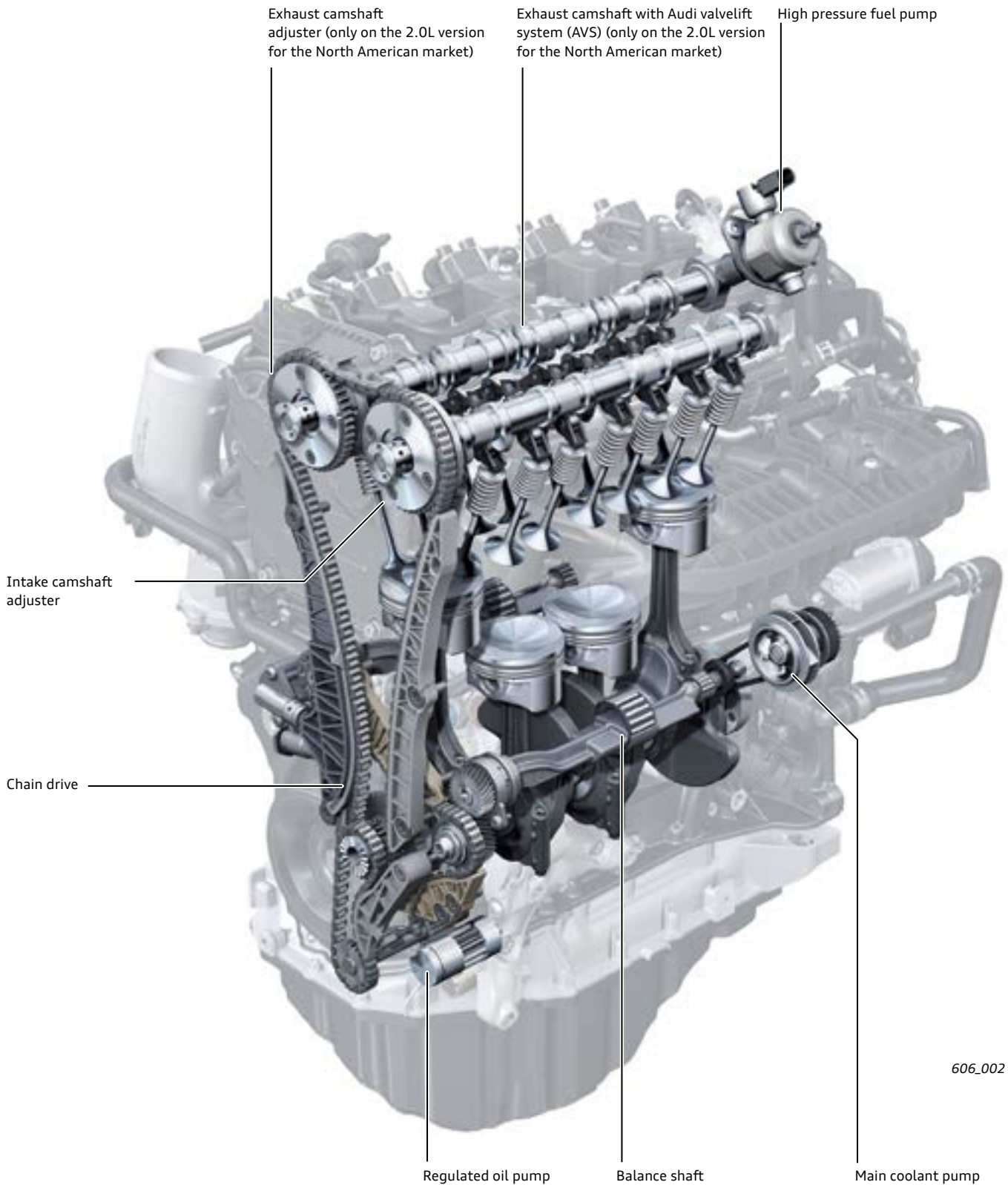

606_002

Balance shafts

In addition to a reduction in overall mass, the balance shafts are now partially supported by needle bearings. This has reduced friction; especially at lower oil temperatures. This modification also increases the suitability of the components for use in start-stop or hybrid applications.

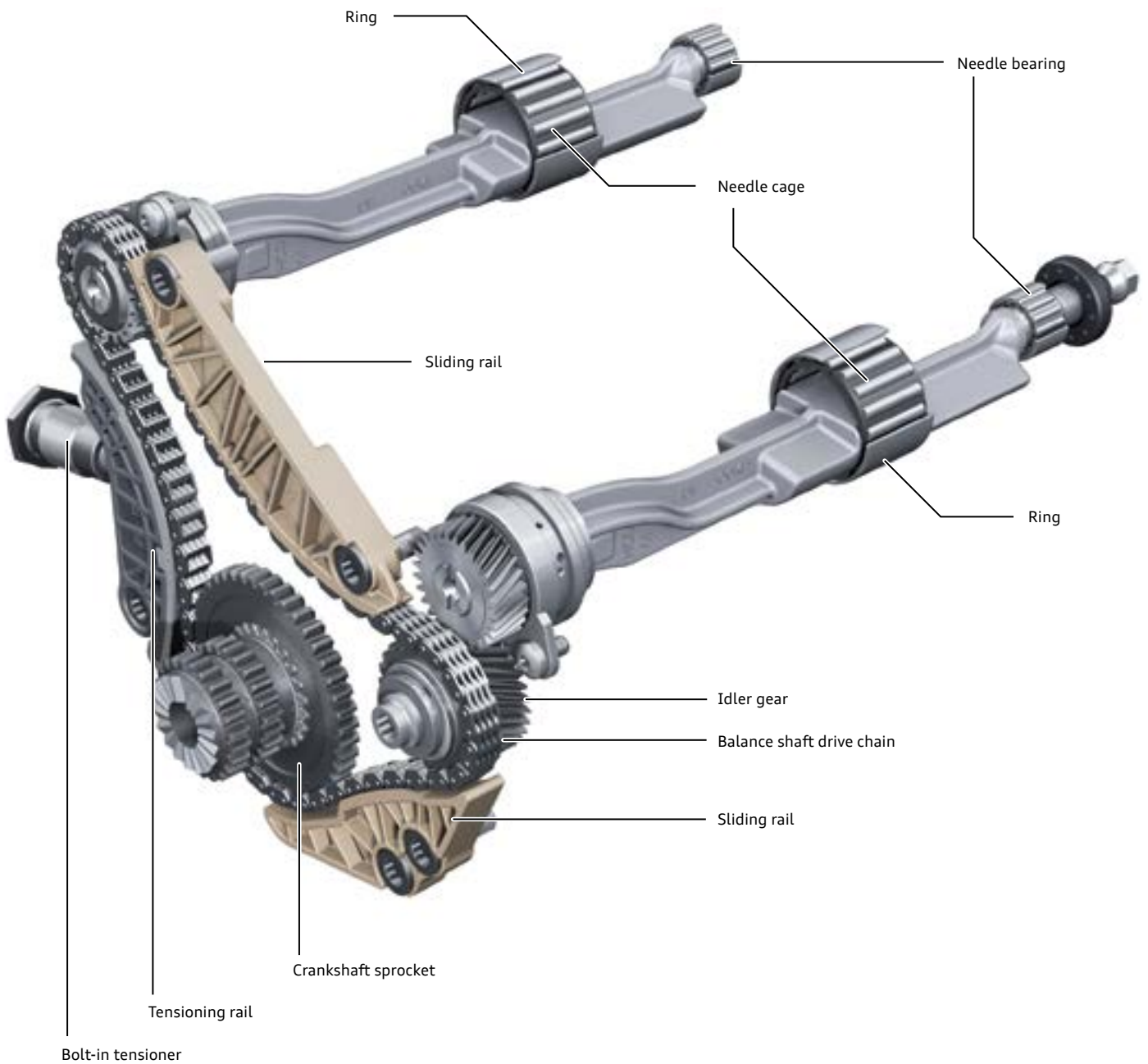

Auxiliaries mounting bracket

Oil filter and oil cooler holders are integrated into the engine auxiliaries mounting bracket. The auxiliaries mounting bracket contains oil ducts and coolant ducts routed to the oil cooler.

The oil filter cartridge is accessible from above. To ensure that no oil is discharged when changing the filter, a sealing element is opened when the filter is released, allowing the oil from the filter to flow back into the oil pan.

The oil pressure switch, the electrical switching valve of the piston cooling jets and the poly-V belt tensioner are integrated in the bracket.

Design (shown using the transverse mounted 1.8l TFSI engine)

Oil ducts

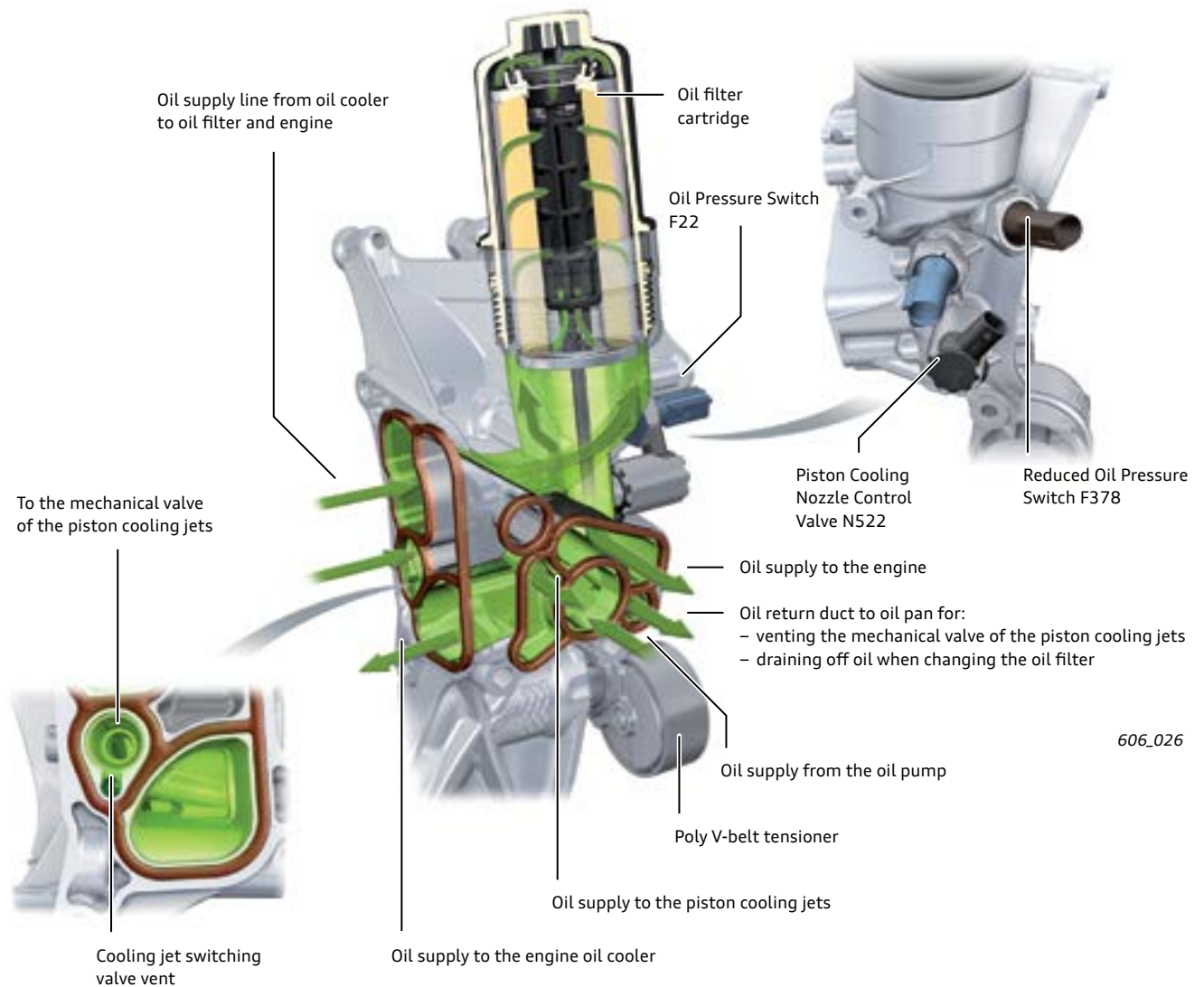

Coolant ducts

The oil supply line for the oil cooler is also integrated into the auxiliaries mounting bracket.

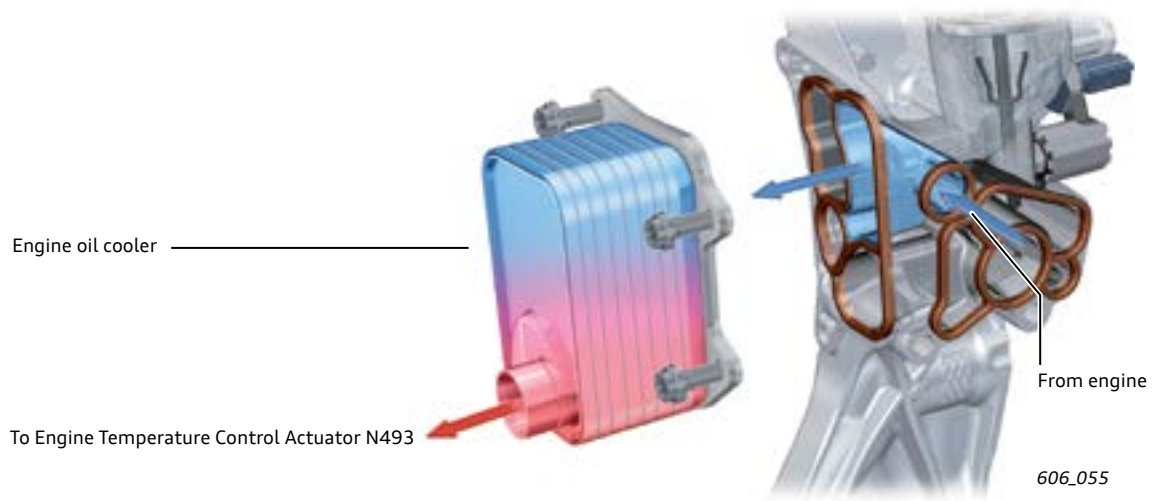

Cylinder head

The cylinder head is a completely new design. It features an integral exhaust cooling and routing system.

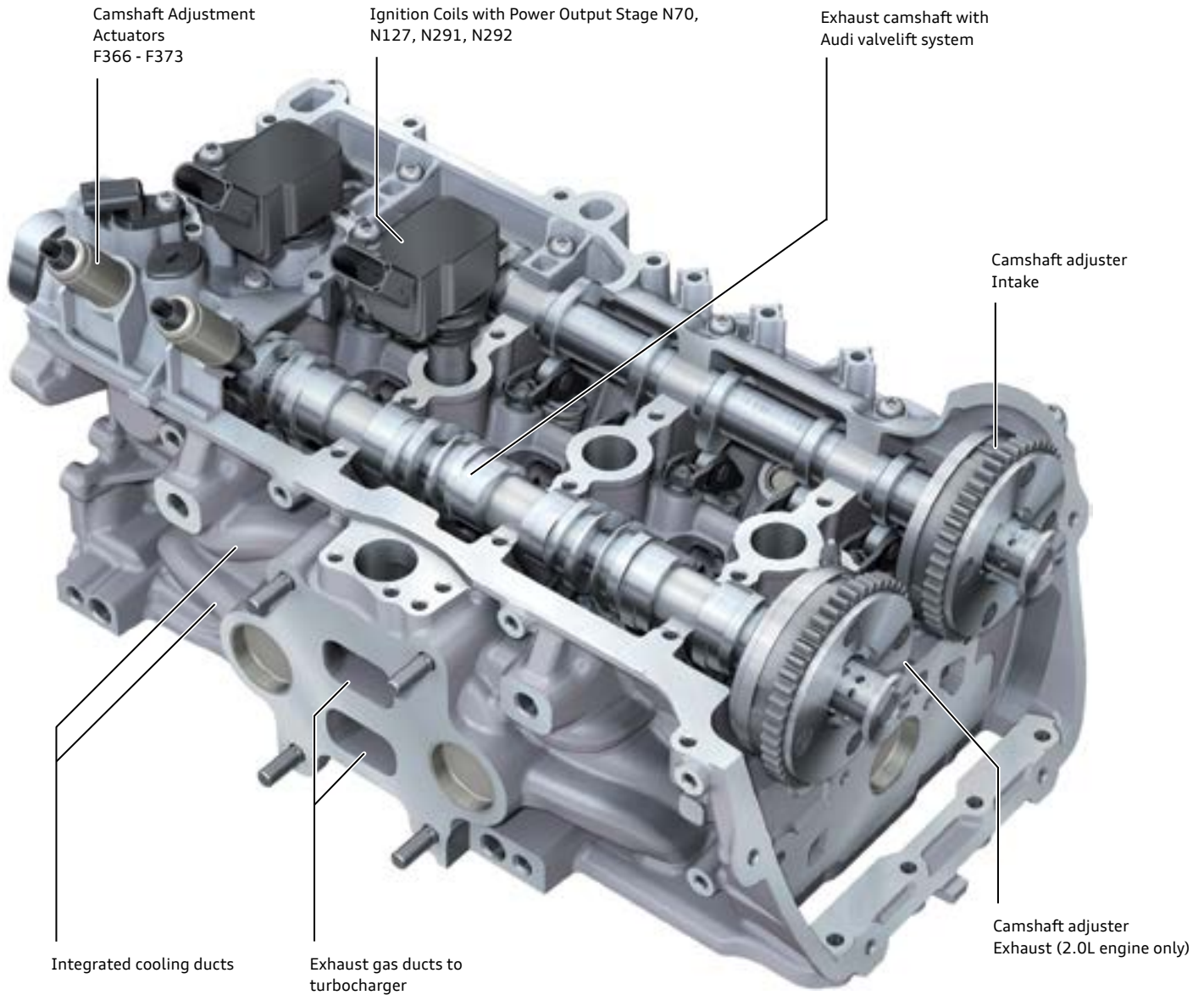

606_006



Note

Only the 2.0L engine will have a continuously adjustable exhaust camshaft and AVS at the introduction of this engine in North America.



Reference

To learn more about the variable valve timing system, refer to eSelf-Study Program 921103, *The Audi 3.0L V6 Engine*.

Design

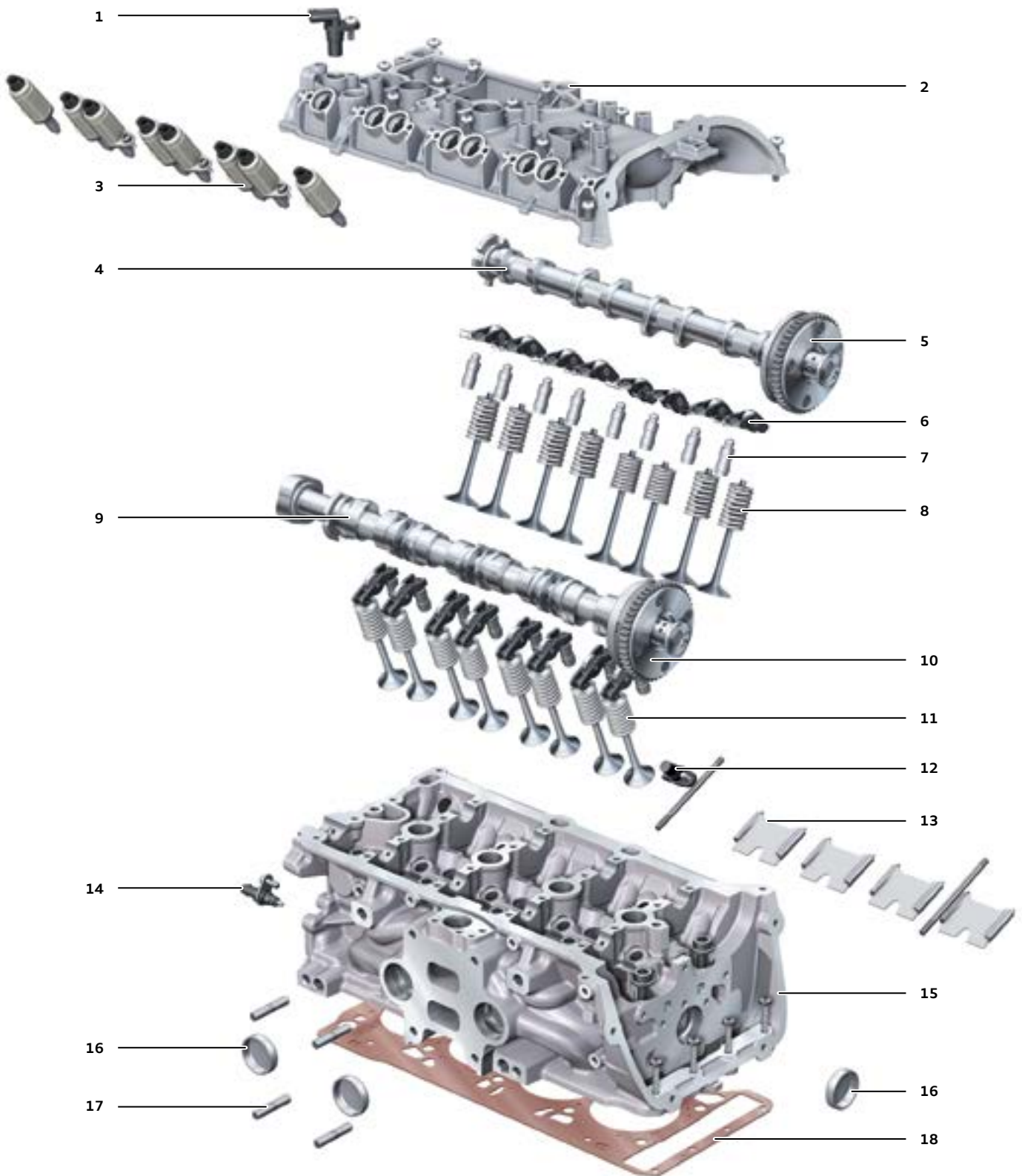

606_031

Key:

- | | | | |
|---|---|----|--|
| 1 | Camshaft Position Sensor 3 G300 | 10 | Exhaust camshaft adjuster (2.0L engine only) |
| 2 | Cylinder head cover | 11 | Exhaust valve |
| 3 | Camshaft Adjustment Actuators F366 - F373 (2.0L only) | 12 | Camshaft Position Sensor G40 |
| 4 | Intake camshaft | 13 | Port dividers |
| 5 | Intake camshaft adjuster | 14 | Engine Coolant Temperature Sensor G62 |
| 6 | Roller-type cam follower | 15 | Cylinder head |
| 7 | Support element | 16 | Freeze plug |
| 8 | Intake valve | 17 | Integral exhaust manifold stud |
| 9 | Exhaust camshaft | 18 | Cylinder head gasket |

Sealing

The cylinder head cover is attached with steel bolts and sealed with a liquid sealant.

The cylinder head gasket is two layer metal gasket.

Audi valvelift system (AVS)

The Audi valve lift system has been developed to optimize the change cycles of the dual fuel injection system. AVS is used when changing between FSI and MPI operation of the engine. Initially it will only be installed on the exhaust camshaft of the 2.0L version of the EA888 3rd generation engine even though the dual injection system will not be utilized.

Camshaft adjuster

Another key modification is the use of a camshaft adjuster on the exhaust camshaft. This maximizes the scope for charge cycle management. The AVS system and the exhaust camshaft adjustment make it possible to adapt to the various charge cycle requirements at full and partial throttle.

The result is rapid torque delivery. The high torque level across a wide rpm range allows the transmission ratios to be adapted differently (downspeeding). This improves fuel economy.

Other modifications:

- ▶ Long spark plug threads
- ▶ New ignition coils (retained by bolts, discrete ground wires)
- ▶ Weight-optimized camshafts
- ▶ Optimized roller cam followers (for reduced friction)
- ▶ Reduced spring forces in valve gear
- ▶ New oil filler cap integrated into the upper chain case
- ▶ Engine Coolant Temperature Sensor G62 integrated into the cylinder head (ITM)
- ▶ Repositioned high pressure fuel pump
- ▶ Improved fine oil separator
- ▶ The turbine housing of the exhaust turbocharger is bolted directly to the cylinder head
- ▶ Optimization of the intake ports
- ▶ Improvement of the fuel injection components including sound insulation



Note

There are also several changes relevant to assembly work on the cylinder head. For a detailed description of the procedure, please refer to the relevant repair information.

Integral exhaust manifold

A cooled exhaust manifold with cylinder sequence separation is directly integrated with the cylinder head.

The use of this manifold significantly lowers the exhaust temperature upstream of the turbine when compared to a conventional manifold layout. In addition, a highly heat resistant turbocharger is used.

Because of the new manifold design, there is no longer a need for full throttle mixture enrichment to protect the turbocharger turbine during high speed engine operation. This improves fuel economy during normal operation and when driving in a more aggressive, sporty manner.

The integral exhaust manifold facilitates rapid coolant heating and therefore, is a key part of the thermal management system.

Exhaust ports

The exhaust ports are designed so that exhaust gases from one cylinder do not interfere with the purging process of other cylinders.

The full energy of the exhaust gas flow is available for driving the turbocharger. The exhaust ports of cylinders 1 and 4 as well as cylinders 2 and 3 converge at the transition to the turbocharger.

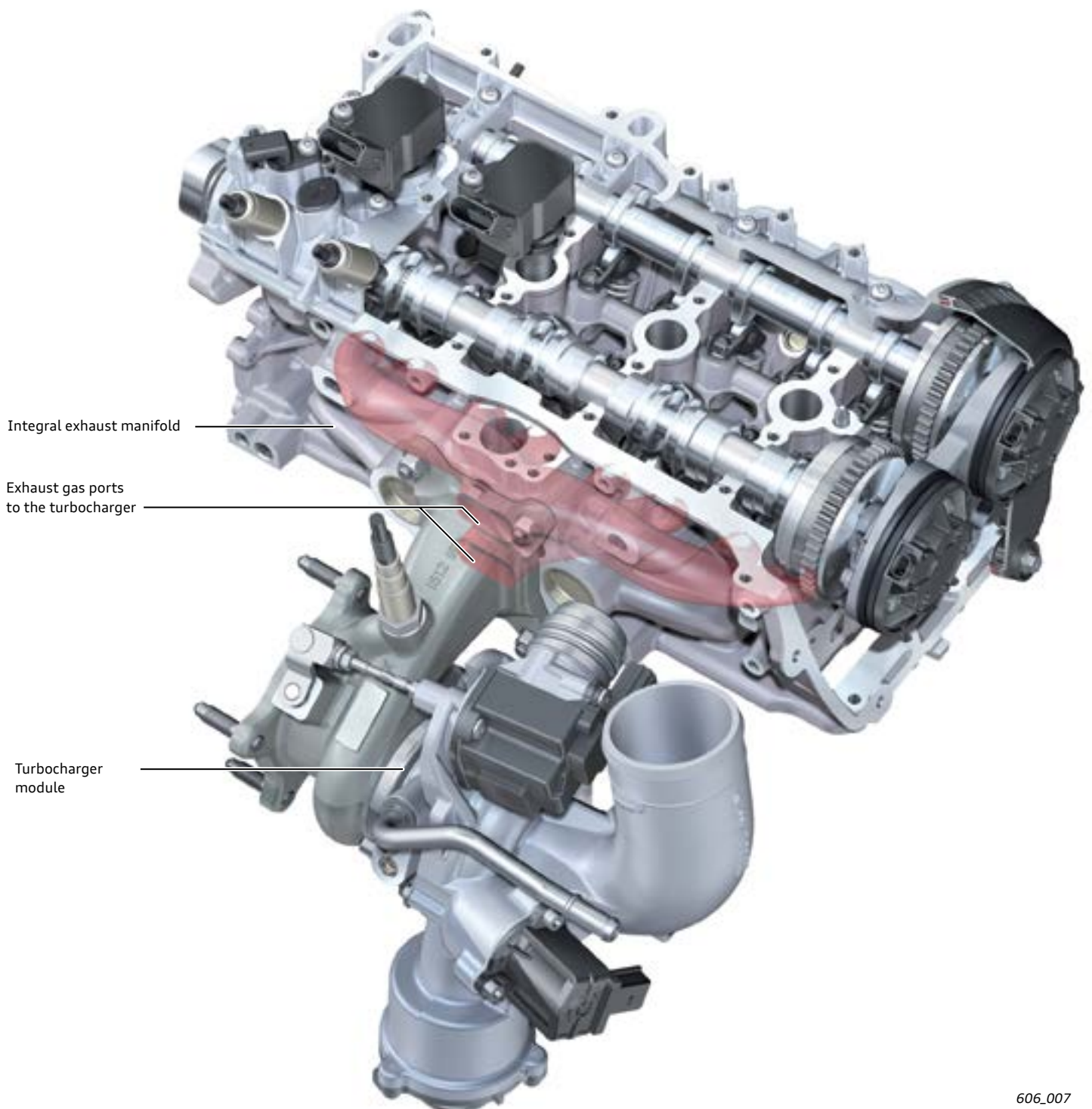

Cooling of the integral exhaust manifold

The integral exhaust manifold facilitates rapid heating of the coolant and, therefore, is an integral part of the thermal management system.

During the warm-up phase, heat is transferred to the coolant within a very short period of time. This heat is directly utilized to heat the engine and passenger compartment. Due to the reduced heat loss, the downstream components - oxygen sensor, turbocharger and catalytic converter - are able to reach their optimal operating temperature more quickly.

The system goes into cooling mode even after a short warm-up phase. This is necessary because the coolant in proximity to the integral exhaust manifold would otherwise boil off very quickly. For this reason, Engine Coolant Temperature Sensor G62 is installed at the hottest point in the cylinder head.

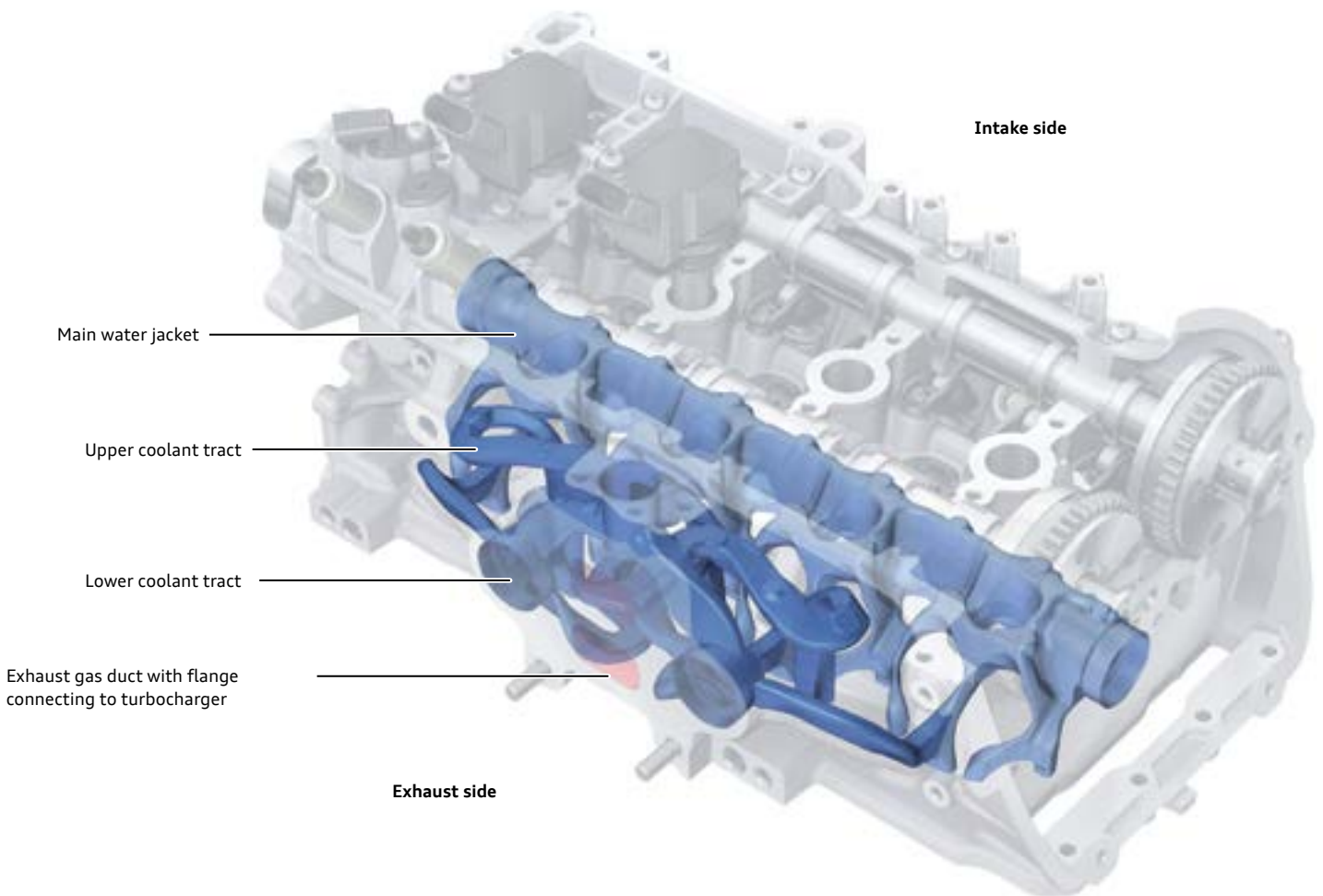

606_032

eMedia



Animation showing the cylinder head and the integral exhaust manifold.

Positive crankcase ventilation

The positive crankcase ventilation system has also been systematically improved. The cylinder block pressure to ambient air pressure ratio is configured for a high pressure gradient.

A strong emphasis has been placed on reducing the number of components. On the exterior of the engine, for example, there is now only one pipe for the discharge of cleaned blow-by gases.

The system comprises the following components:

- ▶ Coarse oil separator integrated with cylinder block
- ▶ Fine oil separator module, bolted onto the cylinder head cover
- ▶ Hose for the discharge of cleaned blow-by gases
- ▶ Oil return line in the cylinder block with shutoff valve in the oil pan honeycomb insert

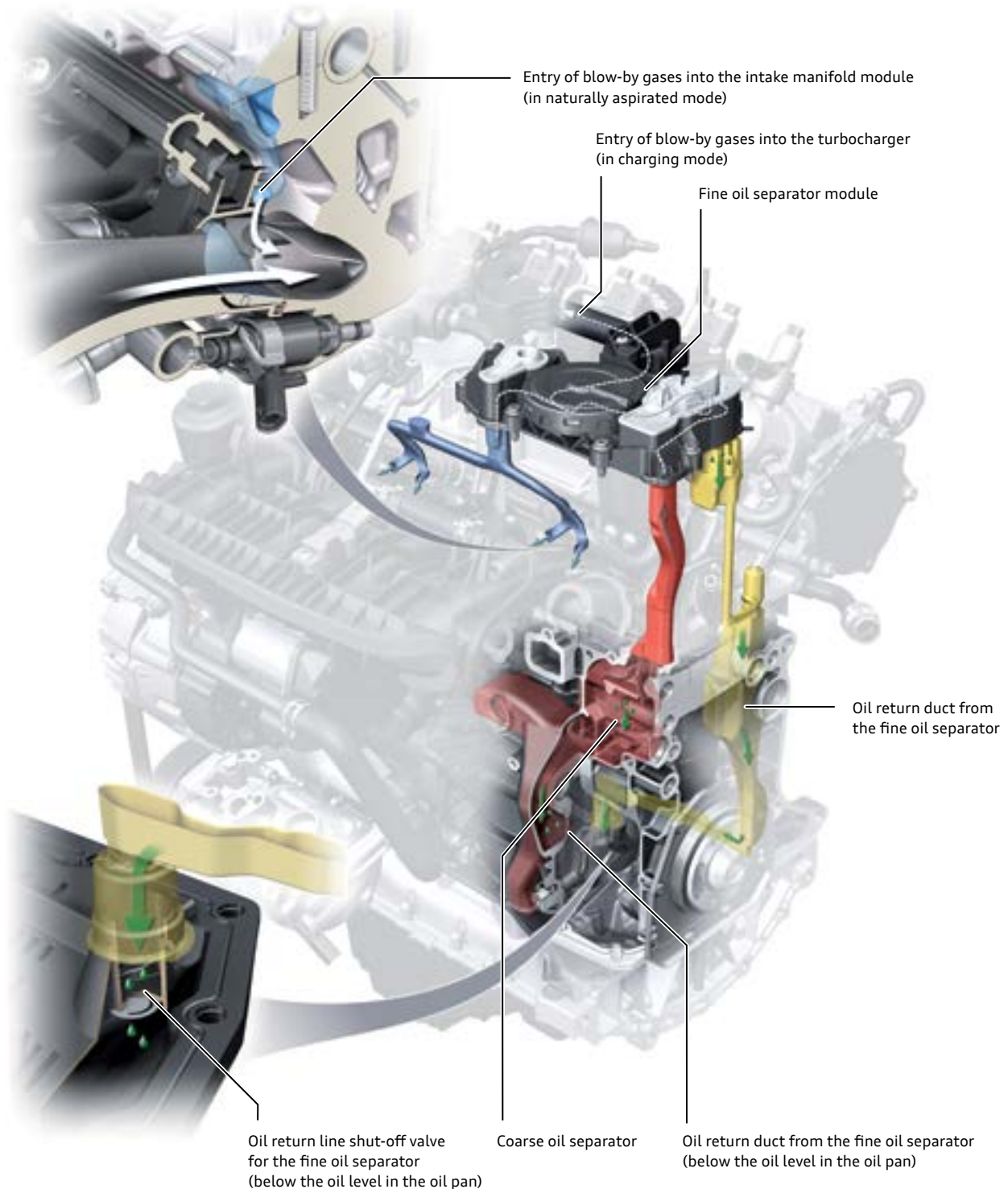

Coarse oil separation

The coarse oil separator function is an integral part of the cylinder block. A portion of the oil is separated by changing the direction of oil flow in a labyrinth.

The separated oil returns to the oil pan via the return duct in the cylinder block. The end of the duct is below the oil level.

Fine oil separation

The coarsely cleaned blow-by gases flow from the cylinder block into the fine oil separator module through a duct in the cylinder head.

Here, the gases are cleaned in a cyclone separator. The separated oil from the cyclone separator returns to the oil pan through a separate duct in the cylinder block. The end of this duct is below the oil level.

A shutoff valve prevents oil from being drawn in from the oil pan in unfavorable pressure conditions.

A sporty driving style (high transverse acceleration) could potentially expose the immersed oil return line because of the oil sloshing inside the oil pan. In this case, too, the shutoff valve keeps the oil return line closed. The shutoff valve is a shutter-type valve.

The cleaned blow-by gases are directed into the combustion chamber via the single-stage pressure control valve. The pressure control valve is rated for a pressure difference of -1.45 psi (-100mBar) relative to the ambient air. The point at which the blow-by gases are admitted into the combustion chamber is dictated by the pressure ratio in the air supply system.

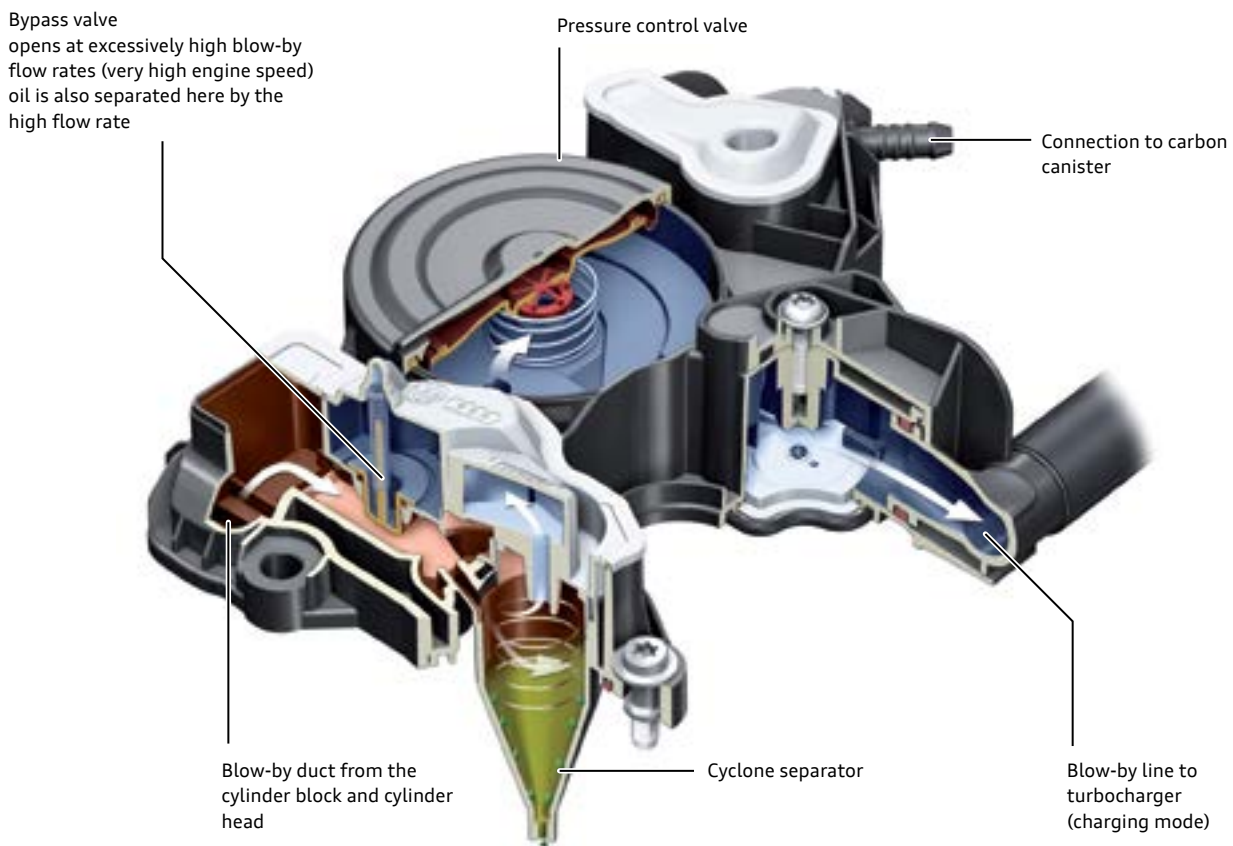

Supply of cleaned blow-by gases to the combustion chamber

After the blow-by gases have been cleaned of fine oil droplets and allowed to flow through the pressure control valve, they are admitted into the combustion chamber. Gas flow is controlled automatically by self-actuating non-return valves integrated into the fine oil separator module.

Faulty installation detection

Emission regulations require that safeguards be provided to detect faulty installation of these components.

If the venting line on the crankcase breather module is not installed (or not properly installed) an installation detection contact opens.

This contact is connected directly to the air intake side of the cylinder head. The engine immediately begins to induct unmetred air which is detected by the oxygen sensors.

The non-return valves return to their initial position when the engine is shut off. The non-return valve facing the exhaust turbocharger is open, while the non-return valve facing the intake manifold is closed.

Full throttle operation (charging mode)

Since pressure is now present throughout the charge air tract, non-return valve 1 closes.

The difference between the pressure inside the crankcase and the pressure on the intake side of the turbocharger causes non-return valve 2 to open.

The cleaned blow-by gases are inducted by the compressor.

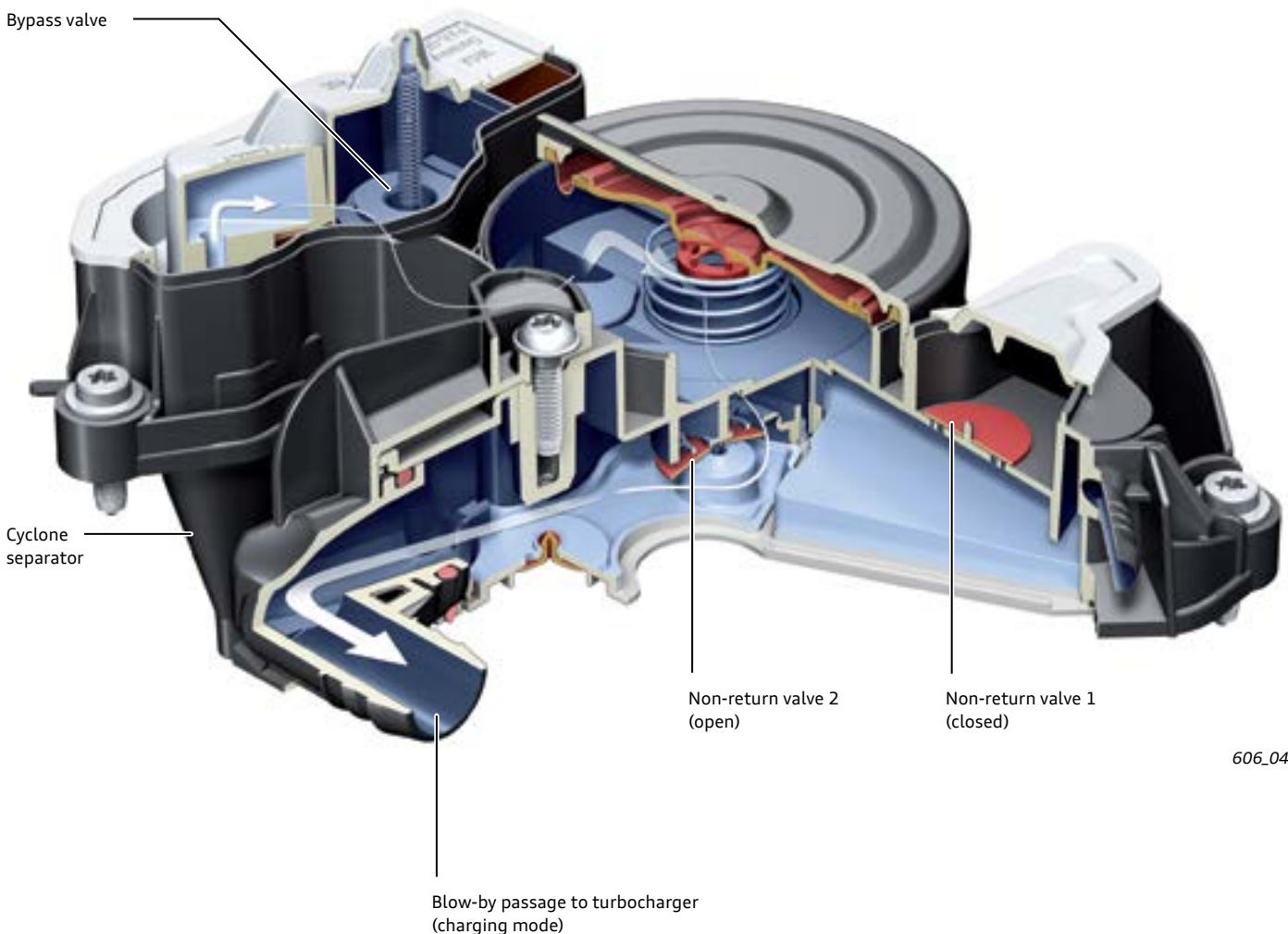

606_047

Idle and partial throttle operation (naturally aspirated mode)

In naturally aspirated mode, non-return valve 1 is opened by the vacuum present in the intake manifold and non-return valve 2 is closed.

The cleaned blow-by gases are admitted directly into the combustion chamber via the intake manifold.

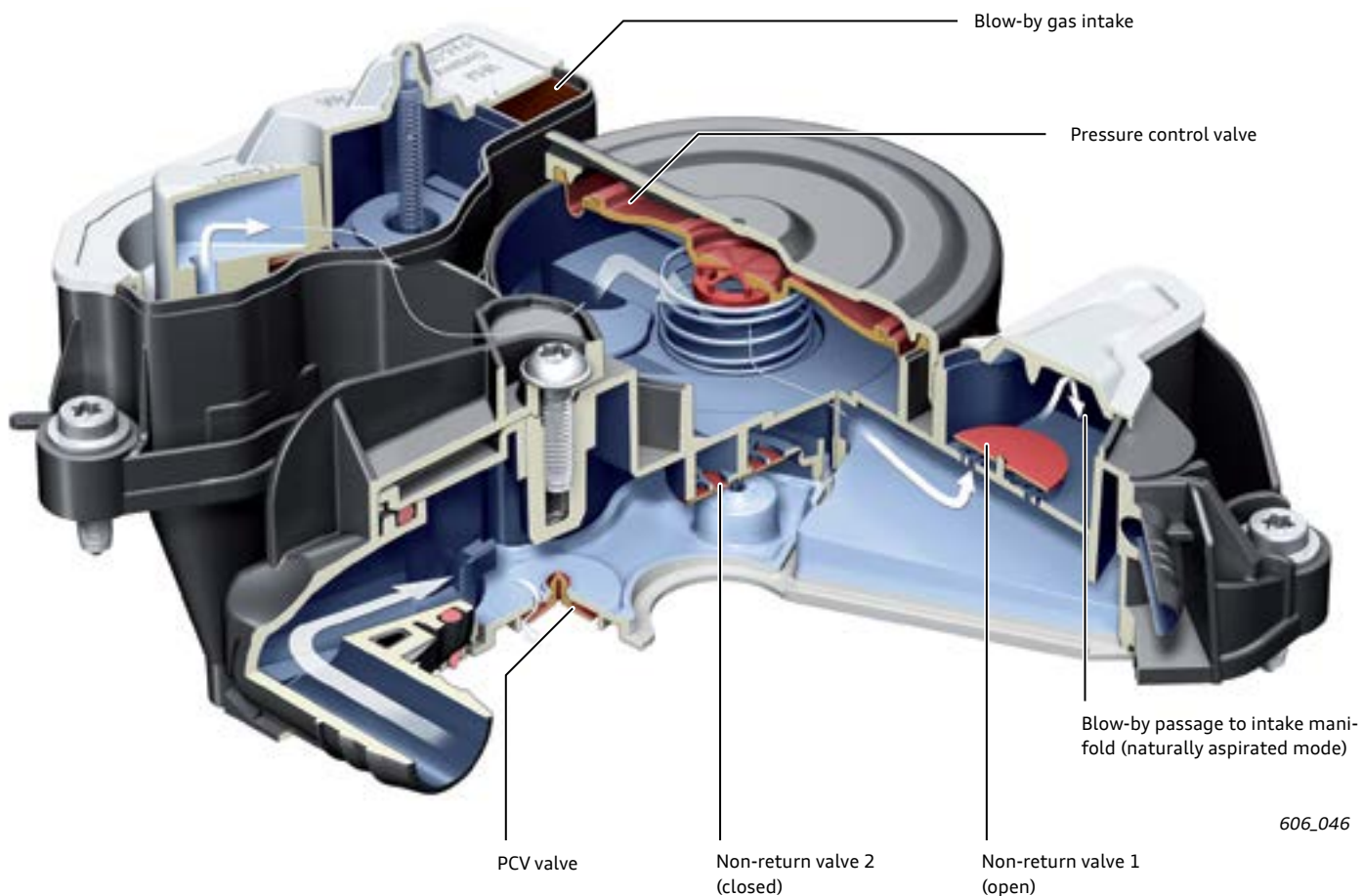

606_046

Positive crankcase ventilation

The crankcase breather is installed in a module on the camshaft cover together with the fine oil separator and the pressure regulator.

The crankcase is vented via the venting line connected upstream of the turbine and a calibrated port in the crankcase breather valve.

The system is therefore designed in such a way that it is only vented when the engine is running in naturally aspirated mode.

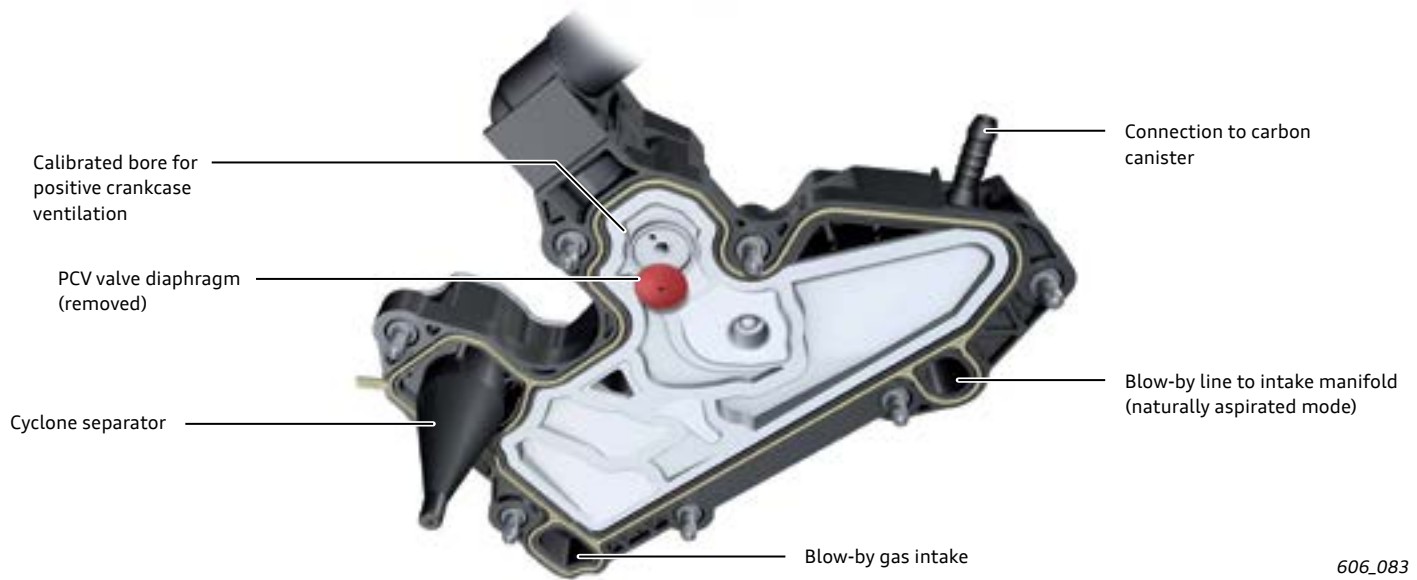

606_083

Oil supply

System overview

Key:

- A Camshaft bearing
- B Support element
- C Balancer shaft bearing
- D Exhaust balancer shaft bearing 1
- E Connecting rod
- F Main bearings 1 - 5

- 1 Exhaust Camshaft Adjustment Valve 1 N318
- 2 Hydraulic vane cell adjuster (exhaust)
- 3 Non-return valve, integrated. into bearing bridge
- 4 Mesh oil filter
- 5 Camshaft Adjustment Valve 1 N205
- 6 Hydraulic vane cell adjuster (intake)
- 7 Non-return valve, integrated into cyl. head
- 8 Fine oil separator
- 9 Vacuum pump
- 10 Flow restrictor
- 11 Lubrication of cam for high pressure fuel pump
- 12 Oil cooler
- 13 Non-return valve, integrated into oil filter
- 14 Oil filter
- 15 Oil drain valve
- 16 Oil Pressure Switch F22 33.3 - 43.5 psi (2.3 - 3.0 bar)
- 17 Reduced Oil Pressure Switch F378 7.25 - 11.6 psi (0.5 - 0.8 bar)
- 18 Piston Cooling Nozzle Control Valve N522
- 19 Mechanical switching valve
- 20 Chain tensioner for balancer shafts
- 21 Chain tensioner for timing gear
- 22 Turbocharger
- 23 Coarse oil separator
- 24 Oil Pressure Switch Level 3 F447
- 25 Lubrication of gear step
- 26 Oil Level Thermal Sensor G266
- 27 Cold start valve
- 28 Non-return valve, integrated into oil pump
- 29 Regulated oil pump
- 30 Oil Pressure Regulation Valve N428

- █ High pressure circuit
- █ Low pressure circuit

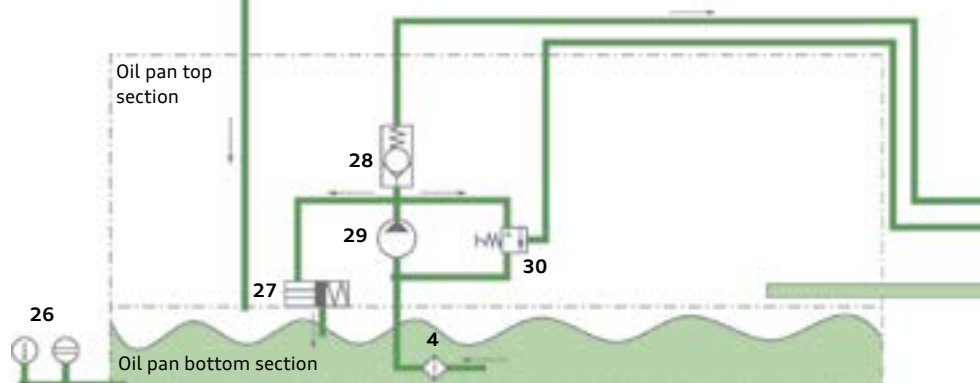
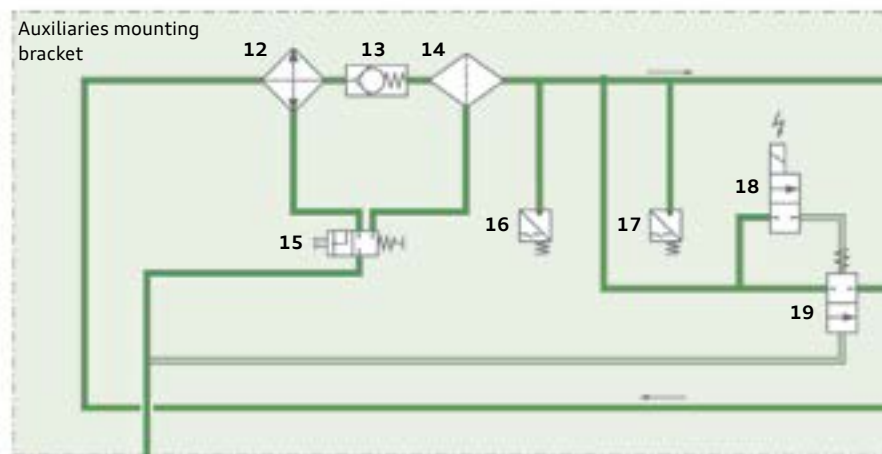
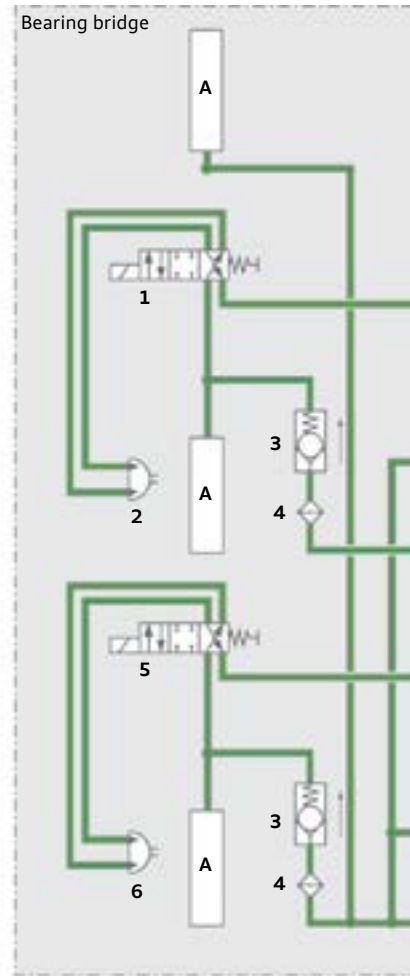

Oil supply

The engine lubrication system has been redesigned. The main points are:

- ▶ Optimization of the pressure ducts in the oil system, reducing pressure losses while simultaneously increasing volume
- ▶ Reduction of pressure losses in the pressurized oil galleries
- ▶ Extension of the rpm range in the low pressure stage
- ▶ Oil pressure reduction in the low pressure stage
- ▶ Switchable piston cooling jets

Together, these modifications have reduced friction within the engine assembly thus improving fuel economy still further.

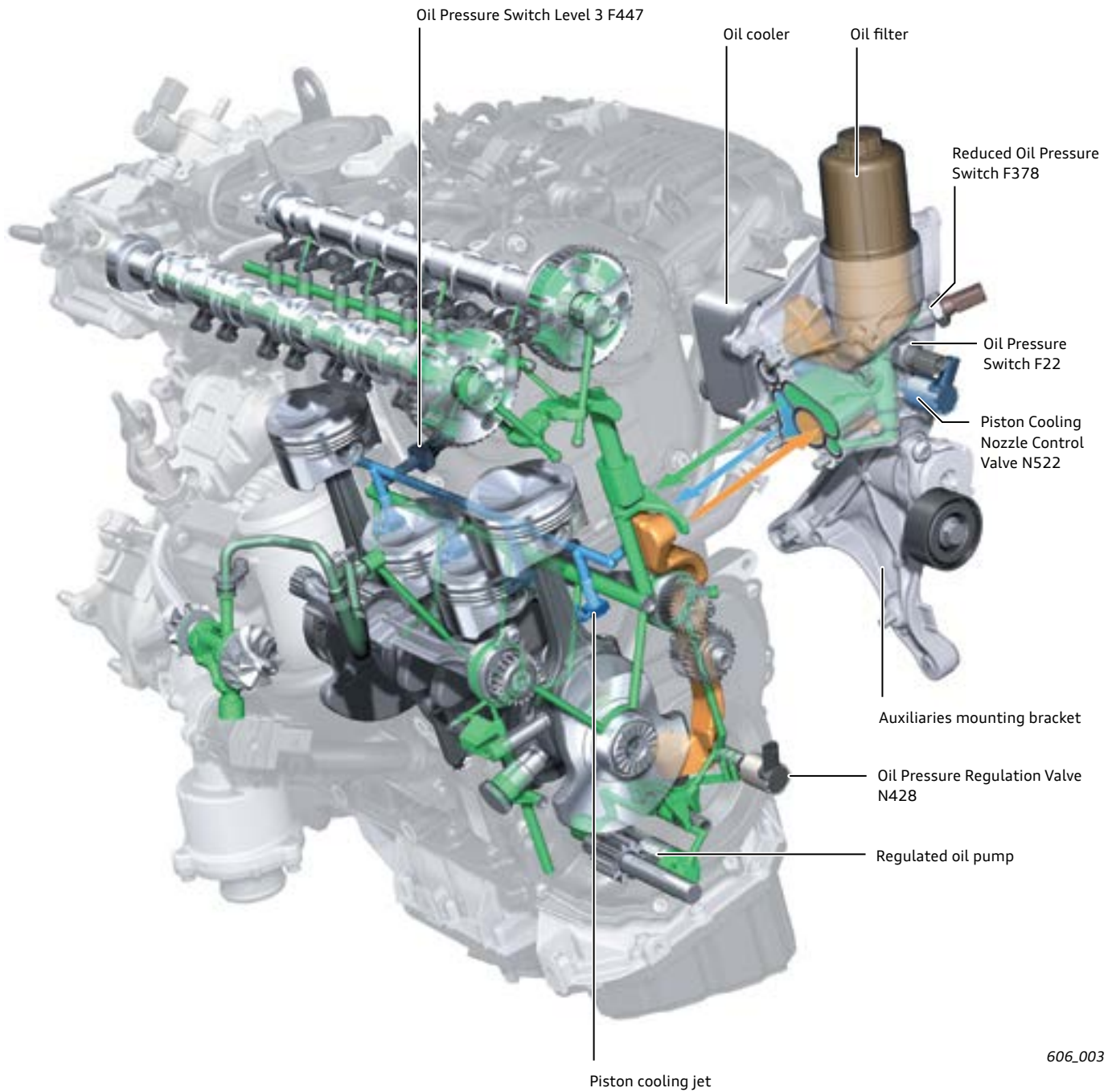

606_003

- Raw oil
- Clean oil
- Switchable piston cooling jets

Modifications to the oil pump:

- ▶ Modified pressure level
- ▶ Higher efficiency
- ▶ Modifications to the hydraulic control system

Regulated oil pump

The functional principle of the engine oil pump is similar to that of the second generation engine with the following differences:

- ▶ The hydraulic control system within the pump has been improved, enabling the pump to control oil flow with even greater precision.
- ▶ The pump drive ratios have been modified ($i = 0.96$) so that the pump now runs more slowly.



606_033

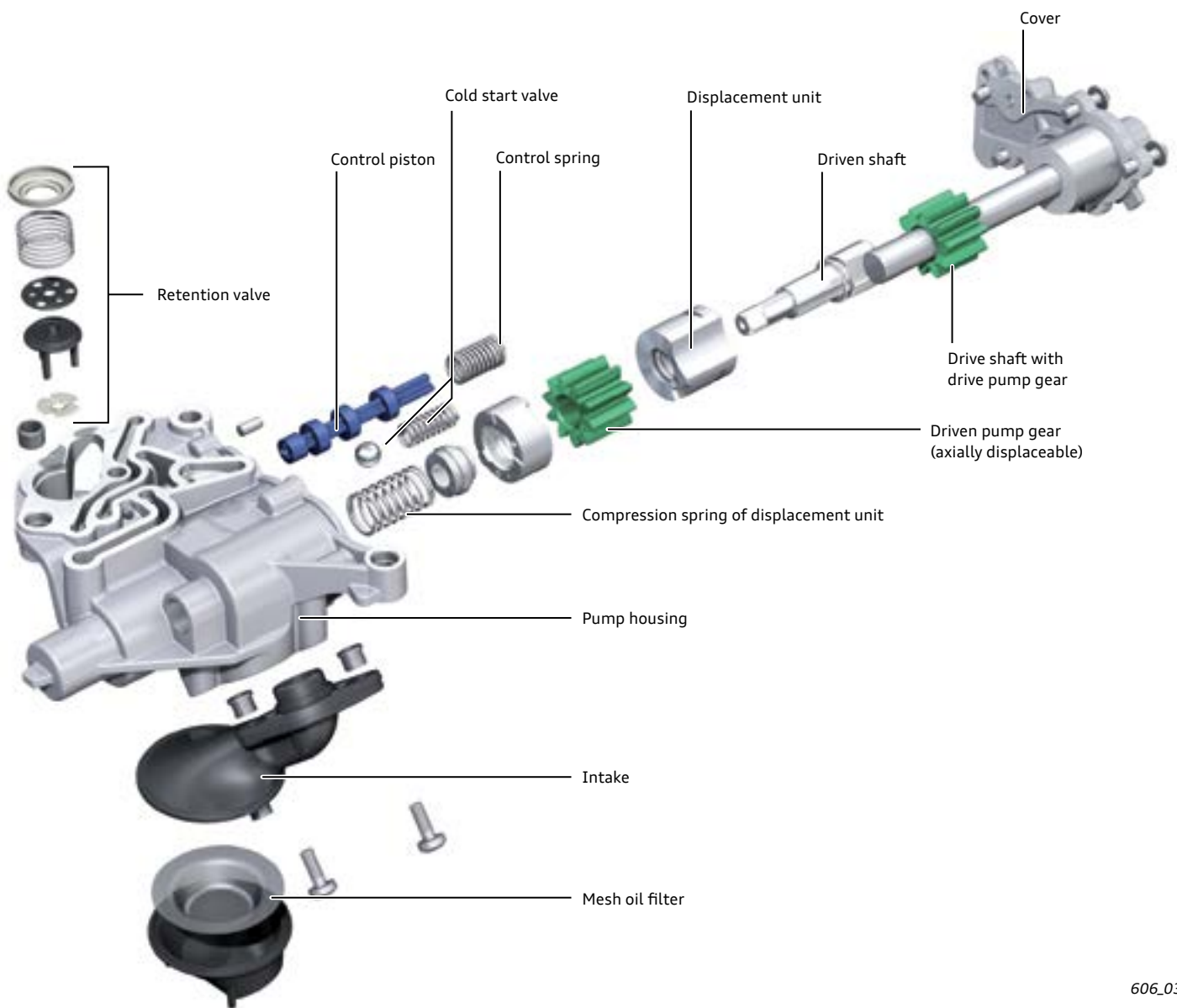

606_034



Reference

To find out more about the function and design of the regulated oil pump, refer to eSelf-Study Program 922903, *The 2.0L 4V TFSI Engine with AVS*.

Oil filler cap

A new style engine oil filler cap is installed on the camshaft chain cover. It has been design to ease the opening and closing action and seal the engine bay from the environment in a safe, oil-tight manner.

The seal and bayonet lock of the new style cap are functionally separate. The sealing face of the elastomer rectangular seal is smaller. No relative movement occurs between the seal and the camshaft chain cover when it is installed. This minimizes the actuation forces. The bayonet lock secures the cap by turning at 90 degree intervals.



606_082

Switchable piston cooling jets

The switchable piston cooling jets system includes the following components:

- ▶ Additional pressurized oil duct in cylinder block
- ▶ New piston cooling jets without spring valves; there are jets with two different internal diameters (the jets of the 1.8l TFSI engines have smaller diameters).
- ▶ Oil Pressure Switch Level 3 F447
- ▶ Piston Cooling Nozzle Control Valve N522
- ▶ Mechanical switching valve

It is not necessary to cool the piston crowns in every operating situation.

By replacing the previously spring controlled cooling jets with electrically control jets and selectively shutting them off, it is possible to reduce the overall oil pressure level. This is turn reduces the load on the engine oil pump and improves fuel economy.

Piston cooling jet control

The piston cooling jets are activated only when required. This calculation is made on the basis of a special map stored in the engine control module

The piston cooling jets can be activated both in the low and high pressure stages.

The key calculation factors are:

- ▶ Engine load
- ▶ Engine speed
- ▶ Calculated oil temperature

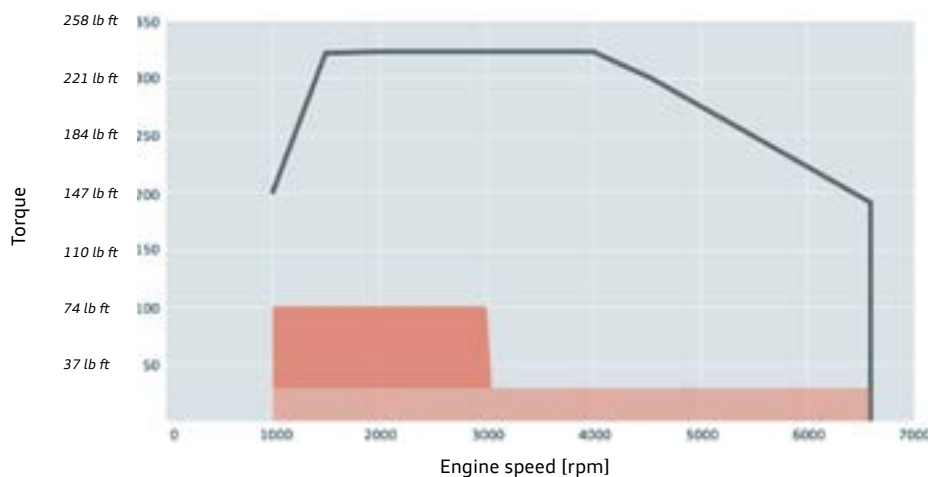

606_019

Piston cooling switched off - oil temperature < 122 °F (50 °C)
 Piston cooling switched off - oil temperature > 122 °F (50 °C)

Piston cooling jets deactivated

Piston Cooling Nozzle Control Module N522 is energized by the Engine Control Module.

When energized, the control channel for the mechanical switching valve opens. Pressurized oil acts directly on both sides of the piston of the mechanical switching valve. The spring displaces the valve and closes the passage to the oil gallery of the piston cooling jets.

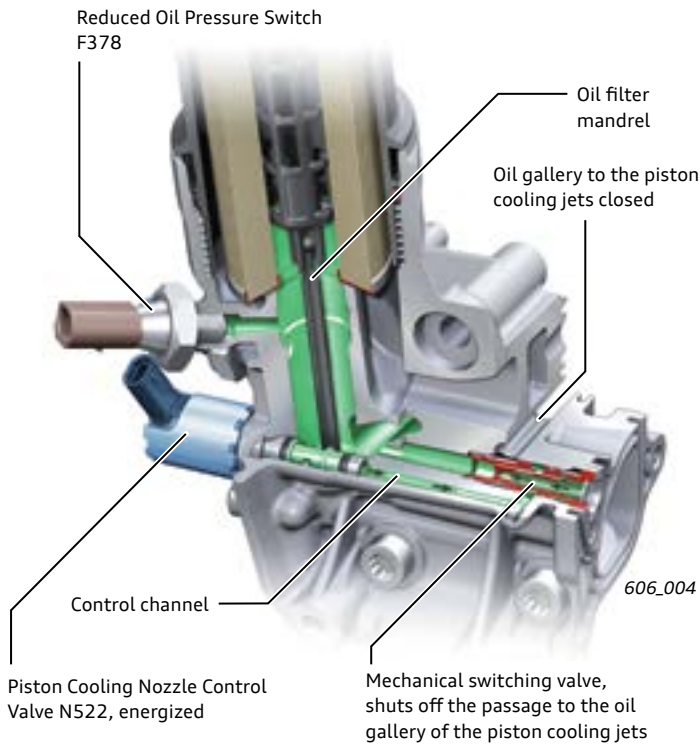

Piston cooling jets activated

The piston cooling jets spray when N522 is de-energized. When N522 is de-energized, the control channel to the mechanical switching valve is no longer supplied oil pressure to both sides of the valve. The mechanical valve therefore moves and opens the duct to the oil gallery of the piston cooling jets. The spring in the switching valve is pre-tensioned. The spring force keeps the oil gallery to the piston cooling jets shut at oil pressures of 13.0 psi (0.9 bar) or higher.

To enable the switching valve to immediately return to its initial position after N522 is de-energized, the oil from the control piston must drain off quickly. There is a separate oil passage which allows the oil to drain without pressure into the engine oil pan. This is the same oil passage that oil drains into when replacing the oil filter.

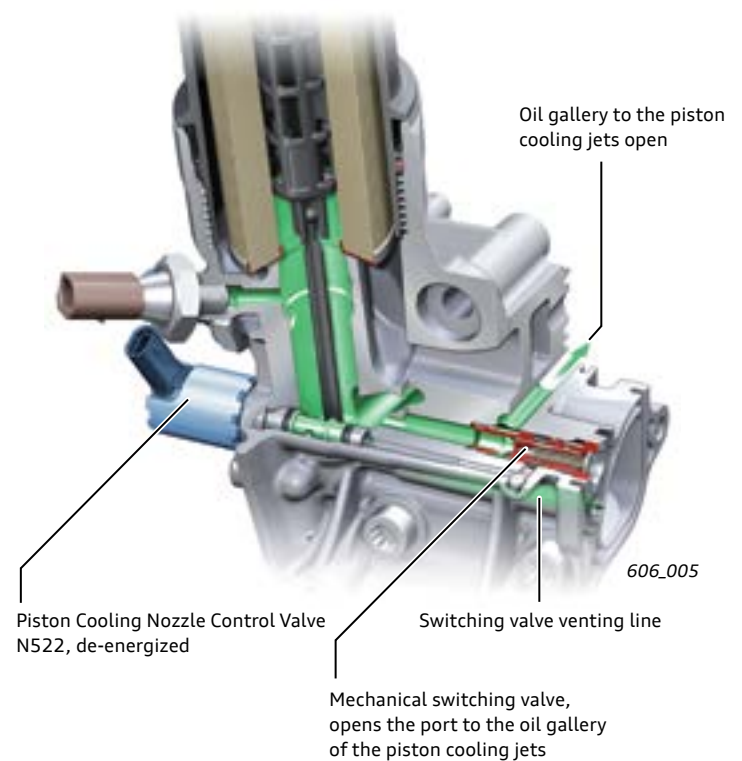

Function monitoring

When the piston cooling jets are switched on, the contact in Oil Pressure Switch Level 3 F447 closes. The switch is located at the end of the oil gallery for the piston cooling jets (see page 30, Fig. 606_003).

The following faults can be detected by the oil pressure switch:

- ▶ No oil pressure is present at the piston cooling jets despite being requested
- ▶ Faulty oil pressure switch
- ▶ Oil pressure is present despite deactivation of piston cooling jets

The following electrical faults can be detected in the control valve for the piston cooling jets:

- ▶ Open circuit; piston cooling jets are always on
- ▶ Short circuit to ground; piston cooling is off
- ▶ Short circuit to +; piston cooling is always on

Faults resulting in loss of piston cooling lead to the following emergency running reactions:

- ▶ Torque and engine speed are limited by the ECM
- ▶ The regulated oil pump has no low oil pressure stage
- ▶ A message indicating that the engine speed is limited to 4000 rpm is displayed in the DIS, a single acoustic signal sounds and the EPC lamp lights up

Cooling system

System overview

The cooling system is adapted to match the vehicle specification and engine type.

A distinction is made between longitudinal and transverse mounting, transmission version, and whether or not the vehicle is equipped with an auxiliary heater. Vehicles sold in the North American region will not have auxiliary heaters.

Coolant circulation

The 1.8l TFSI is given here as an example. It is in the longitudinal mounted version with a manual transmission.

Numbers from the key on page 35 have been added to the labels in the diagram.

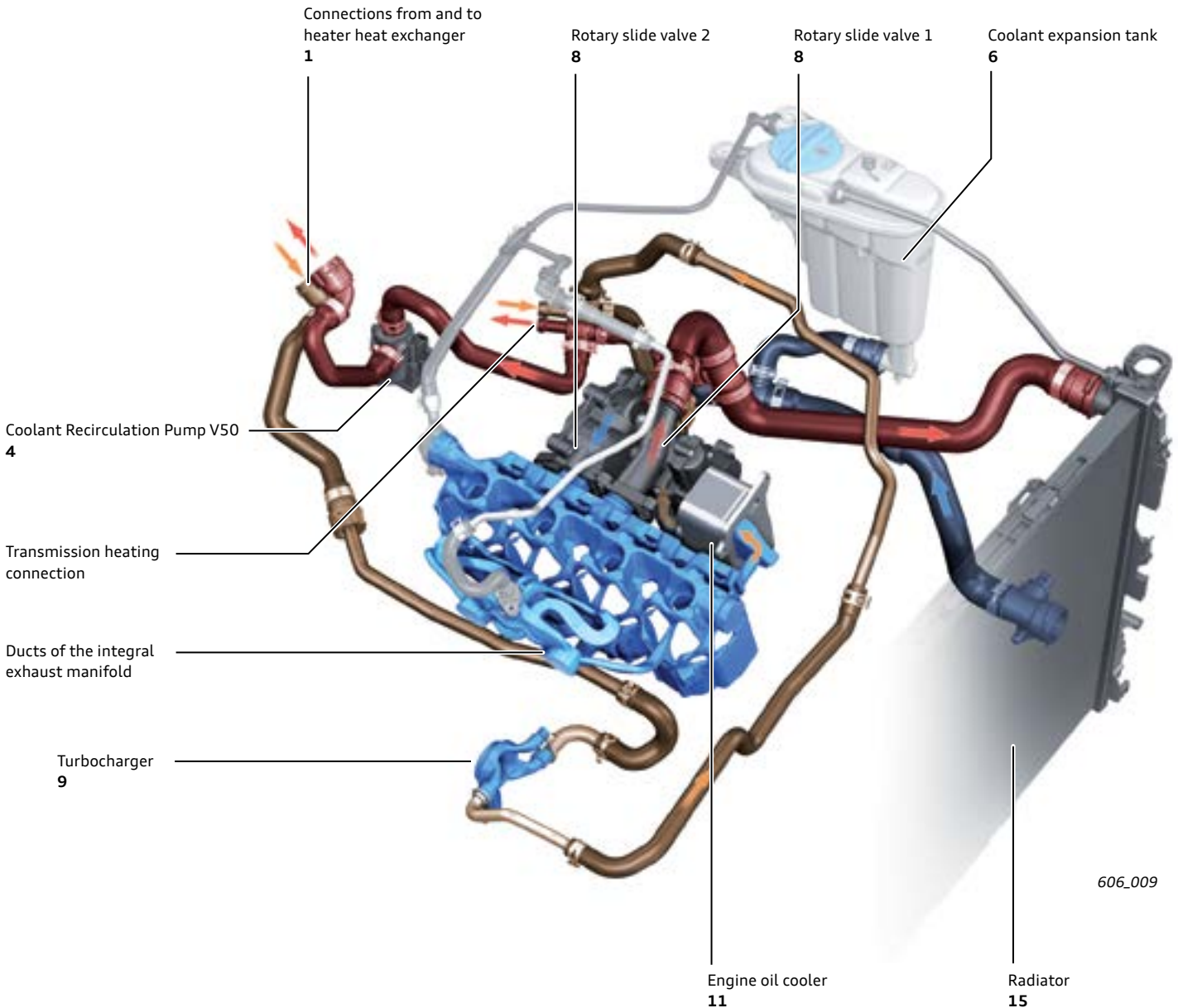

Note

Auxiliary heaters are not available in the North American market.



Note

For vehicle-specific terminal diagrams, refer to the applicable repair information.

1.8l TFSI longitudinal mounted engine with manual transmission*

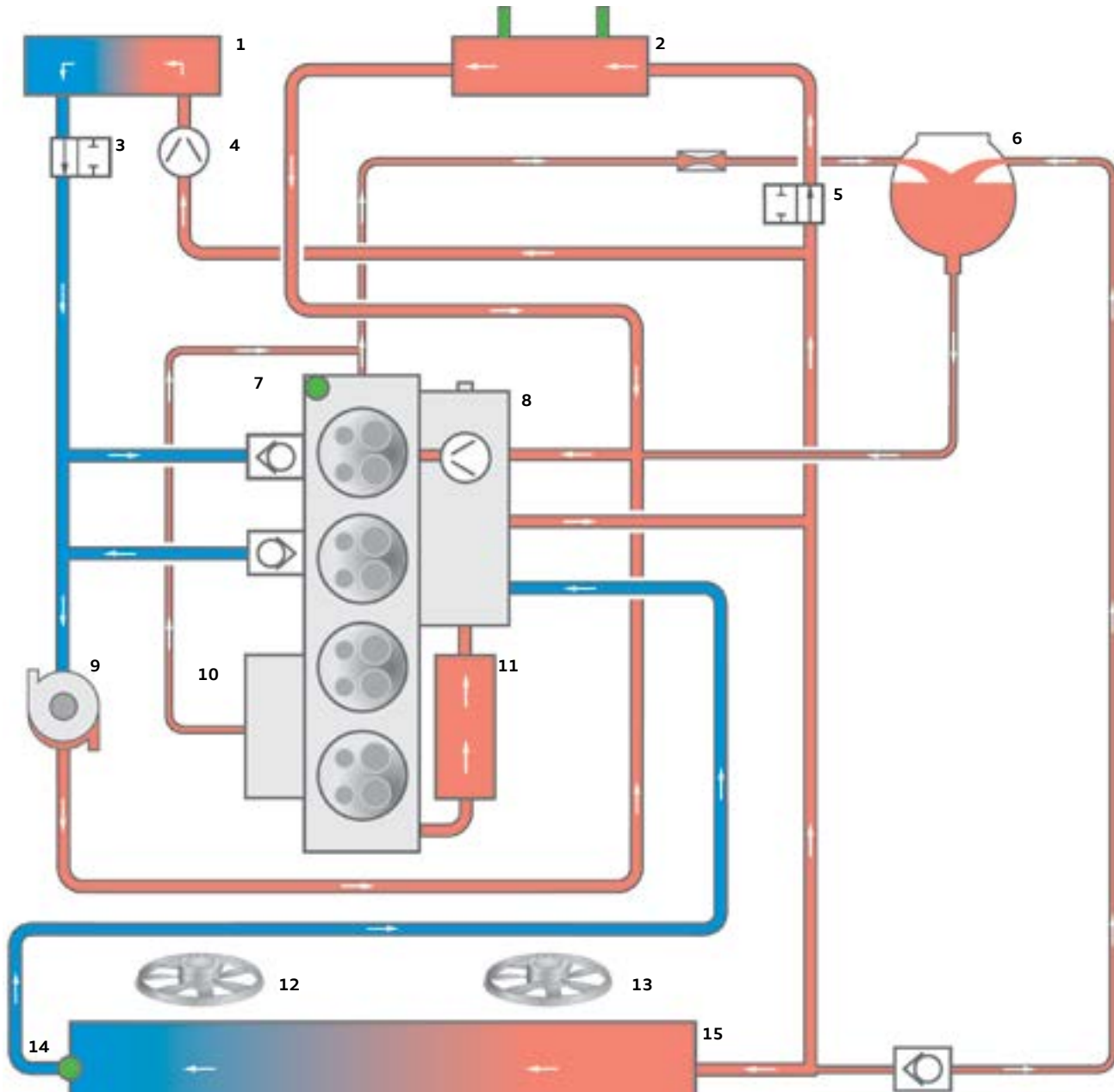

606_023

- █ Cooled coolant
- █ Heated coolant
- █ ATF

Key:

- | | |
|--|---|
| 1 Passenger compartment heat exchanger | 9 Exhaust turbocharger |
| 2 Transmission gear oil cooler | 10 Integral exhaust manifold |
| 3 Climatronic Coolant Shut-off Valve N422 activated | 11 Engine oil cooler (heat exchanger) |
| 4 Coolant Recirculation Pump V50 | 12 Coolant Fan V7 |
| 5 Transmission Coolant Valve N488 | 13 Coolant Fan 2 V177 |
| 6 Coolant expansion tank | 14 Engine Coolant Temperature Sensor on Radiator G83 |
| 7 Engine Coolant Temperature Sensor G62 | 15 Radiator |
| 8 Engine Temperature Control Actuator N493
(rotary slide valves 1 and 2) | |

* This configuration will be introduced in later Audi models and does not apply to the 2015 Audi A3.

Innovative Thermal Management (ITM)

The complete coolant circuit was revised during development of the engine. The main emphasis was on rapid engine heating, reduction in fuel consumption by rapid and thermodynamically optimized engine temperature regulation, as well as heating of the vehicle interior when required.

The two key components of the innovative thermal management system are the exhaust manifold integrated into the cylinder head (see "Cylinder head") and Engine Temperature Control Actuator N493 described below. It is installed as a module on the cooling side of the engine, together with the coolant pump.

Coolant temperature at ambient temperature 68 °F (20 °C)

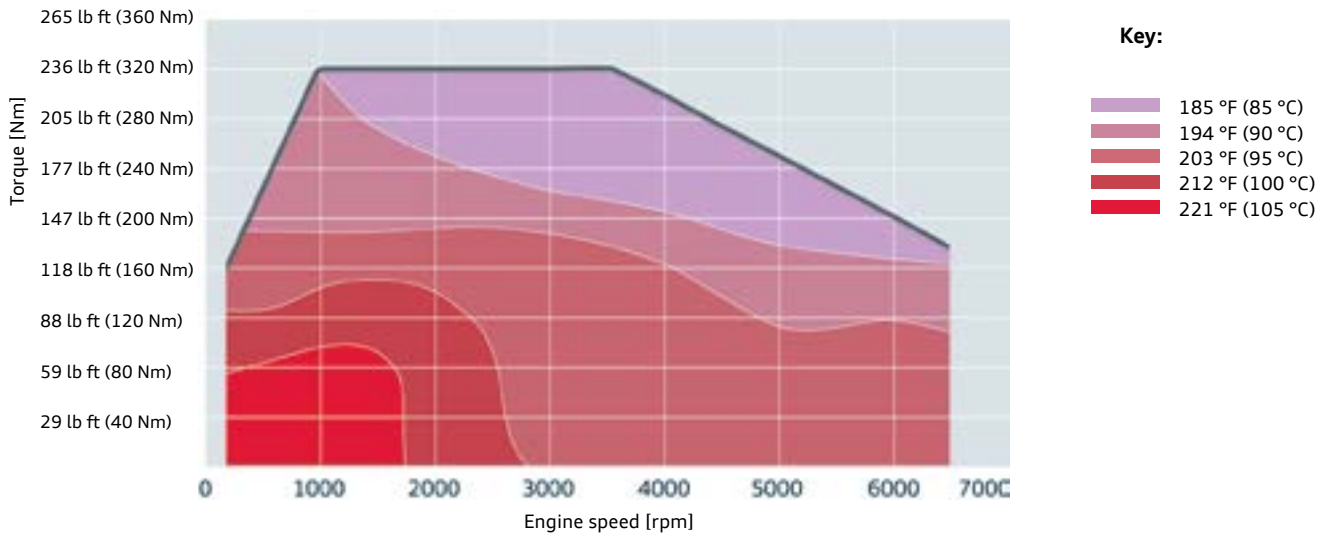

606_040

Engine Temperature Control Actuator with rotary slide valve module and coolant pump

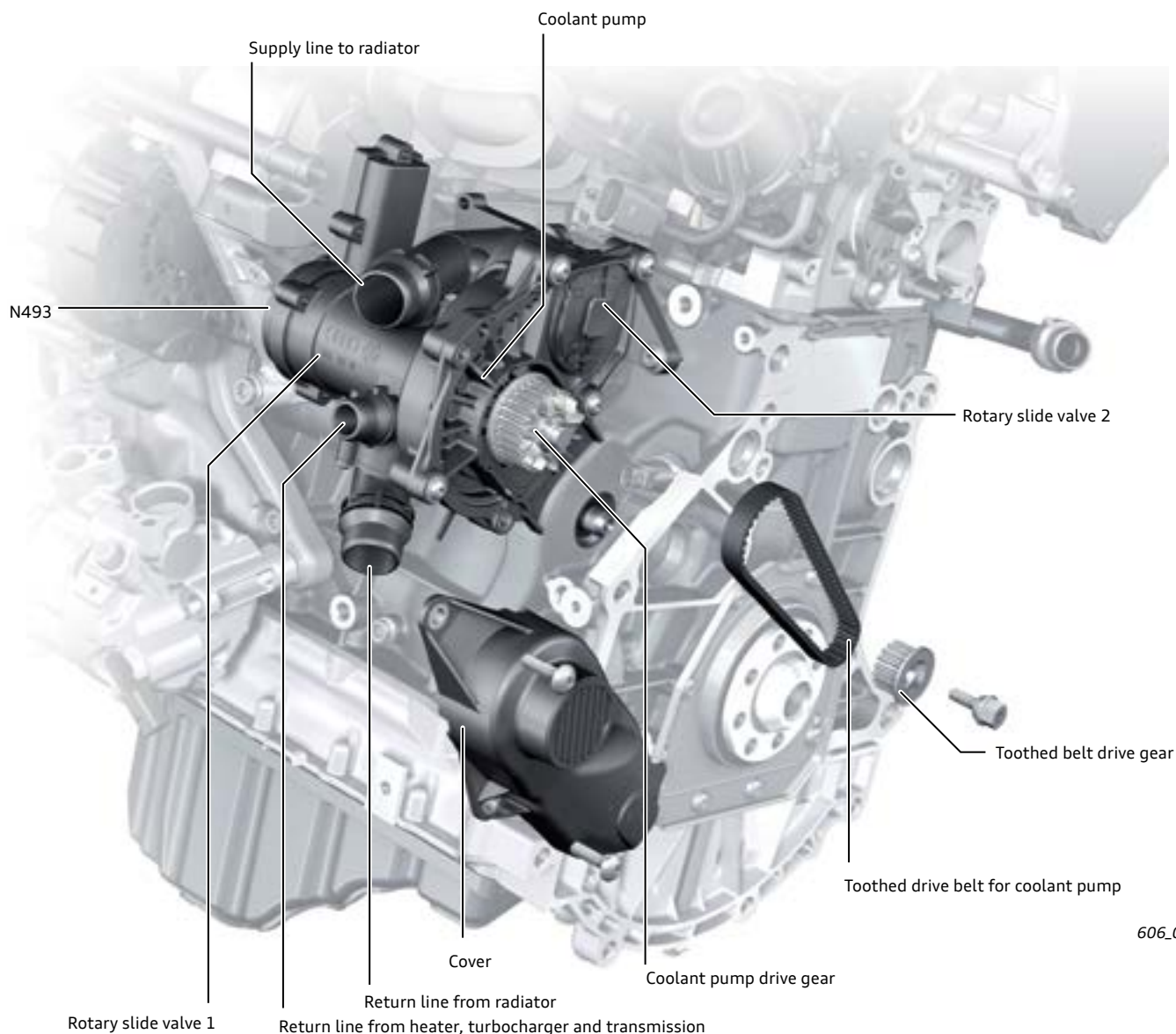

eMedia



Animation showing the ITM system and the function of the rotary slide.

Engine Temperature Control Actuator N493 (rotary slide valve)

Engine Temperature Control Actuator N493 is identical for longitudinally and transversely mounted engines. It regulates coolant flow by means of two mechanically coupled rotary slide valves. The angular position of the rotary slide valves is regulated according to various maps stored in the ECM.

Various switching positions can be implemented by configuring the rotary slide valves accordingly. This allows rapid heating of the engine, which, in turn, results in lower friction and improved fuel economy. In addition, variable engine operating temperatures between 185 °F - 225 °F (85 °C - 107 °C) are possible.

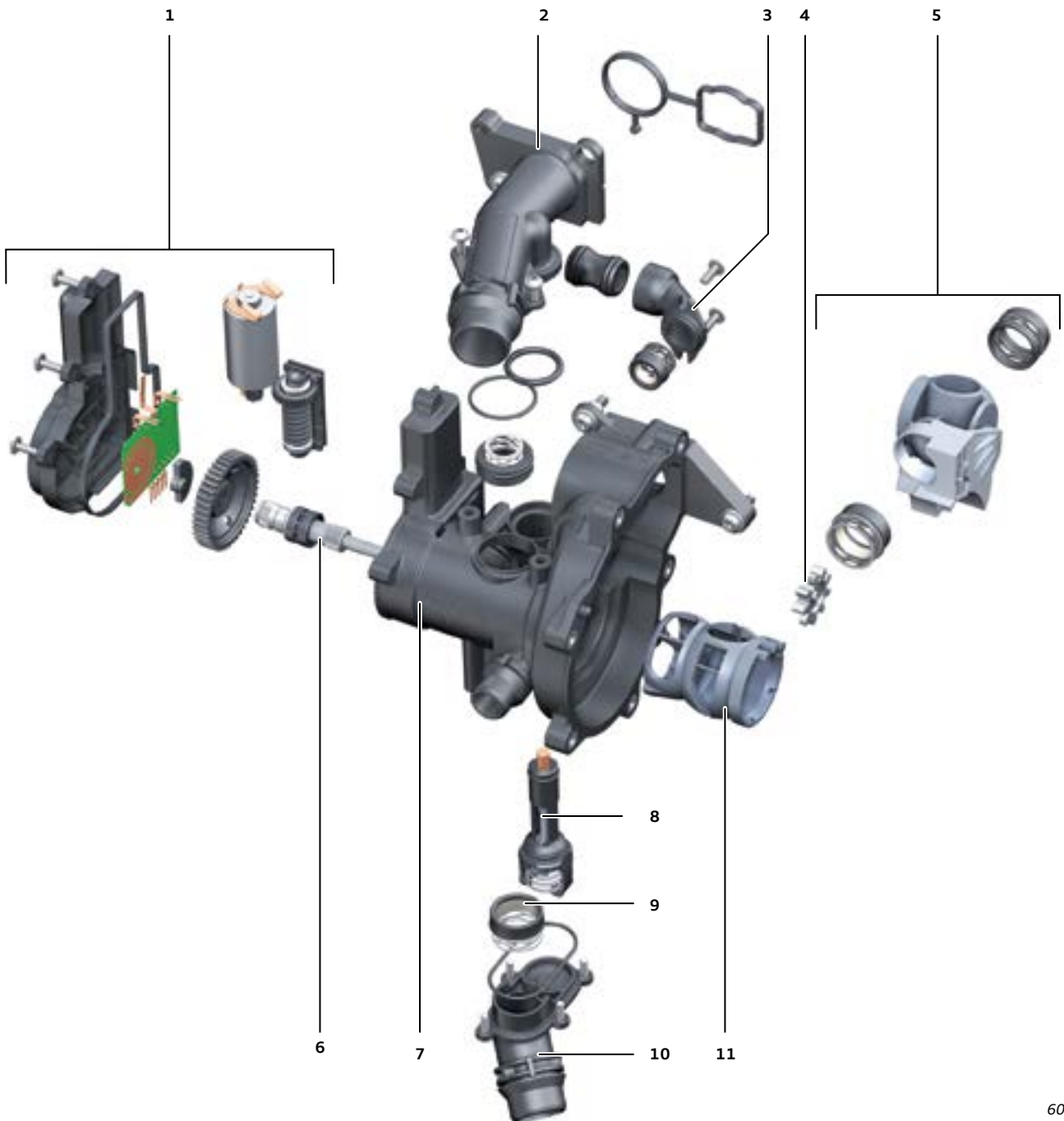

Key:

- | | | | |
|---|--|----|---|
| 1 | N493 with sender | 6 | Shaft for rotary slide valve 1 |
| 2 | Connecting piece for radiator supply line | 7 | Rotary slide valve housing |
| 3 | Connecting piece to lube oil cooler connection | 8 | Expanding element thermostat (fail-safe thermostat) |
| 4 | Idler gear | 9 | Sealing package |
| 5 | Rotary slide valve 2 | 10 | Connecting piece for return line from radiator |
| | | 11 | Rotary slide valve 1 |

606_036

Function of Engine Temperature Control Actuator N493

A DC electric motor drives the rotary slide valve. It is activated by a PWM signal (12V) from the Engine Control Module. The activation frequency is 1000 Hz. The activation signal is new. It is a digital signal with a configuration similar to that of a CAN signal.

The motor is activated until rotary slide valve is in the position specified by the ECM. A positive activation signal causes the rotary slide valve to rotate in the "open" direction. This can be observed in the MVBs. The motor drives rotary slide valve 1 via a high reduction ratio worm gear. It controls the coolant flow in the engine oil cooler, cylinder head and the main radiator. The transmission cooler, turbocharger and heater return lines are unregulated.

The warmer the engine, the further the rotary slide valve rotates. This causes various channels to open into variable cross-sections.

Rotary slide valve 2 is connected to rotary slide valve 1 via a lantern gear. The gear is designed in such a way that rotary slide valve 2 engages and disengages in defined angular positions of rotary slide valve 1. Rotary slide valve 2 (which opens the coolant flow through the cylinder block) begins to rotate when rotary slide valve 1 is in an angular position of approx. 145°. Rotary slide valve 1 disengages again in an angular position of approx. 85°. In this position, rotary slide valve 2 has completed its maximum rotation and the cylinder block cooling circuit is fully open. The movements of the rotary slide valve are limited by mechanical stops.

To determine the exact position of the rotary slide valve and to detect malfunctioning, a rotation angle sensor is mounted on the rotary slide valve control board. This sensor supplies a Single Edge Nibble Transmission (SENT) data protocol signal to the ECM. This type of signal can, in conjunction with the appropriate sensors, be used for digital data transfer as a replacement for analog interfaces. The position of rotary slide valve 1 can be seen in the MVBs.

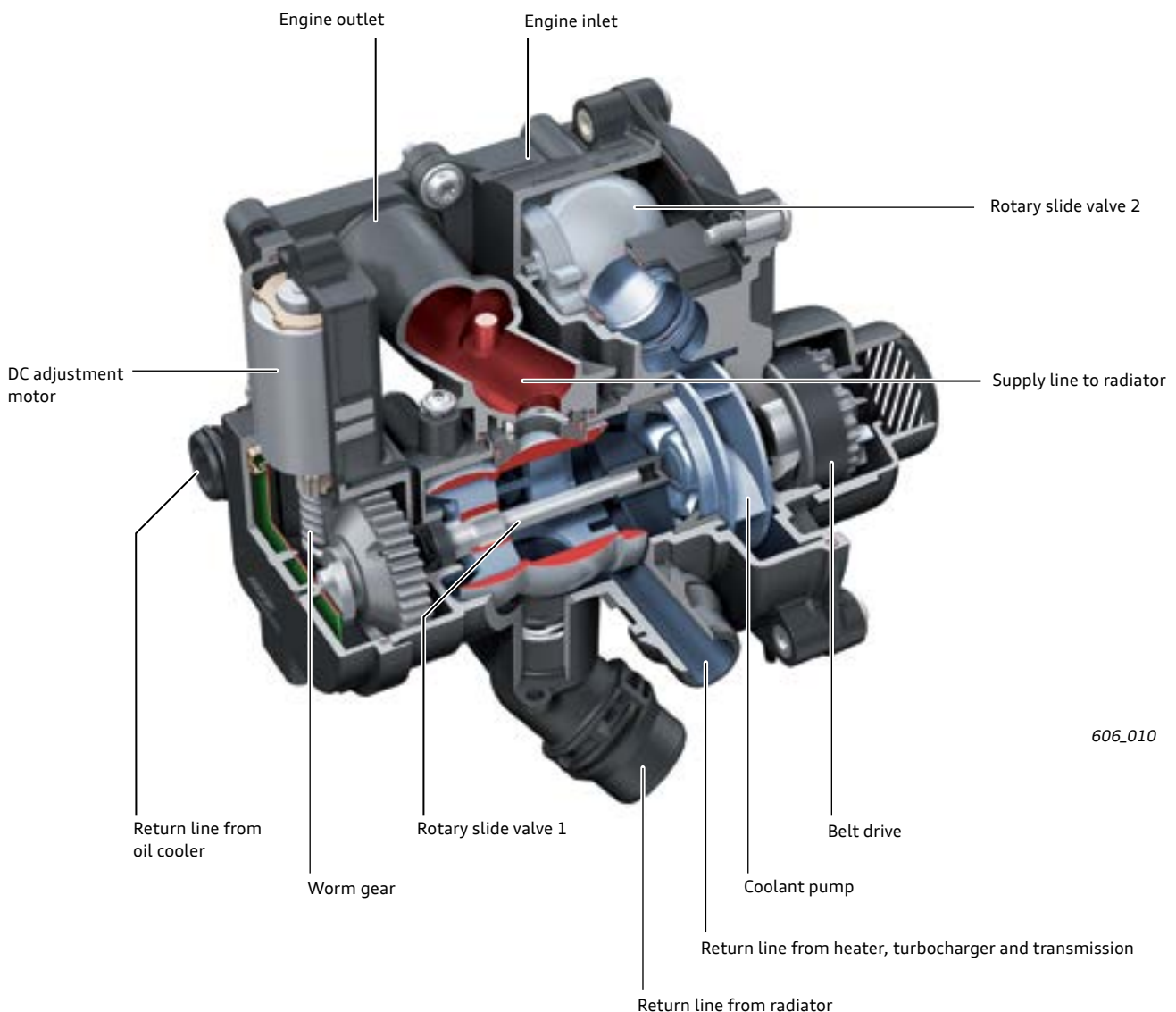

Engine warm-up and operation is divided into three phases of regulation

Adjustment angle

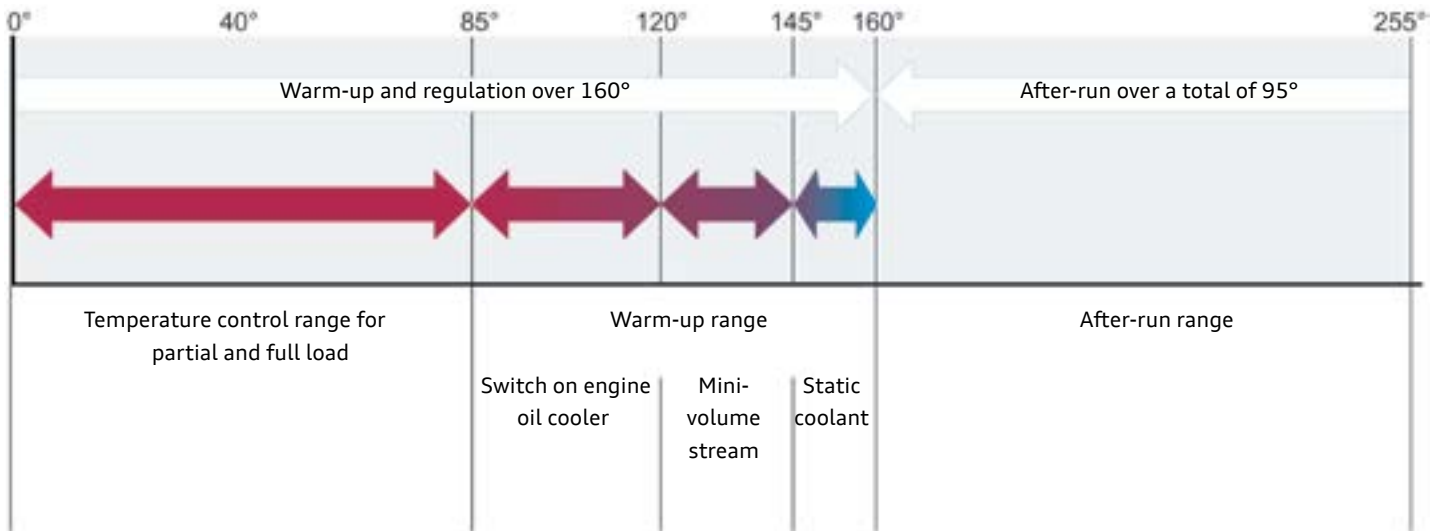

s522_107

The following pages describe the engine temperature regulation from the warm-up range, the temperature control range and finally to the after-run range. This is a highly simplified representation and does not include the electrical drive of the Engine Temperature Control Actuator N493 or the main water pump drive.

Temperature regulation sequence

During warm-up, the engine runs through three phases:

- ▶ Static coolant
- ▶ Mini-volume stream
- ▶ Enable engine oil cooler

The different phases are accomplished through the positions of the rotary valves. The objective is to use the energy generated by the fuel combustion to heat the engine as much as possible. However, if passenger compartment heating is required during the "static coolant" phase, heat energy is provided to the interior.

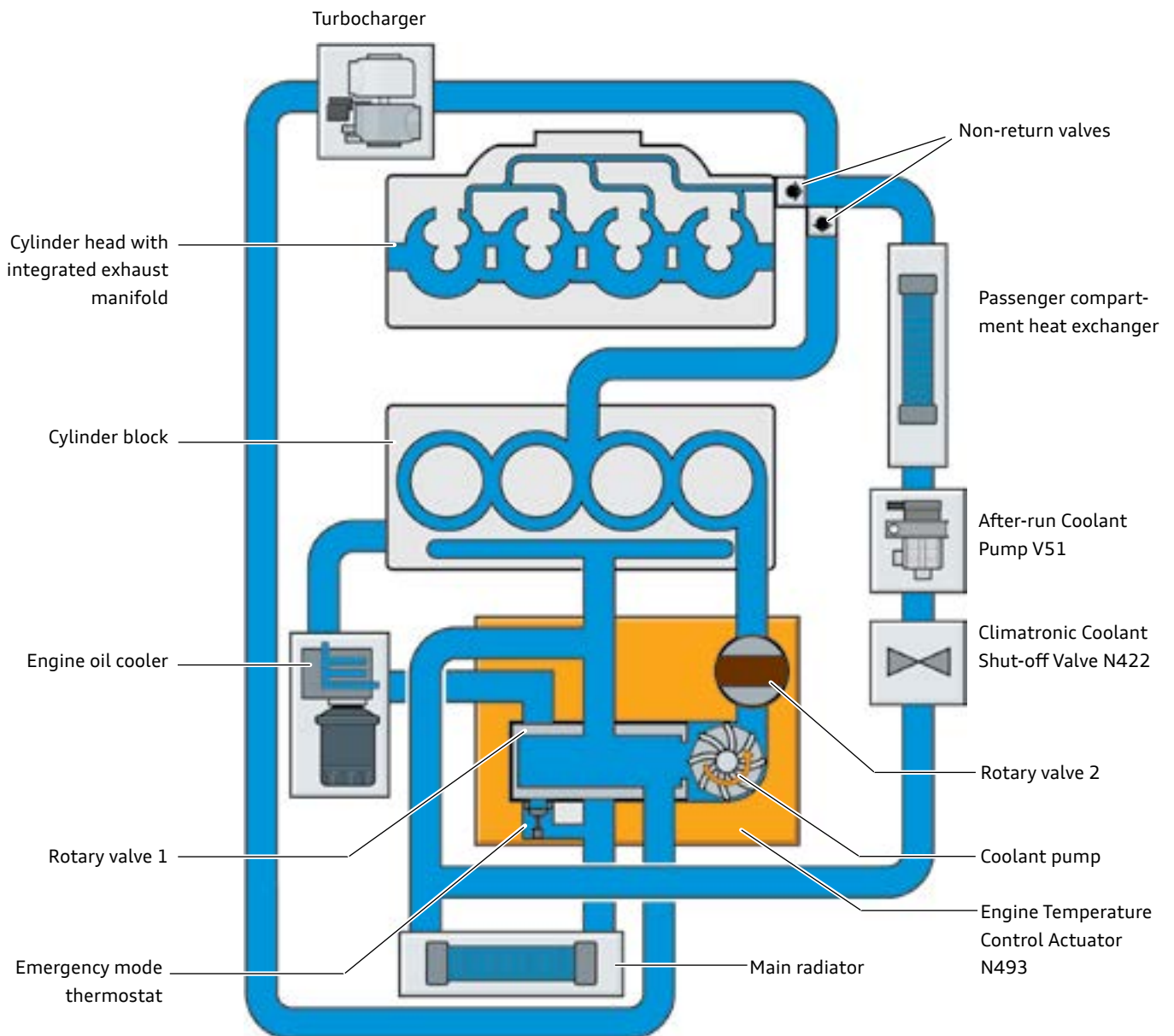

s522_092

Warm-up with static coolant

To keep the heat from the fuel combustion in the engine, Rotary valve 2 is closed. This interrupts the coolant flow from the engine coolant pump to the cylinder block. Rotary valve 1 blocks return from the engine oil cooler and the return from the main radiator.

Climatronic Coolant Shut-off Valve N422 interrupts the coolant flow to the passenger compartment heat exchanger and Coolant After-run Pump V51 is not activated.

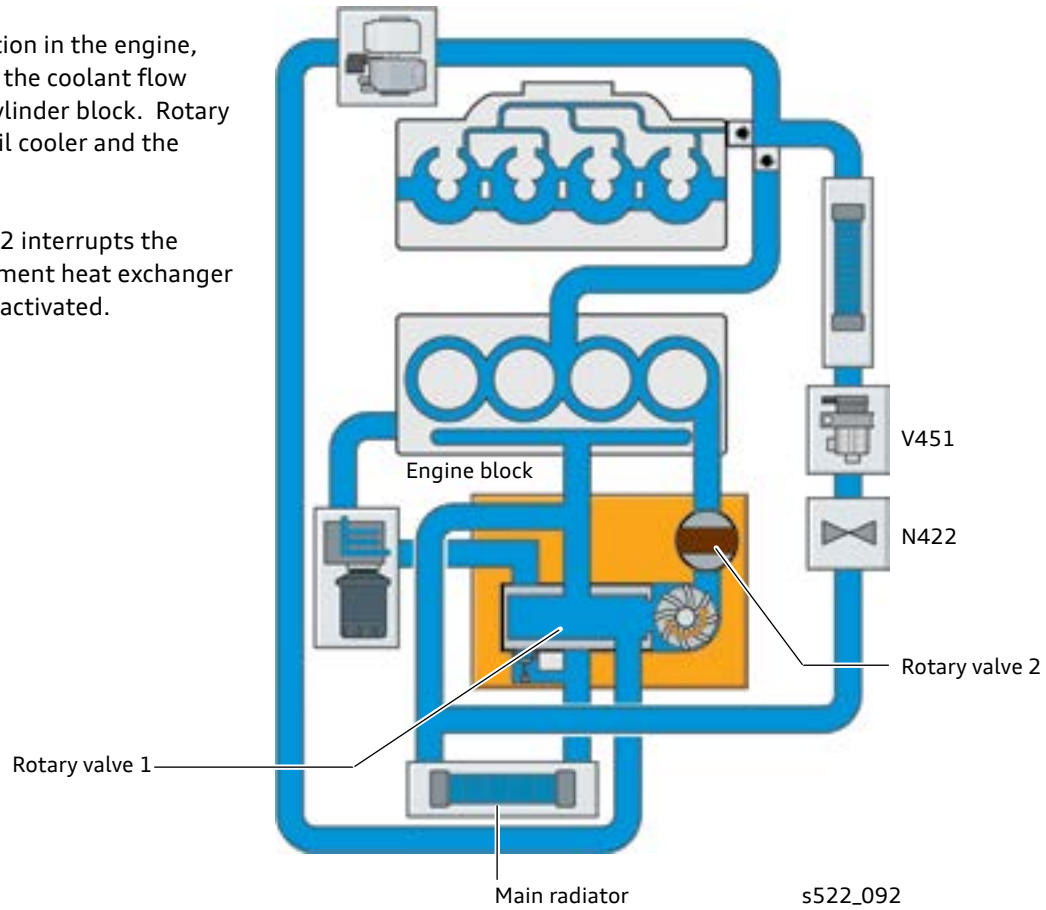

Warm-up with mini-volume flow

This control phase in the warm-up range protects the cylinder head and the turbocharger from overheating from the static coolant in the exhaust manifold.

At a Rotary valve 1 angle position of 145°, Rotary valve 2 is engaged and begins to open. A small coolant flow begins through the cylinder block, the cylinder head and the turbocharger returning back to the rotary valve module and coolant pump.

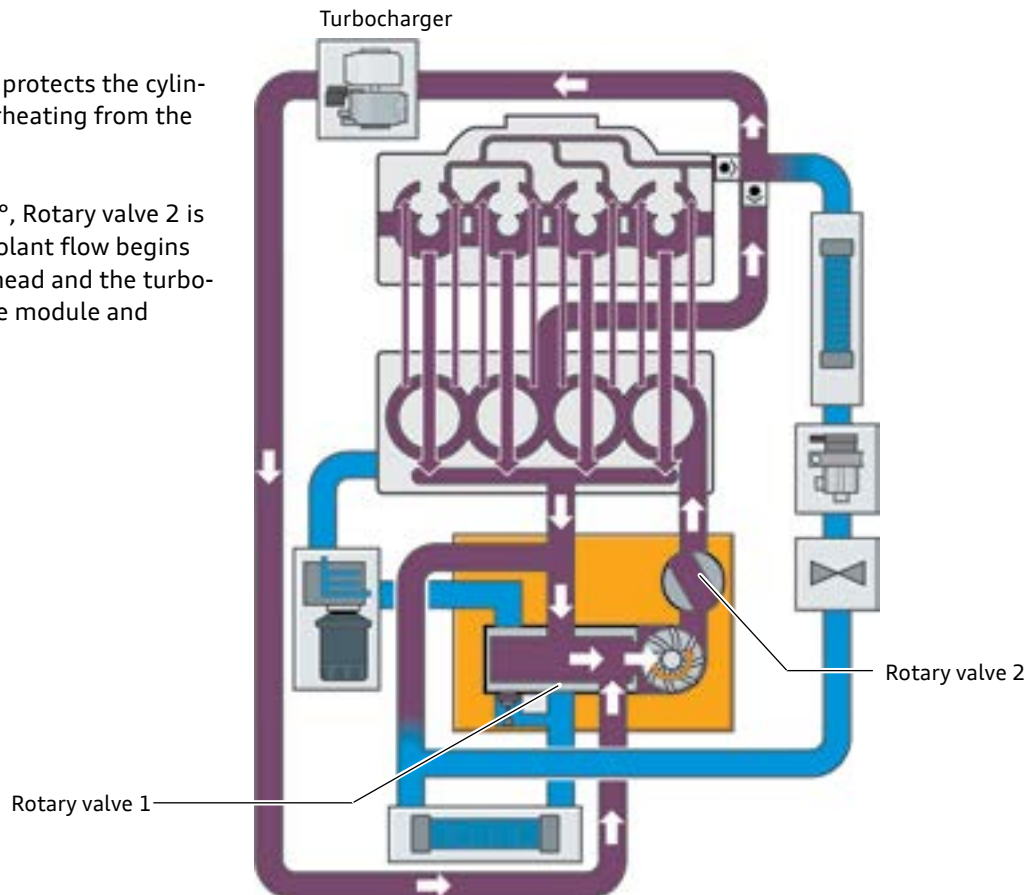

Warm-up with mini-volume flow and heating in the vehicle interior

If heating is required in the passenger compartment during this phase, N422 opens and After-run Coolant Pump V51 starts delivery. Rotary valve 2 temporarily interrupts the coolant flow to the cylinder block.

The coolant is directed through the cylinder head, turbo-charger and heat exchanger. This, however, causes the warm-up phase of the engine to take longer.

N422 and V51 are also always activated to comply with requirements in the subsequent control ranges. The coolant flow to the engine block is reduced or blocked by rotary valve 2 as required.

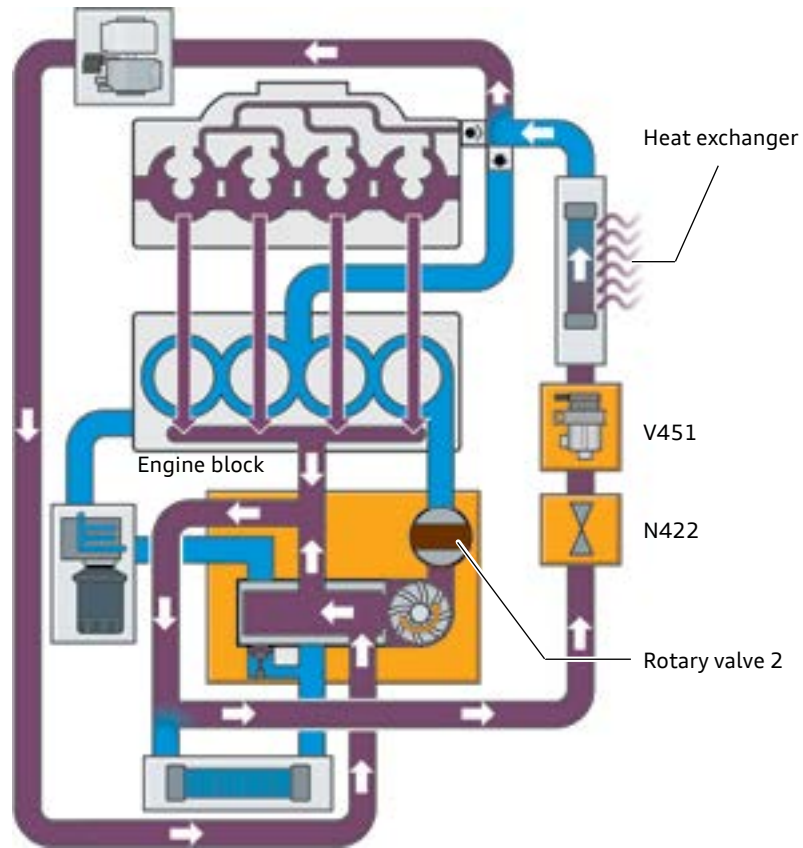

s522_094

Warm-up with map-controlled engine active

In this stage, the engine oil cooler is enabled during the warm-up phase of the engine. Rotary valve 1 moves to a 120° angle position opening the passage to the oil cooler. Because Rotary valve 2 is still engaged, it also turns more and enlarges the coolant flow through the cylinder block. A large amount of heat distribution occurs in the engine block and excess heat is discharged via the oil cooler.

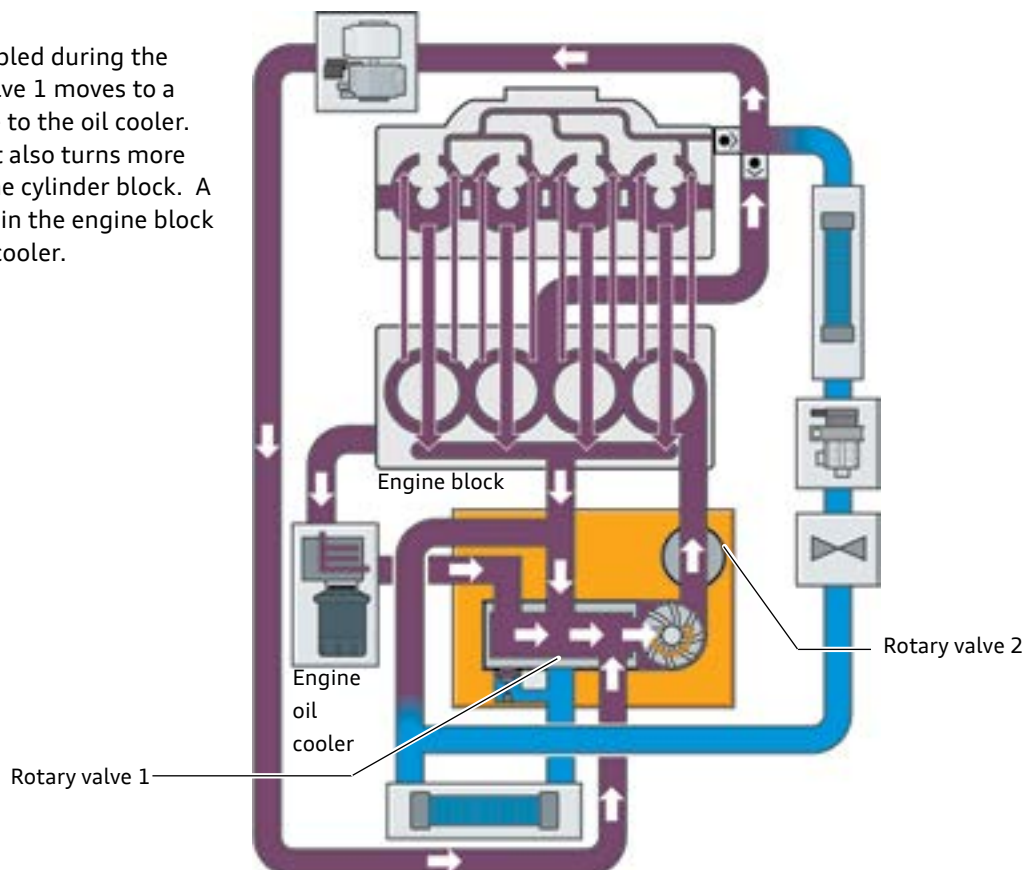

s522_095

Temperature control range

The innovative thermal management moves seamlessly from the warm-up range to the temperature control range. Here, rotary valve module regulation is dynamic and depends on the engine load.

To conduct excess heat away, the connection to the main radiator from the rotary valve module is opened. To do this, positions rotary valve 1 in an angle position of 0° and 85° , depending on how much heat has to be conducted away. At a rotary valve 1 angle position of 0° the connection to the main water cooler is fully opened.

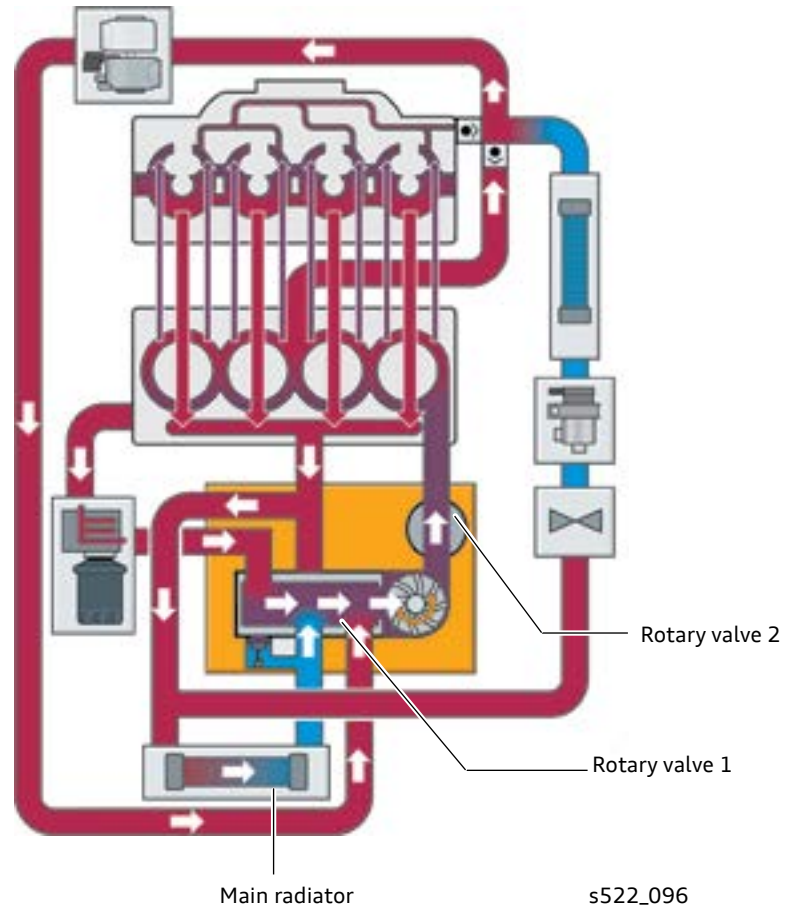

If the engine is running at a lower load and speed (partial load range), the thermal management adjusts the coolant temperature to 225°F (107°C). Since the full cooling power is not required, rotary valve 1 temporarily closes the connection to the main radiator. If the temperature rises above this threshold value, the connection to the main radiator is opened again. Constant opening and closing is necessary to keep the temperature as much as possible at a constant 225°F (107°C).

When load and engine speed increase, coolant temperature is reduced to 185°F (85°C) (full load range) by first completely opening the connection to the main radiator.

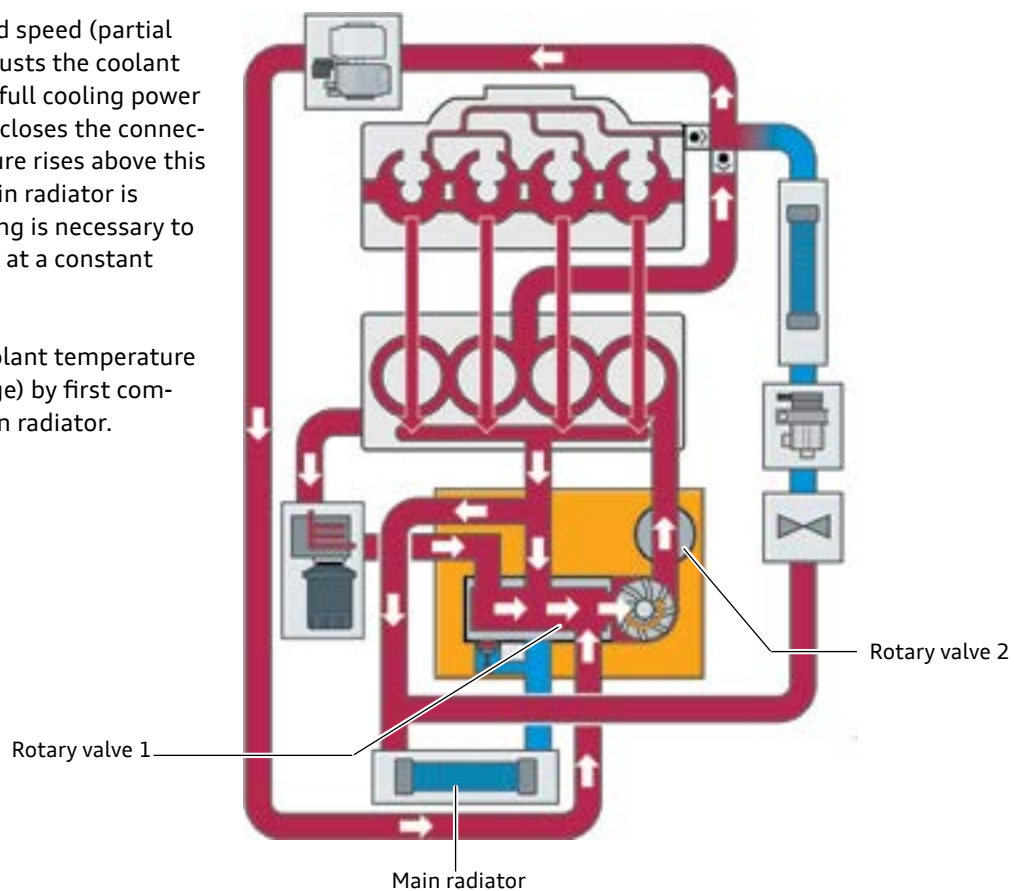

After-run range when switching off the engine

To prevent the coolant from boiling in the cylinder head and in the turbocharger when the engine is switched off, the ECM initiates an after-run function. It can be active for up to 15 minutes after the engine is switched off.

During the after-run function, Rotary valve 1 of N493 is positioned at an angle between 160 degrees and 255 degrees. The greater the after-run requirement, the higher the angle position. At 255 degrees of opening angle, the passage to the return line of the main radiator is fully open so maximum heat is dissipated.

Rotary valve 2 is in the after-run position and not engaged with Rotary valve 1. V51 circulates coolant through two sub-streams in the coolant circuit.

One sub-stream flows over the cylinder head and back to V51. A second sub-stream flows via the turbocharger through Rotary valve 1 to the main radiator and also to After-run Coolant Pump V51.

The cylinder block is not supplied with coolant in the run-on position.

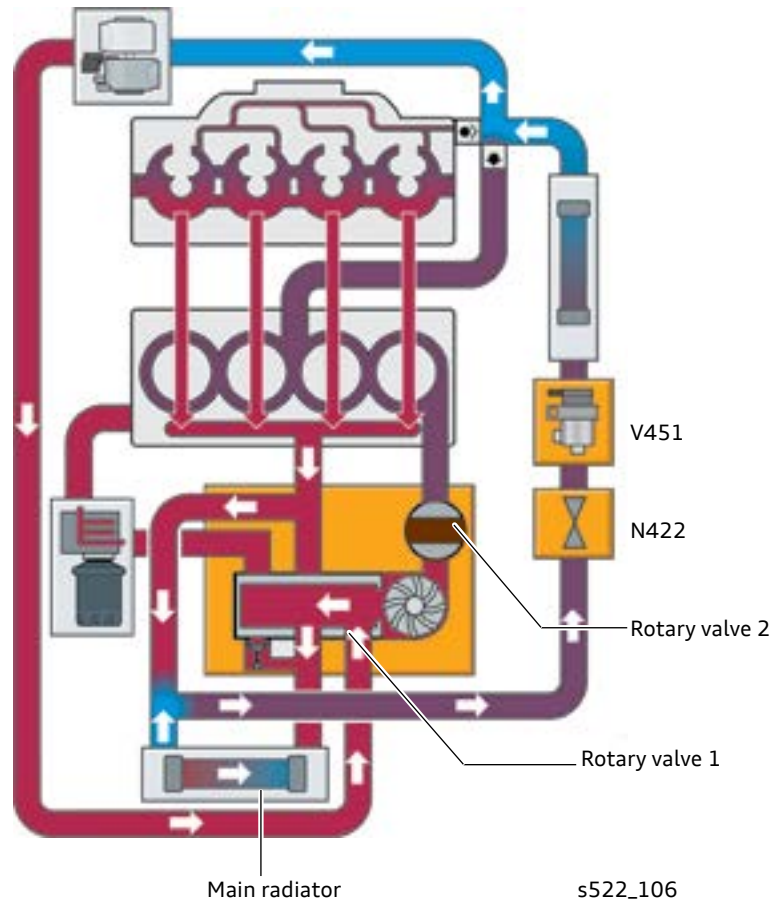

Emergency running mode strategy

If the coolant temperature in N493 exceeds 235 °F (113 °C), the emergency thermostat opens a bypass to the main radiator. This allows the driver to continue driving the vehicle to a limited extent if N493 is defective.

If the ECM doesn't receive feedback from N493, it moves Rotary valve 1 to a maximum engine cooling position regardless of engine load and operating temperature.

If N493 should fail, for example, the electric motor fails or the rotary valve drive should jam, further measures are initiated:

- ▶ A fault message is displayed in the instrument cluster and at the same time engine speed is limited to 4000 rpm. A warning tone is issued and the EPC is illuminated.
- ▶ The actual engine coolant temperature is also displayed in the instrument cluster.
- ▶ Climatronic Coolant Shut-off Valve N422 is opened.
- ▶ After-run Coolant Pump V51 is activated to ensure cylinder head cooling.
- ▶ A DTC is logged in the Engine Control Module.

If the rotary valve position sensor signal is implausible or the sensor fails, the ECM activates Rotary valve 1 to a maximum cooling position as a failsafe.

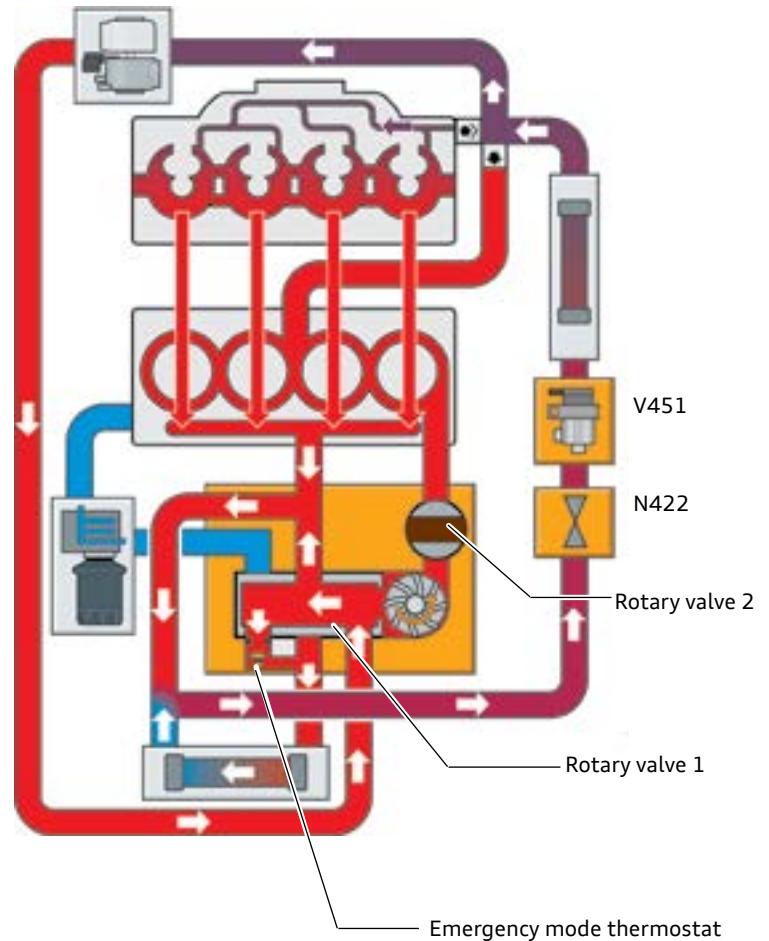

s522_097

Vehicles with DSG transmissions

On vehicles with DSG transmissions, the coolant circuit is expanded to include a transmission heat exchanger and Transmission Coolant Valve N488.

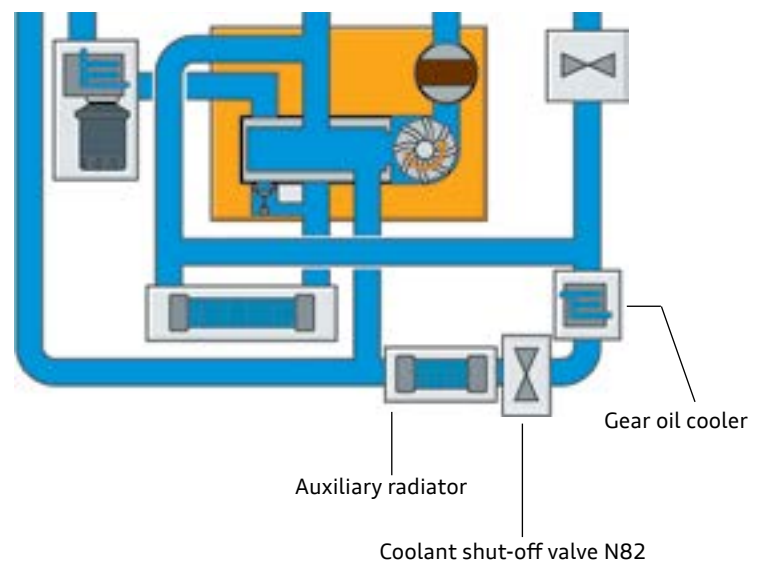

s522_101

Functional diagram of Engine Temperature Control Actuator N493

Connections

- ① Sensor ground (connection in engine wiring harness)
- ② Sensor signal
- ③ Sensor + (5 V connection in engine wiring loom)
- ④ Actuator -
- ⑤ Actuator +

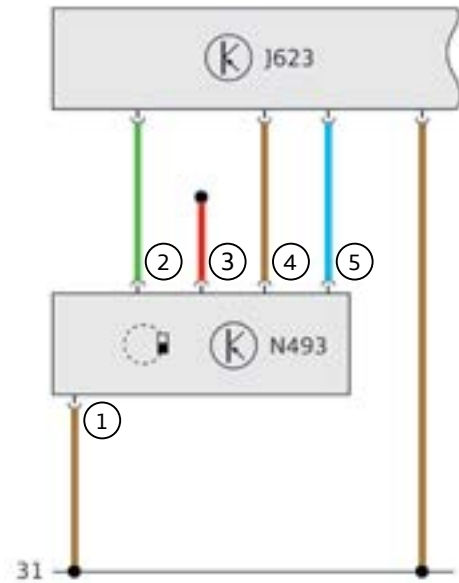

606_021

Transmission Coolant Valve N488

N488 controls the flow of warm coolant from the engine to the transmission gear oil cooler.

When required, the solenoid valve is activated by the ECM.

It is held open by mechanical spring force when not activated and closes when the engine is started. The coolant flow to the transmission opens at a coolant temperature of 176 °F (80 °C) and closes again at 194 °F (90 °C). This helps the manual transmission to attain its optimal friction temperature.

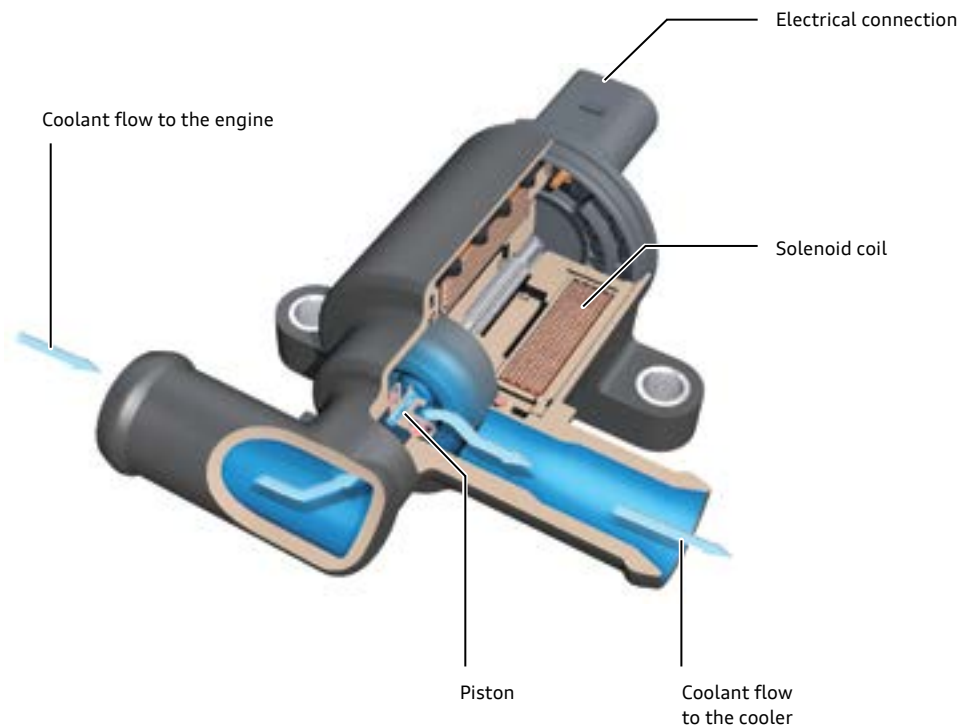

606_022

Coolant Recirculation Pump V50

This pump is used as a circulation pump for the passenger compartment heat exchanger in vehicles with longitudinally mounted engines. It is activated by Climatronic Control Module J255 via a PMW signal. It is diagnosed through J255.

Function

Coolant Recirculation Pump V50 is activated when the ignition is switched on depending on the coolant temperature and the desired interior temperature setting of Climatronic Control Module J255.

When V50 is running, coolant is circulated between the engine and the passenger compartment heat exchanger.



Coolant Recirculation Pump V50

606_056

Climatronic Coolant Shut-off Valve N422

N422 is installed on longitudinally mounted engines. The valve permits or prevents coolant flow to the passenger compartment heat exchanger. See page 35, figure 606_023.

Function

Climatronic Coolant Shut-off Valve N422 is identical to Transmission Coolant Shut-off Valve N488 (see previous page). It is open (allowing coolant flow) when it is not energized and closes (preventing coolant flow) when current is applied. It is opened by spring force and closes when the engine is started.

The valve opens when the heating, run-on cooling and start-stop functions are activated. N422 is controlled by Climatronic Control Module J255 and requires adaptation using the VAS Scan Tool.

Coolant After-run Pump V51

V51 is installed on vehicles with transversely mounted engines. It is identical to Coolant Recirculation Pump V50 used in vehicles with longitudinally mounted engines. It is activated by the ECM with a PWM signal after receiving a request from Climatronic Control Module J255.

V51 also assists the engine coolant pump to increase coolant flow through the passenger compartment heat exchanger at defined engine speeds thus providing higher heating output.

It also helps reduce turbocharger temperature more quickly which helps extend engine oil life.

Coolant Shut-off Valve N82

Coolant Shut-off Valve N82 is activated by the Engine Control Module.

Depending on the requested temperature in the passenger compartment, N82 shuts off the coolant flow through the passenger compartment heat exchanger. This is done for example, to heat up the engine.

Air supply and charging

System overview

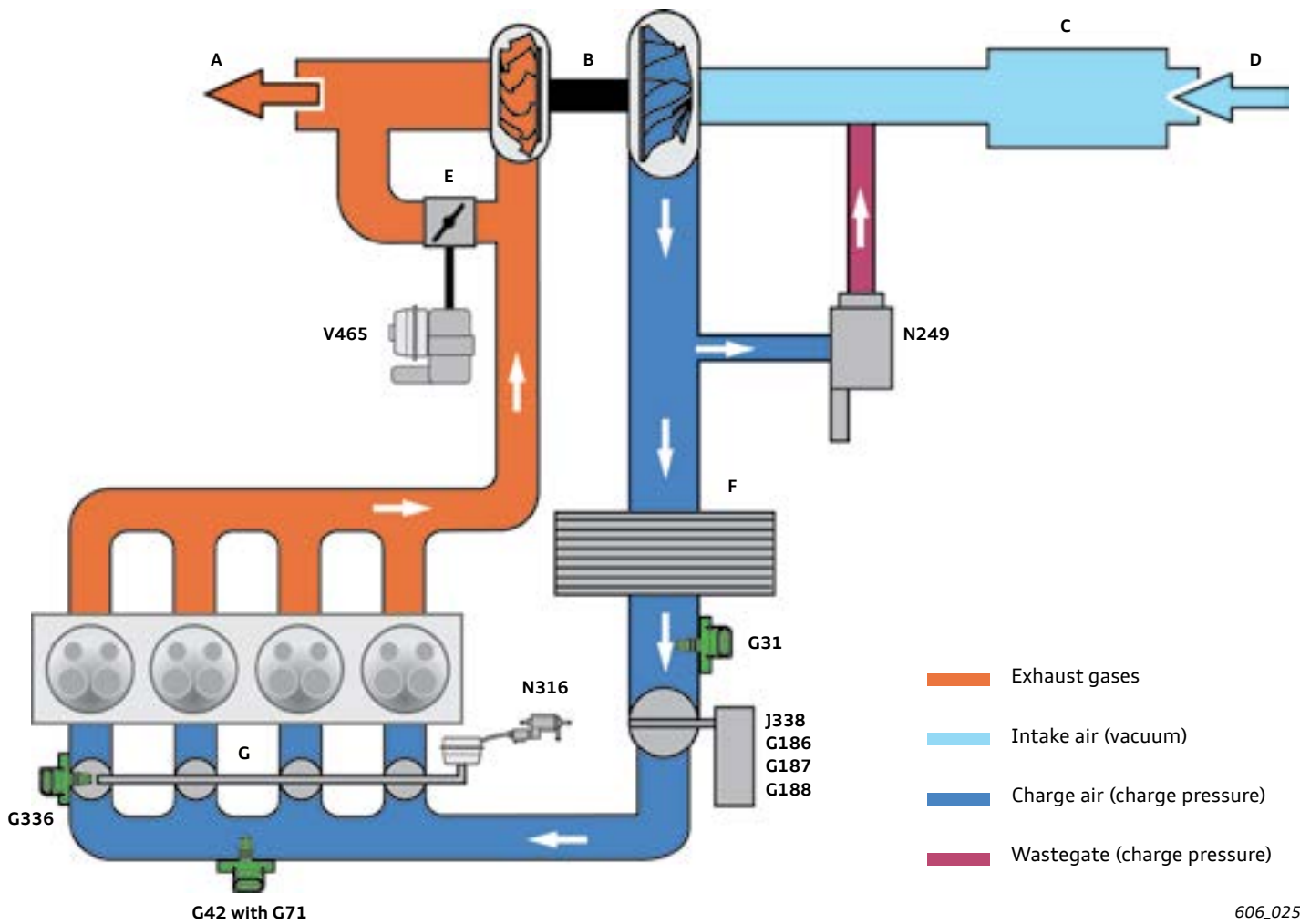

Key:

- A Exhaust flow
- B Exhaust turbocharger
- C Air filter
- D Fresh air flow
- E Wastegate valve
- F Charge air cooler
- G Intake manifold flaps

- G31 Charge Air Pressure Sensor
- G42 Intake Air Temperature Sensor
- G71 Manifold Absolute Pressure Sensor
- G186 EPC Throttle Drive
- G187 EPC Throttle Drive Angle Sensor 1
- G188 EPC Throttle Drive Angle Sensor 2
- G336 Intake Manifold Runner Position Sensor
- J338 Throttle Valve Control Module
- N249 Turbocharger Recirculation Valve
- N316 Intake Manifold Runner Control Valve
- V465 Charge Pressure Actuator



Note

The Charge Pressure Actuator V465 must be replaced after removing the lock nut from the linkage. After replacement, the charge pressure actuator must be adapted using the Scan Tool.

Air routing system for transversely mounted engines

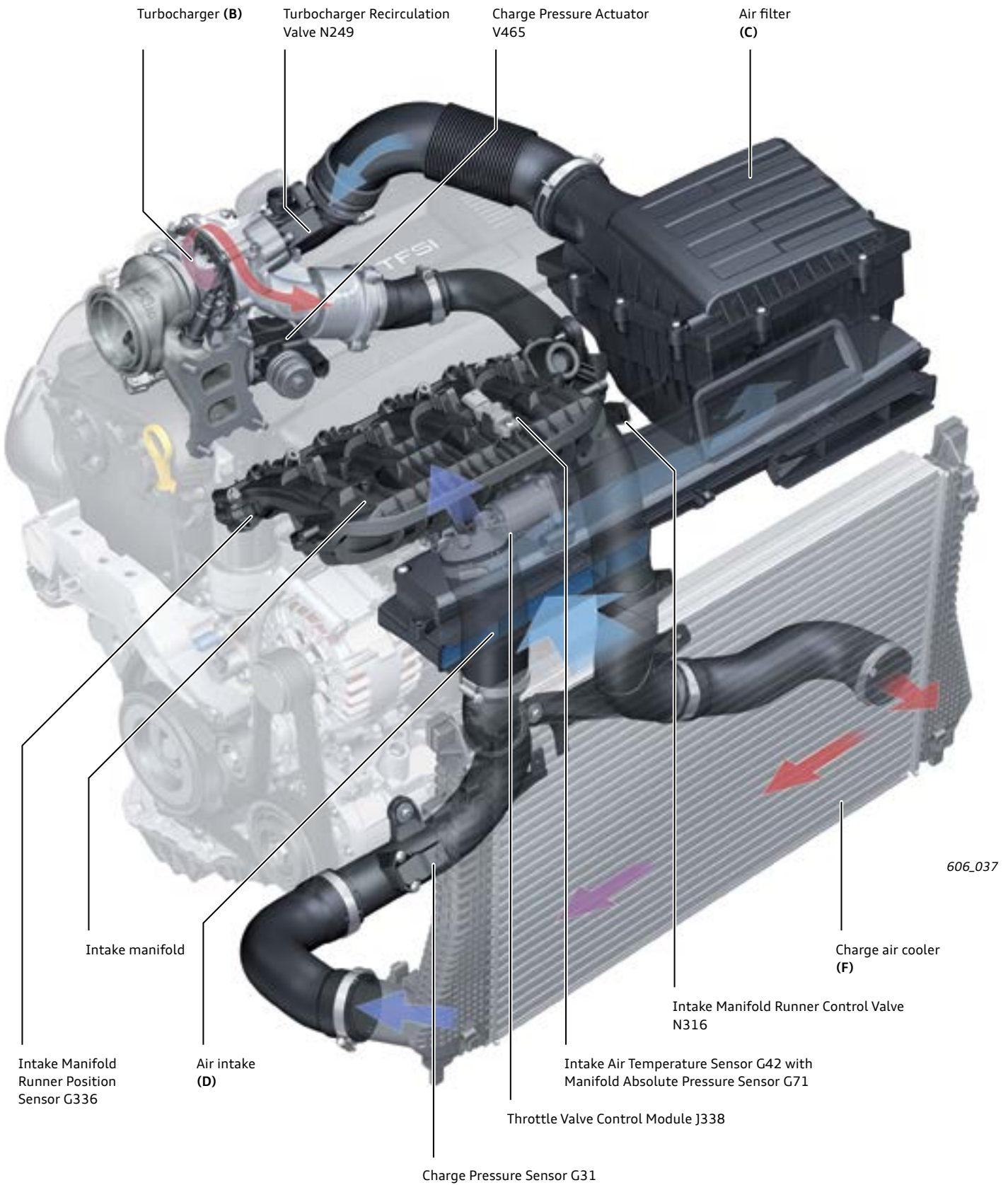

Air routing system for longitudinal mounted engines

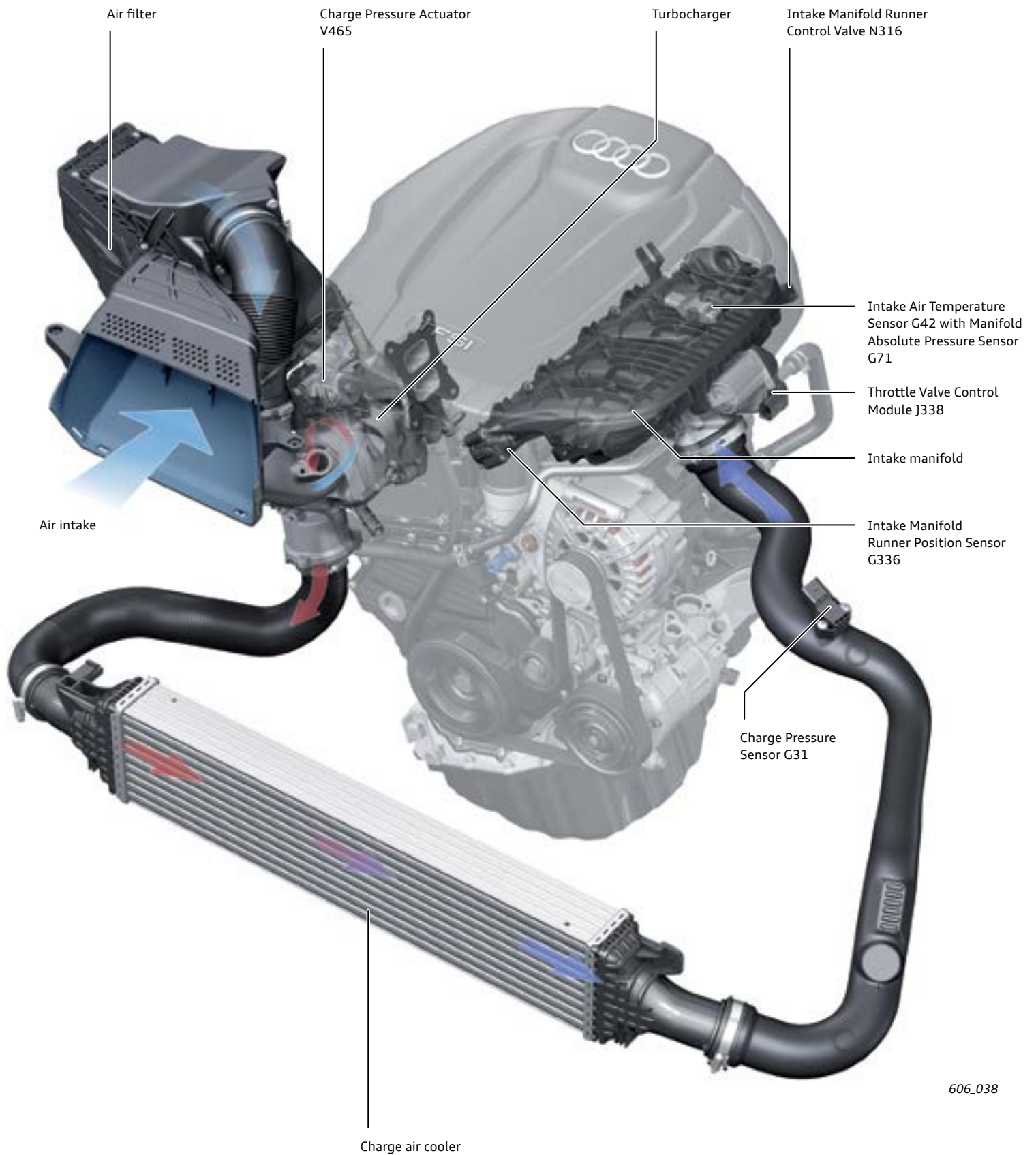

606_038

Intake manifold

To accommodate both FSI and MPI fuel injectors, a newly designed intake manifold was required. The manifold also has pan-shaped flaps to direct air flow in the intake duct. An angled, single piece stainless steel shaft maximizes the torsional rigidity of the flaps. At initial launch of these engines, the North American version will only have FSI injection.

The shaft is actuated by Intake Manifold Runner Control Valve N316 using a vacuum motor based on signals from the ECM.

The pan-shaped flaps are tensioned in the manifold in such a way to minimize excitation by the airflow.

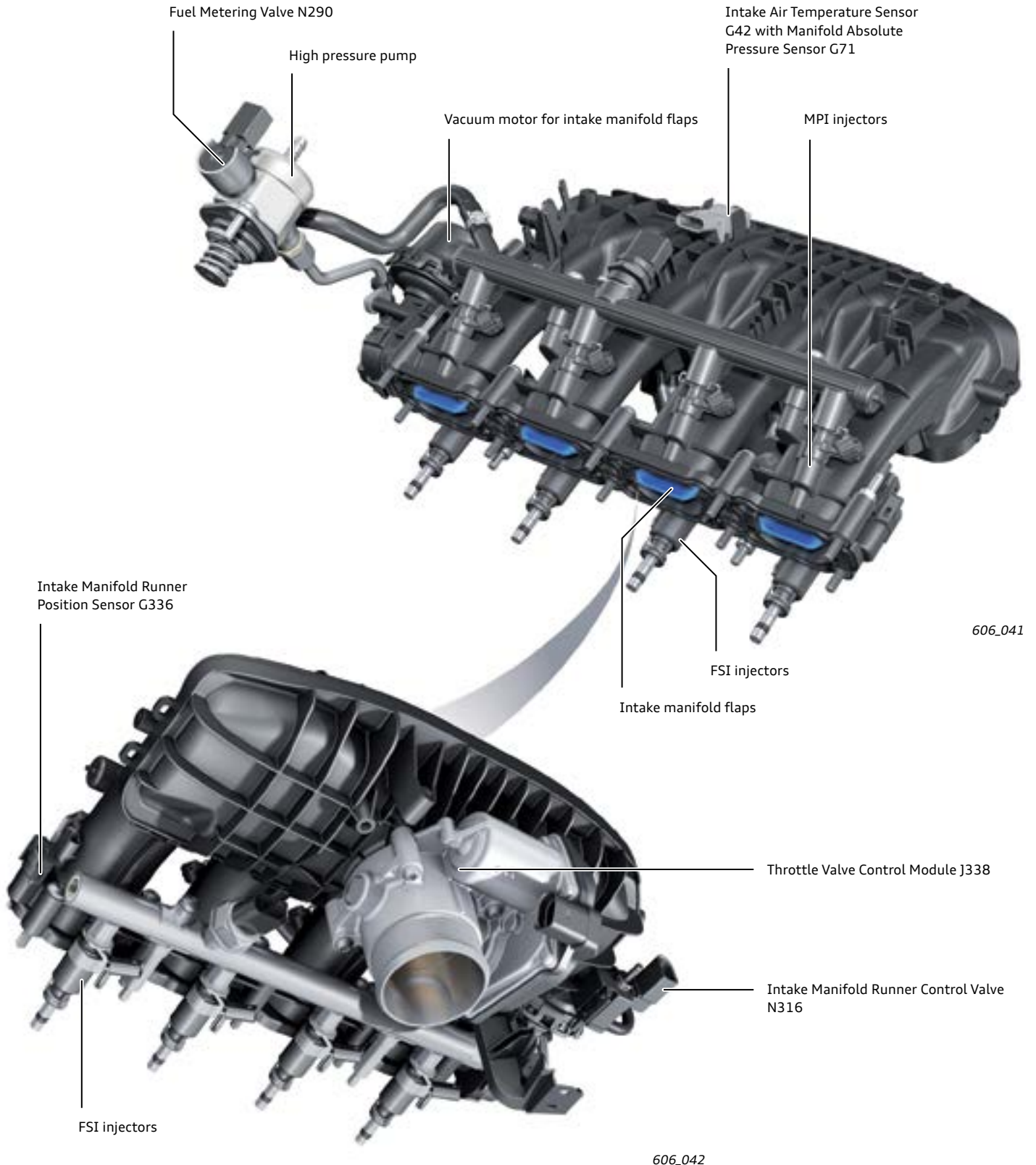

Turbocharger

An all new mono-scroll turbocharger is used on both the 1.8L and 2.0L versions of the third generation EA888 engine. It has the following features:

- ▶ Electrical wastegate actuator (Charge Pressure Actuator V465 with Charge Pressure Actuator Position Sensor G581)
- ▶ Oxygen sensor upstream of turbine (Heated Oxygen Sensor G39)
- ▶ Compact cast steel turbine housing with twin-scroll inlet flanged directly onto the cylinder head
- ▶ Compressor housing with integrated pulsation silencer and Turbocharger Recirculation Valve N249
- ▶ Temperature resistant Inconel turbine wheel rated for temperatures of up to 1796 °F (980 °C)
- ▶ Bearing housing with standard connections for oil and coolant
- ▶ Milled compressor wheel for higher speed resistance and better acoustics
- ▶ Turbine wheel configured as a Mixed Flow Turbine made from Inconel 713 °C

Mono-scroll turbines have only one intake scroll, which directs the exhaust gases to the impeller. In contrast to twin-scroll turbines, they are more simple in design, lighter, and less expensive.

Sensors for detecting air mass and air temperature:

- ▶ Charge Air Pressure Sensor G31 is installed between the charge air cooler and the throttle valve. Its signal is used to monitor and control charge pressure
- ▶ Intake Air Temperature Sensor G42 with Manifold Absolute Pressure Sensor G71

The use of a mono-scroll turbocharger improves full throttle response, particularly at high engine speeds. Twin-scroll channeling of exhaust gases from the cylinder head outlets is continued to a point just short of the turbocharger turbine.

The turbocharger uses a Mixed Flow Turbine design. A Mixed Flow Turbine is a compromise between a radial turbine and an axial turbine. Exhaust gases flow radially through the radial turbine wheel (leading edge is parallel to axis of rotation). Consequently, the turbine is suitable for handling low flow rates, such as those typical of passenger cars. On the other hand, exhaust gases flow axially through the axial turbine wheel (the inlet edge is at an angle of 90° relative to the axis of rotation). This turbine wheel is suitable for handling low flow rates, such as those typical of large displacement engines. Mixed Flow Turbines have a diagonal leading edge. Because this type of turbine has an additional axial impeller, which is ideal for high flow rates, a smaller impeller can also be used. The advantage of better response in the radial turbine is combined with the higher efficiency of the axial impeller in the upper rpm range.

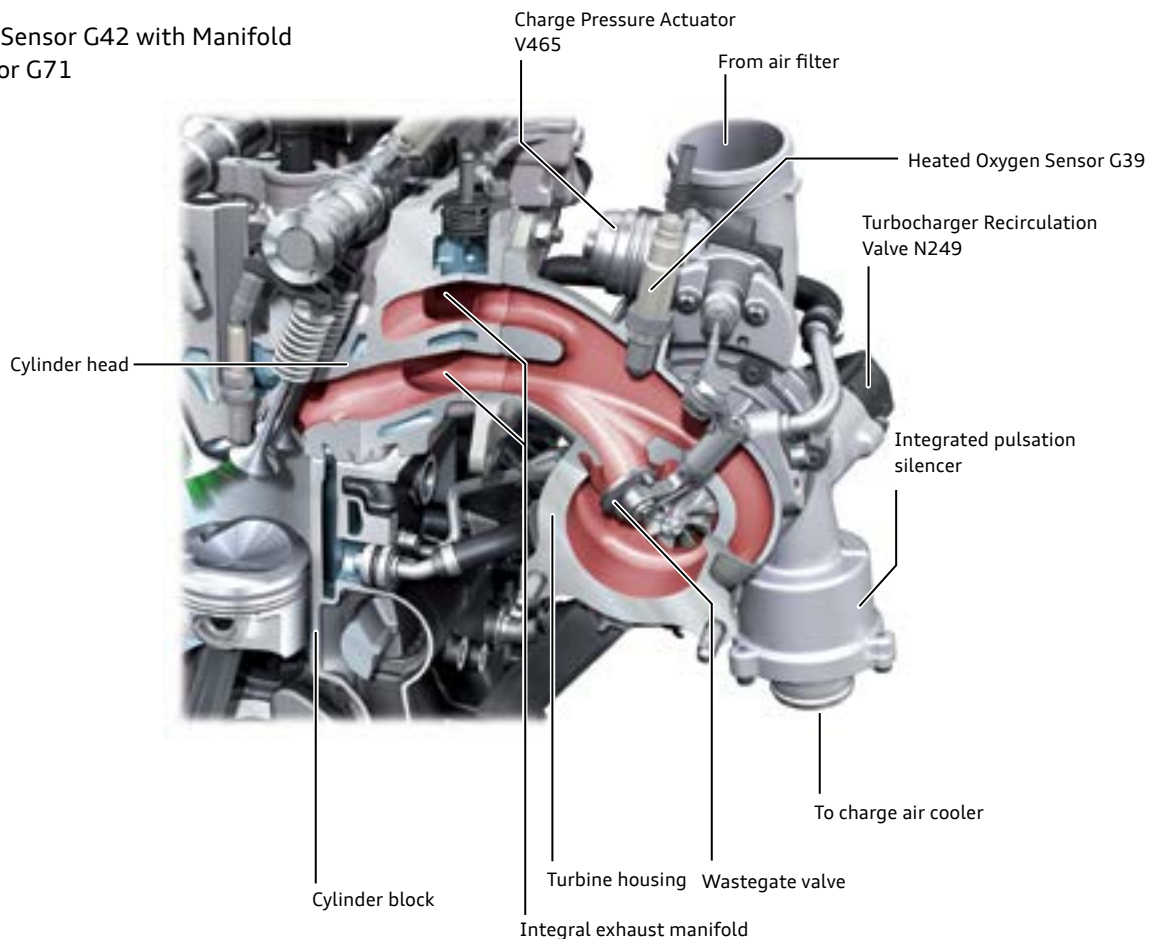

Charge Pressure Actuator V465

An electrical wastegate actuator is used in an Audi turbocharged four-cylinder engine for the first time. This technology offers the following advantages over the previously used vacuum motors:

- ▶ Faster and more precise response
 - ▶ Can be actuated independently of the charge pressure
 - ▶ Due to the higher closing force, the engine achieves its maximum torque at lower engine speeds
- ▶ The active opening of the wastegate at partial throttle allows the basic charge pressure to be reduced. This provides fuel savings
 - ▶ Active opening of the wastegate during the heating phase of the catalytic converter increases the exhaust gas temperature upstream of the catalytic converter by 50 °F (10 °C), resulting in lower cold start emissions.
 - ▶ The adjustment rate of the electrical wastegate actuator allows the immediate build-up of charge pressure during negative load cycles (acceleration), which has a particularly positive overall effect on the acoustic characteristics of the turbocharger (blow-off hiss and groan).

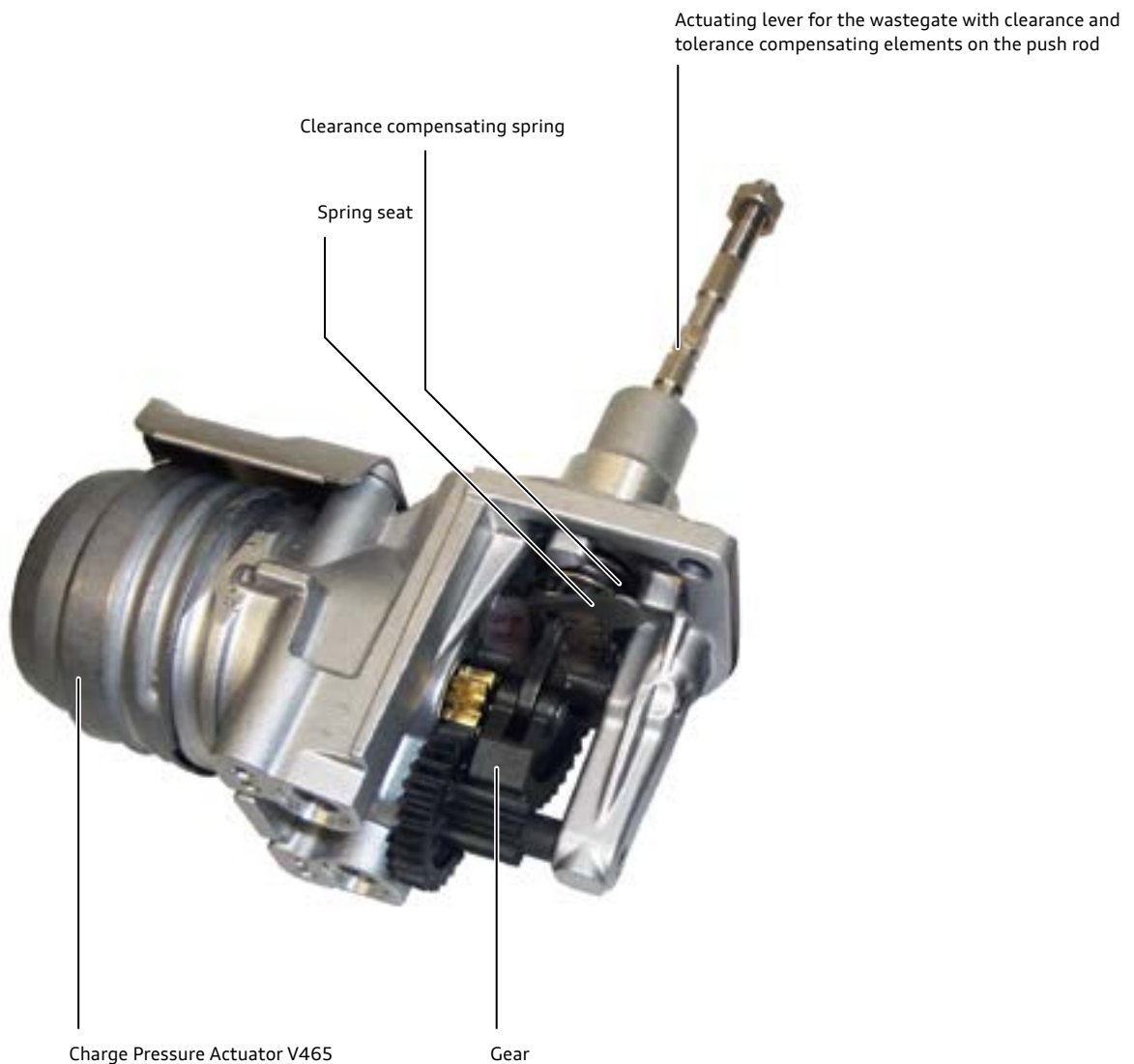

Components of the charge pressure actuator system

The complete actuator consists of the following components:

- ▶ Housing
- ▶ DC motor (Charge Pressure Actuator V465)
- ▶ Gear
- ▶ Integral non-contact position sensor (Charge Pressure Actuator Pressure Sensor G581)
- ▶ Upper and lower internal mechanical stops in gear
- ▶ Clearance and tolerance compensation elements on push rod

Functional diagram

Connections on Charge Pressure Actuator V465:

- ① Sensor + (5 V connection in engine wiring harness)
- ② Actuator -
- ③ Ground
- ④ Not assigned
- ⑤ Sensor signal
- ⑥ Actuator +

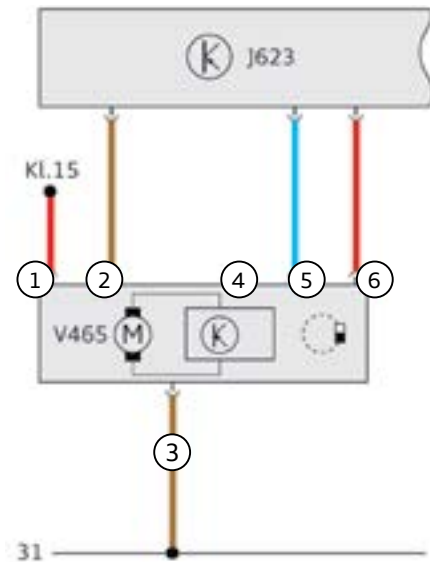

606_020

Operating principle

The DC motor actuates the wastegate valve with the aid of the gear assembly and the push rod. Movement is limited at the lower mechanical stop by the external stop of the seated wastegate valve, and at the upper mechanical stop by the internal gear limiter on the housing.

The activation frequency of the DC motor is controlled by the ECM and lies within a 1000 Hz band.

The push rod is adjustable for length. This allows the wastegate valve to be adjusted after replacing the actuator.

Charge Pressure Actuator Position Sensor G581

G581 is installed in the charge pressure actuator gear housing cover. A magnetic holder with two permanent magnets is also integrated into the housing cover and rests on the spring seat of the gear. It therefore performs the same movement as the push rod. When the push rod moves, the magnets travel past a Hall sensor also located in the housing cover. This allows actual adjustment travel to be measured. The signal from the Hall sensor is an analog, linear voltage signal.



606_079

Turbine housing and turbine wheel

To meet the requirements arising from the increased exhaust gas temperature of approximately 1796 °F (980 °C) and the location of the oxygen sensor upstream of the turbine housing, the turbine housing is made from a new cast steel material.

To optimize ignition sequence separation, the exhaust routing system has a twin-scroll configuration up to a point just before the turbine.

Since the turbine housing has a very compact design, a standard system of studs and nuts is used to connect the housing to the cylinder head. The turbine wheel is configured as a mixed-flow turbine (half-radial turbine).

Heated Oxygen Sensor G39

Heated Oxygen Sensor G39 is a broadband type LSU 4.2 sensor. It is mounted where the exhaust gases from each individual cylinder flow upstream of the turbine housing.

Compressor housing and compressor wheel

The compressor housing has a strength-enhanced design in order to withstand the high actuating forces produced by Charge Pressure Actuator V465. In addition to the compressor wheel, it integrates the pulsation silencer, Turbocharger Recirculation Valve N249, the inlet for the gases from the crankcase breather and the fuel tank vent.

The compressor wheel is milled from a single piece of material. This allows a higher tolerance to high speeds and also reduces compressor noise.

This is the most favorable position because even in this location, temperatures are not too high.

This positioning allows for good individual cylinder recognition and permits oxygen sensor control to be enabled sooner (six seconds) after starting the engine.

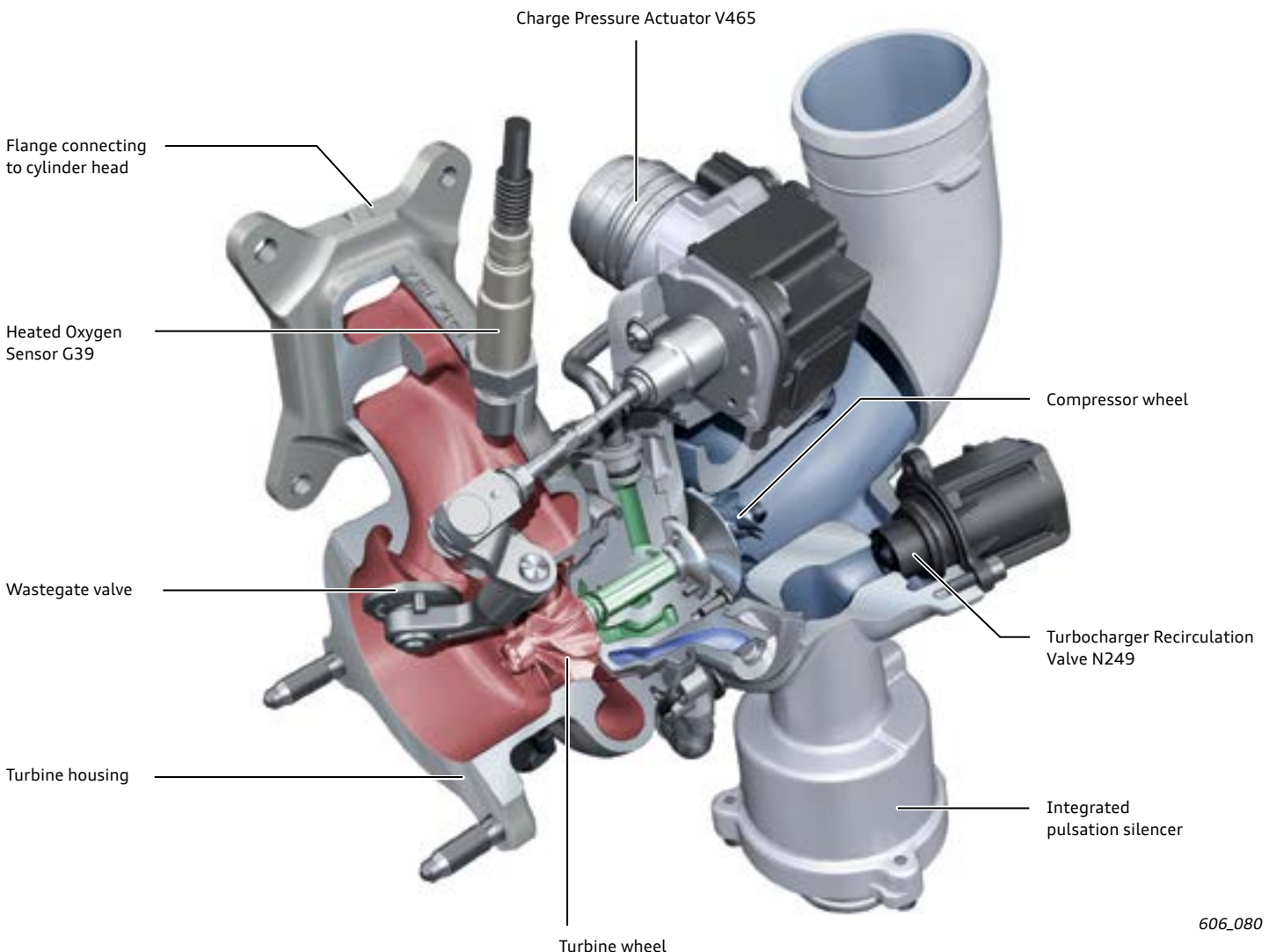

Fuel system

System overview

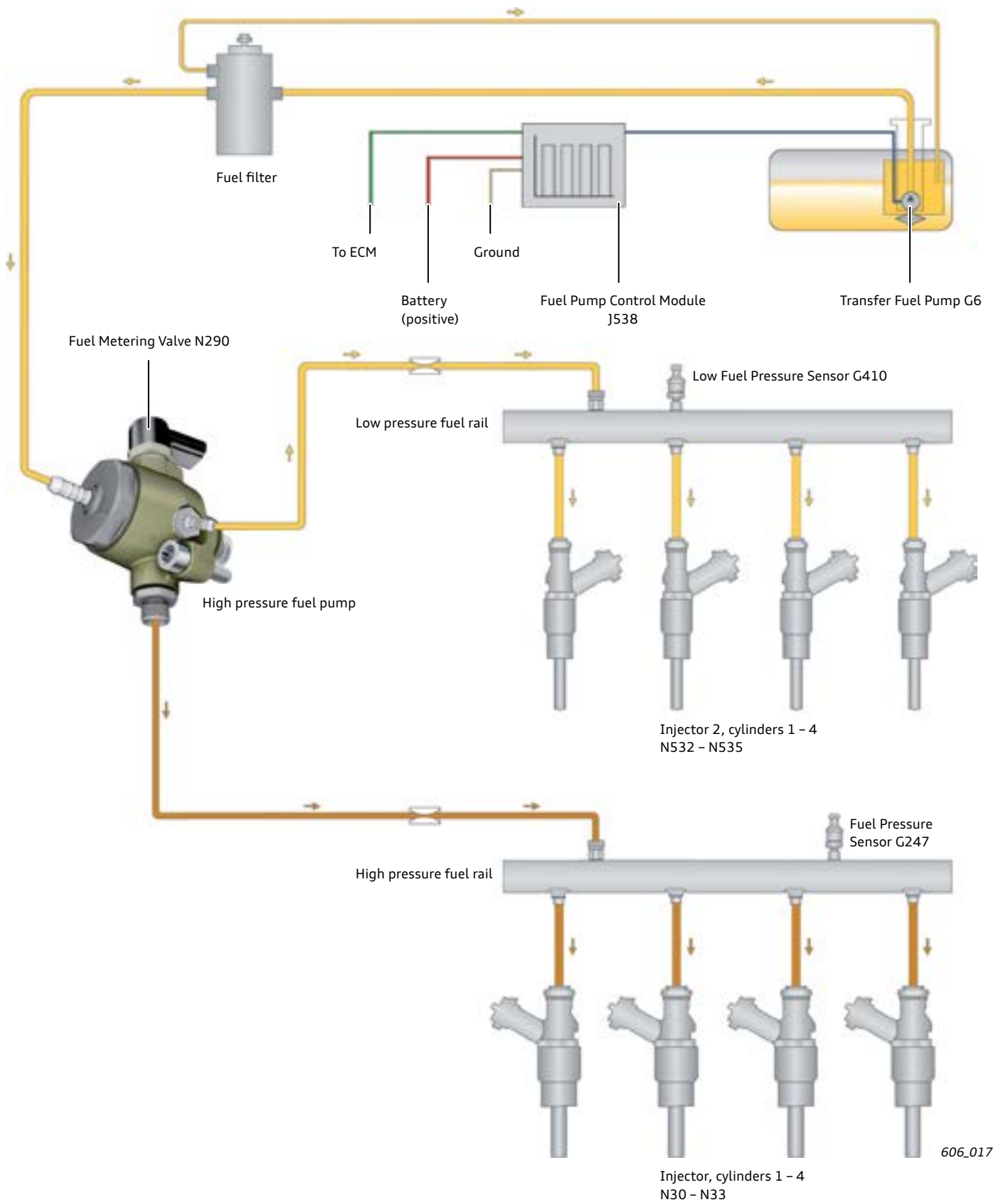

606_017



Note

Only the FSI (high pressure) system will be used on the 2015 A3 engines. The use of MPI and FSI may introduced on later Audi models.

Mixture formation / dual injection system

The dual injection system was developed to reduce the particulate emissions normally associated with FSI engines. This new fuel system is composed of a MPI (multi-port injection) system and an FSI system.

The presentation of this information is for reference and your interest only. The dual injection system may be used in North American Audi models in the future but will not be used at the introduction of the EA888 engine. The intake manifold is the same but the ports for the MPI injectors have not been drilled out.

■ High pressure system
■ Low pressure system

The following goals were accomplished:

- ▶ Increase in system pressure from 2175 psi to 2900 psi (150 bar to 200 bar)
- ▶ Reduced operational noise
- ▶ Compliance with stringent emission limits for particulate mass and volume (significant reduction in soot emissions by a factor of 10)
- ▶ Reduction of exhaust emissions, particularly CO₂, compliance with current and future exhaust emission standards
- ▶ Adaptation of an additional port injection system
- ▶ Improved fuel efficiency at partial throttle through use of MPI injection system

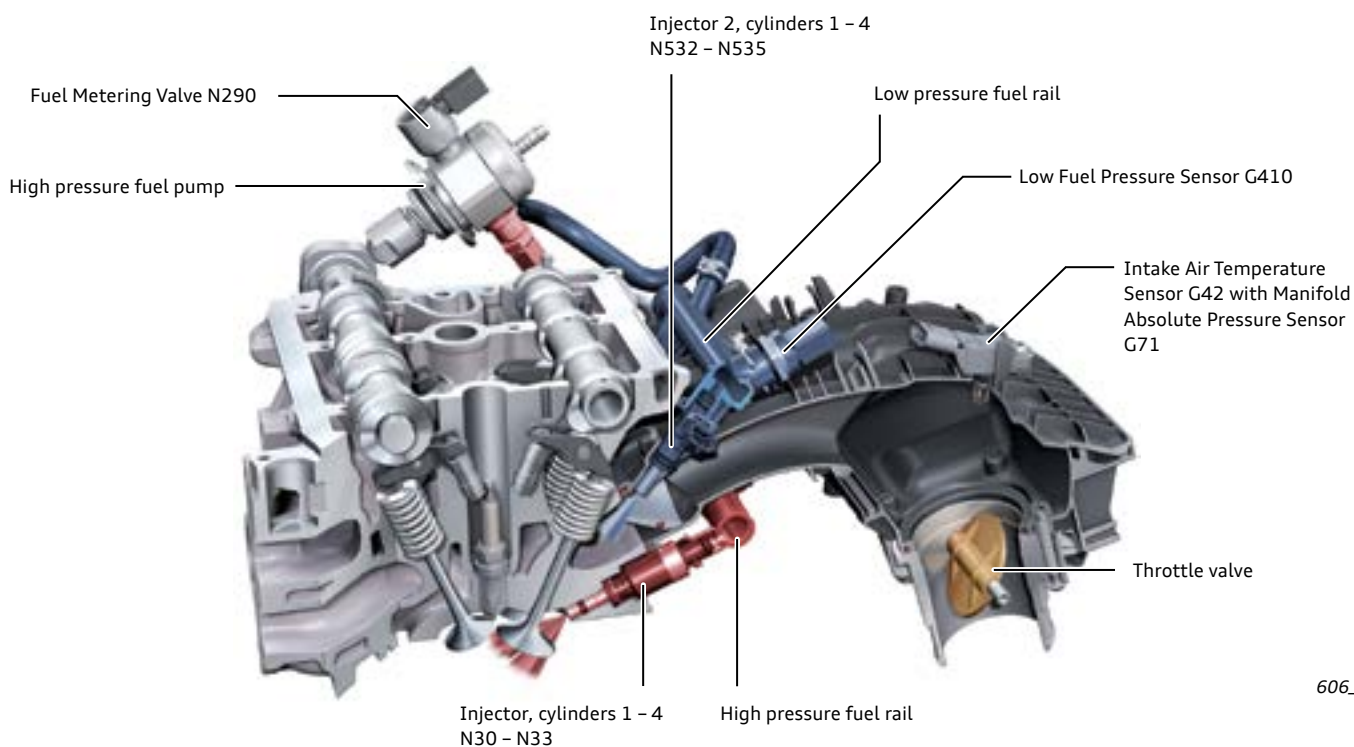

606_012

MPI injection system

The MPI system is supplied via a flushing connection on the high pressure pump. During MPI operation, the high pressure pump is automatically flushed with fuel and thus cooled.

To minimize pulsation, which is transmitted to the rail by the high pressure pump, a restrictor is integrated into the flushing connection on the high pressure pump.

The MPI system has its own pressure sensor - Low Pressure Fuel Sensor G410. Pressure is supplied on demand by the fuel Transfer Pump G6. The Transfer Pump is activated by the Fuel Pump Control Module J538 via the ECM. The MPI rail is made of plastic. The MPI valves (N532 - N535) are integrated into the plastic intake manifold and optimally aligned for fuel injection.

High pressure injection system

All parts in the high pressure tract have been adapted for system pressures of up to 2900 psi (200 bar). The injectors have been sound insulated from the cylinder head using steel spring discs. Likewise, the high pressure rail has been separated from the intake manifold and bolted onto the cylinder head. The position of the high pressure injectors has been slightly retracted. This improves homogenization of the air-fuel mixture and reduces the thermal stress on the valves.

The fuel injection control concept has been modified to ensure harmonized control for all future engines. This rule of thumb applies to the new concept: if the plug from Fuel Pressure Control Valve N276 is disconnected, pressure is no longer built up in the high pressure system.

Operating modes

The ECM determines whether the engine runs in MPI or FSI mode based on specific maps.

To minimize soot emissions, oil thinning and knock tendency, fuel injections are thermodynamically optimized in terms of number and type (MPI or FSI). Naturally, this affects mixture formation. Injection timing and duration must be adapted accordingly.

Direct injection (FSI) is used whenever the engine is started. When the engine coolant temperature is below approximately 113 °F (45 °C) and dependent on engine oil temperature, the engine always runs in direct injection mode.

The objective is to achieve a lambda value of 1 across the widest possible operating range. This is made possible by using the integral exhaust manifold.

As a protective feature, a flushing function is used to prevent coking of the fuel in the high pressure injectors during lengthy periods of MPI operation. At the same time, FSI mode is briefly activated.

Injection type map



606_061

- MPI single injection
- FSI single injection
(homogeneous mode, direct injection during intake stroke)
- FSI dual injection
(homogeneous stratified mode, one single direct injection during intake stroke and one during compression stroke)

* The term indicated torque refers to the torque that a loss-free internal combustion engine would be able to deliver.

Engine start

A triple direct injection is performed during the compression stroke.

Warm-up / catalytic converter heating

Dual direct injection is implemented during the intake and compression strokes. At the same time, the ignition timing is adjusted slightly retarded. The intake manifold flaps are closed.

Engine warm (> 113 °F [45 °C]) at partial throttle

The engine now switches to MPI mode. The intake manifold flaps are also closed at partial throttle, but not 1 : 1 in MPI mode (depending on the parameters in the engine map).

Fuel efficiency advantage

When the engine is warm, optimal mixture homogenization is ensured by advance air-fuel mixing. There is therefore more time available for air-fuel mixture formation, resulting in fast, efficiency-optimized combustion. In addition, no power input is needed to drive the high pressure pump.

Higher load

Dual injection is used here. One direct injection is performed during the intake stroke and one during the compression stroke.

Emergency running function

If either of these systems fails, the other system takes over the emergency running function. This ensures that the vehicle continues to be driveable.



Engine Control Module
J623

606_089

eMedia



Animation showing MPI and FSI operation.

Notes

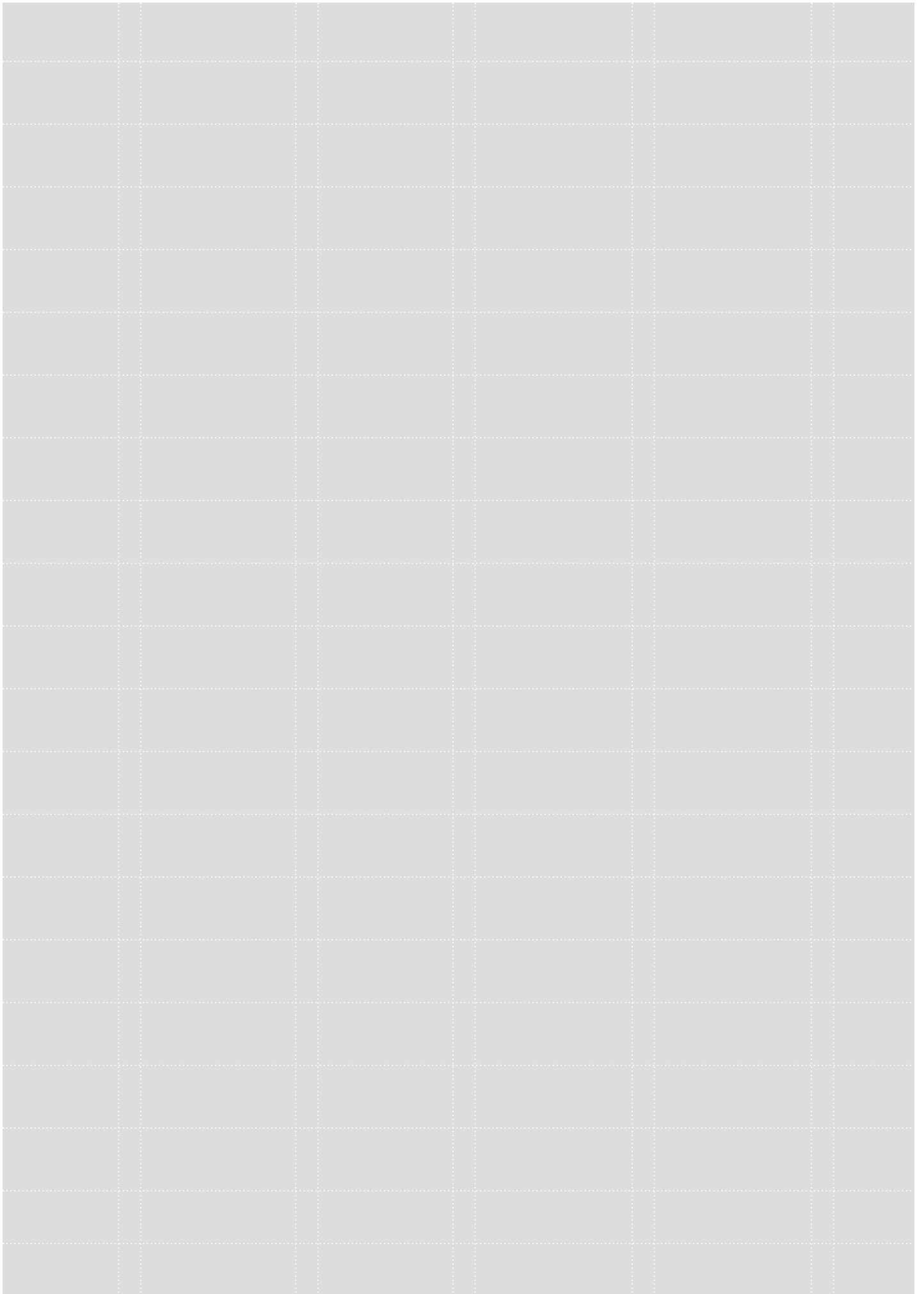

Engine management system

System overview example – 1.8l TFSI engine

Sensors

Throttle Valve Control Module J338
EPC Throttle Drive Angle Sensors 1 & 2 G187, G188

Brake Light Switch F

Clutch Position Sensor G476
Clutch Pedal Switch F36
Clutch Pedal Starter Interlock Switch F194

Accelerator Pedal Position Sensor G79
Accelerator Pedal Position Sensor 2 G185

Knock Sensor 1 G61

Low Fuel Pressure Sensor G410

Hall Sensor G40
Hall Sensor 3 G300

Engine Coolant Temperature Sensor G62

Engine Coolant Temperature Sensor on Radiator Outlet G83

Engine Speed Sensor G28

Oil Level Thermal Sensor G266

Intake Manifold Runner Position Switch G336

Intake Air Temperature Sensor G42
Manifold Absolute Pressure Sensor G71

Fuel Pressure Sensor G247

Charge Air Pressure Sensor G31

Gear Recognition Sensor G604

Brake Booster Pressure Sensor G294

Heated Oxygen Sensor G39
Oxygen Sensor after Three Way Catalytic Converter G130

Oil Pressure Switch F22
Reduced Oil Pressure Switch F378
Oil Pressure Switch, Level 3 F447

Charge Pressure Actuator Position Sensor G581

Fuel Level Sensor G
Fuel Level Sensor 2, G169

Auxiliary signals:
– Cruise control system
– Speed signal
– Start request to engine control module (keyless start 1 + 2)
– Terminal 50
– Crash signal from airbag control Module

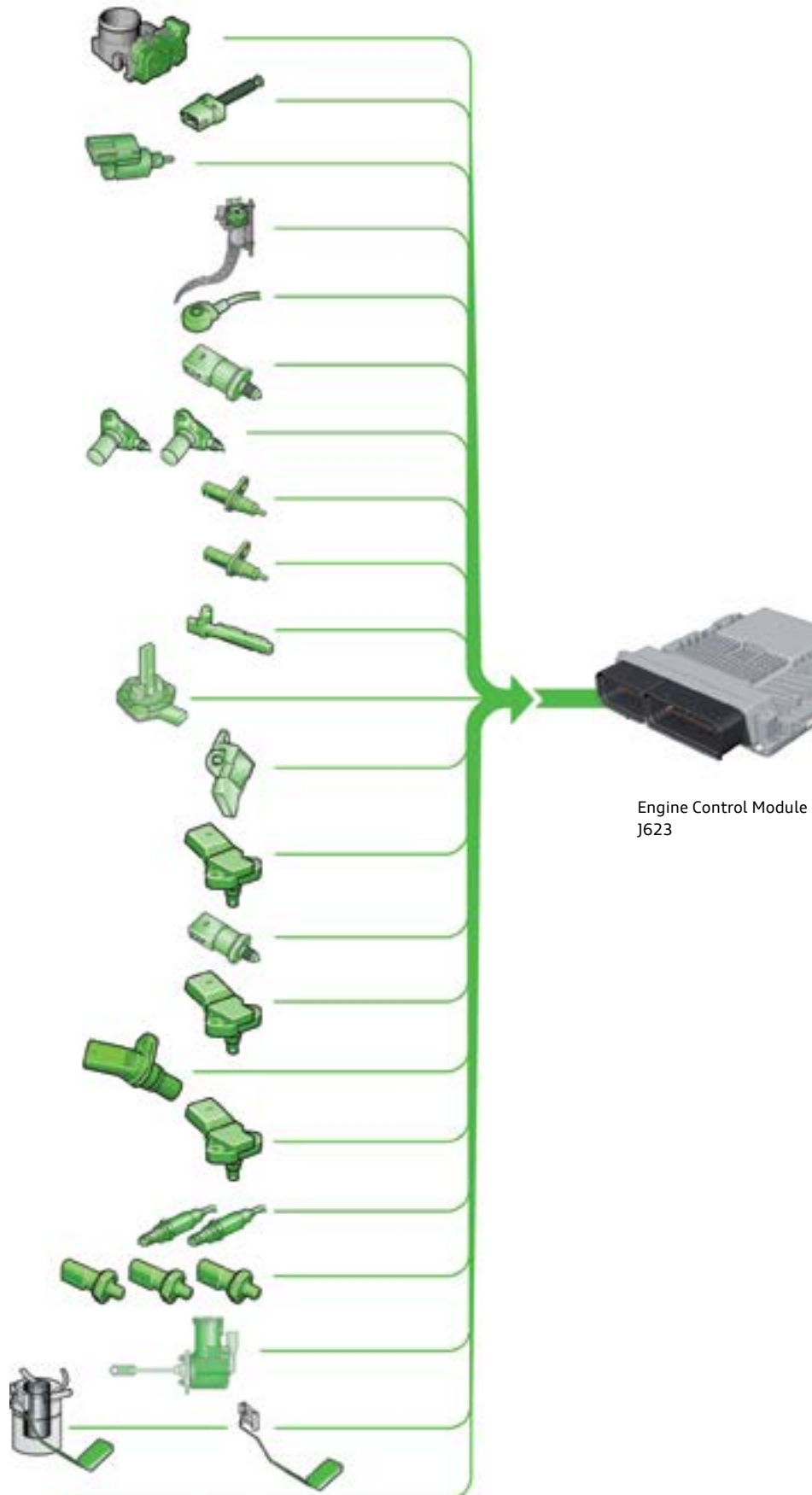

Actuators

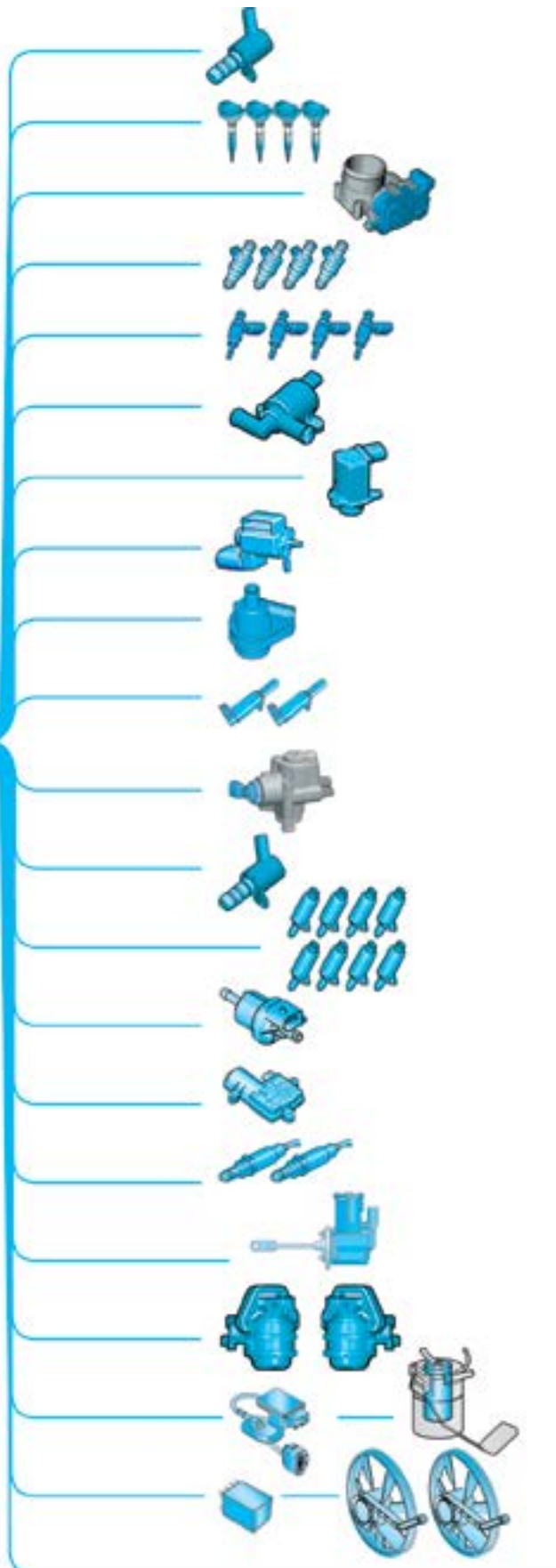

Piston Cooling Nozzle Control Valve N522

Ignition Coils 1 - 4 with Output Stage
N70, N127, N291, N292

EPC Throttle Drive G186

Injectors 2, cylinders 1 - 4 N532 - N535

Injector, cylinders 1 - 4 N30 - N33

Transmission Coolant Valve N488

Turbocharger Recirculation Valve N249

Intake Manifold Runner Control Valve N316

Coolant Recirculation Pump V50

Camshaft Adjustment Valve 1 N205
Exhaust Camshaft Adjustment Valve 1 N318
(N318 only on 2.0L engines)

Fuel Metering Valve N290

Oil Pressure Regulation Valve N428

Cam Adjustment Actuators 1 - 8, F366, F373
(only on 2.0L engines)

Carbon Canister Purge Regulator Valve N80

Engine Temperature Control Actuator N493

Oxygen Sensor Heater Z19
Heater for Oxygen Sensor 1 after Catalytic Converter Z29

Charge Pressure Actuator V465

Left Electro-hydraulic Engine Mount Solenoid Valve N144
Right Electro-hydraulic Engine Mount Solenoid Valve N145

Fuel Pump Control Module J538
Transfer Fuel Pump G6

Coolant Fan Control Module J293
Coolant Fan V7
Coolant Fan 2 V177

Auxiliary signals:
- Dual clutch Mechatronic Module / engine speed
- ABS/ESP Control Module
- A/C compressor
- Starter control Module

Differences between 1.8L longitudinally and transversely mounted engines

The following components have been adapted:

- ▶ Oil pan top section
- ▶ Honeycomb insert
- ▶ Oil pump intake line
- ▶ Oil pan
- ▶ Exhaust turbocharger

The top and bottom sections of the oil pan, the honeycomb insert and the oil pump intake line have been modified so that the initial oil fill is the same as before 5.7 qt (5.4L) and that the oil system meets all the essential functional criteria, e.g. oil pressure, oil sludging, longitudinal and lateral dynamics, uphill and downhill driving.

eMedia



Animation showing the differences between the longitudinally and transversely mounted engines using the 1.8L TFSI engine as an example.

1.8L TFSI engine, transversely mounted

Turbocharger



Honeycomb insert



Oil pump intake line



Oil pan top section



Oil pan



606_071

Differences between components in the engines with 1.8 l and 2.0 l displacement

Different parts:

- ▶ Cylinder block (main bearing diameter 2.04 in [52 mm])
- ▶ Crankshaft (stroke 3.62 in [92.8 mm])
- ▶ Connecting rod with adapted inside micrometer
- ▶ Main bearings 2.04 in ([52 mm], two-component bearings are used throughout the entire kit)
- ▶ Balancer shafts
- ▶ Exhaust camshaft (valve lift 10 mm, adapted valve timing)
- ▶ Exhaust valves (hollow, bimetallic)
- ▶ High pressure injectors (higher flow rate)
- ▶ Intake manifold with integral drumble flap
- ▶ Exhaust turbocharger

eMedia



Animation showing the differences between 1.8 l and 2.0 l displacements using the longitudinally mounted engine as an example.

2.0l TFSI engine, transversely mounted

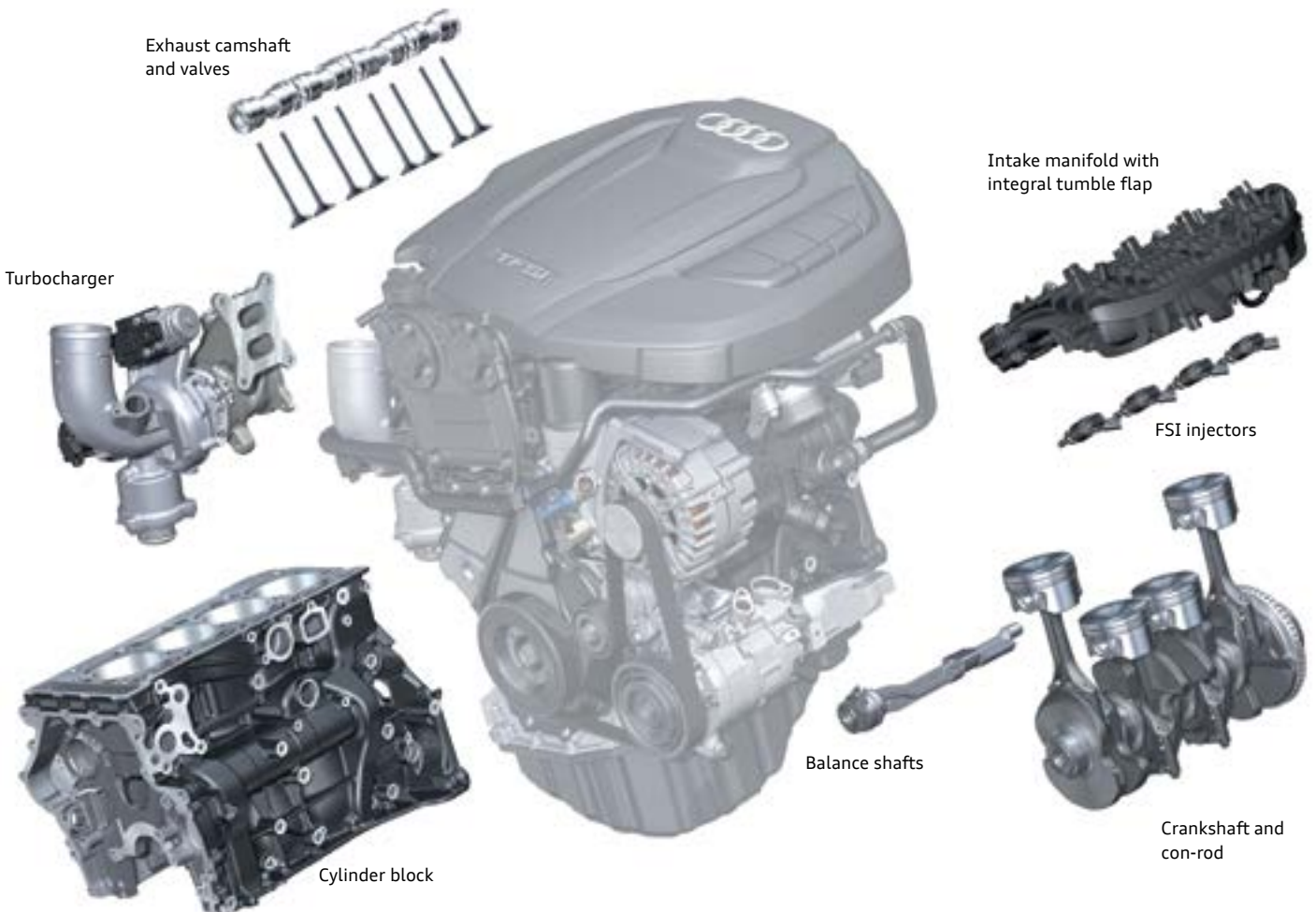

606_072

Component differences for the 2015 Audi S3

The following parts have been adapted:

- ▶ Cylinder head (made from a different alloy compared to other engines in this module because of higher thermal stress)
- ▶ Exhaust valves (hollow, higher Ni content, nitrided)
- ▶ Exhaust valve seat rings (improved temperature stability and wear resistance)
- ▶ Exhaust camshaft (adapted valve timings)
- ▶ Compression ratio 9.3 : 1
- ▶ Piston cooling jets (higher flow rate)
- ▶ High pressure injectors (even higher flow rate)
- ▶ Exhaust turbocharger
- ▶ Charge pressures of up to 17.4 psi (1.2 bar)
- ▶ High performance main radiator with 1 – 2 auxiliary radiators (depending on country specifications)
- ▶ Additional acoustic modifications have been made in order to achieve a sporty sound - use of a sound actuator (for the occupant cell) and active exhaust flaps in the exhaust system

eMedia



Animation showing the 2015 Audi S3.

2.0l TFSI engine in Audi S3 '13

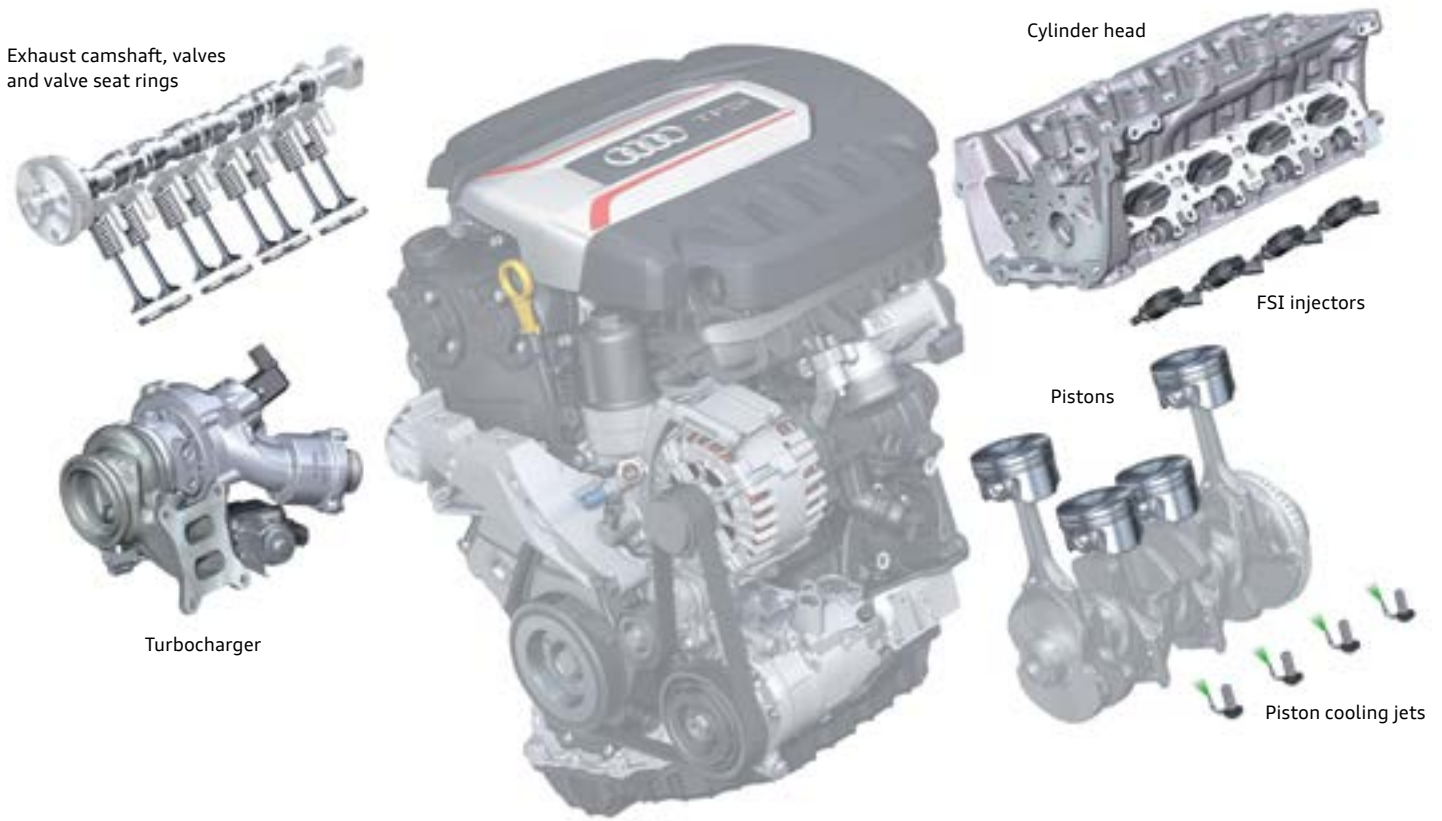

606_073

eMedia



Animation showing the different components of the 2015 S3 engine.

Differences between the exhaust turbochargers

Even larger compressor and turbine wheels and specially adapted housing components are used for the 2015 Audi S3. Different materials are used for the turbine housing and the turbine wheel so they are able to handle the high exhaust gas mass flow rates.

A special feature of the Audi S3 turbocharger is the use of "abradeable seal" technology (ICSI GmbH) in the compressor.

A self-adaptive plastic insert provides a much smaller gap between the compressor wheel and housing. This increases the efficiency of the compressor unit by up to 2%.

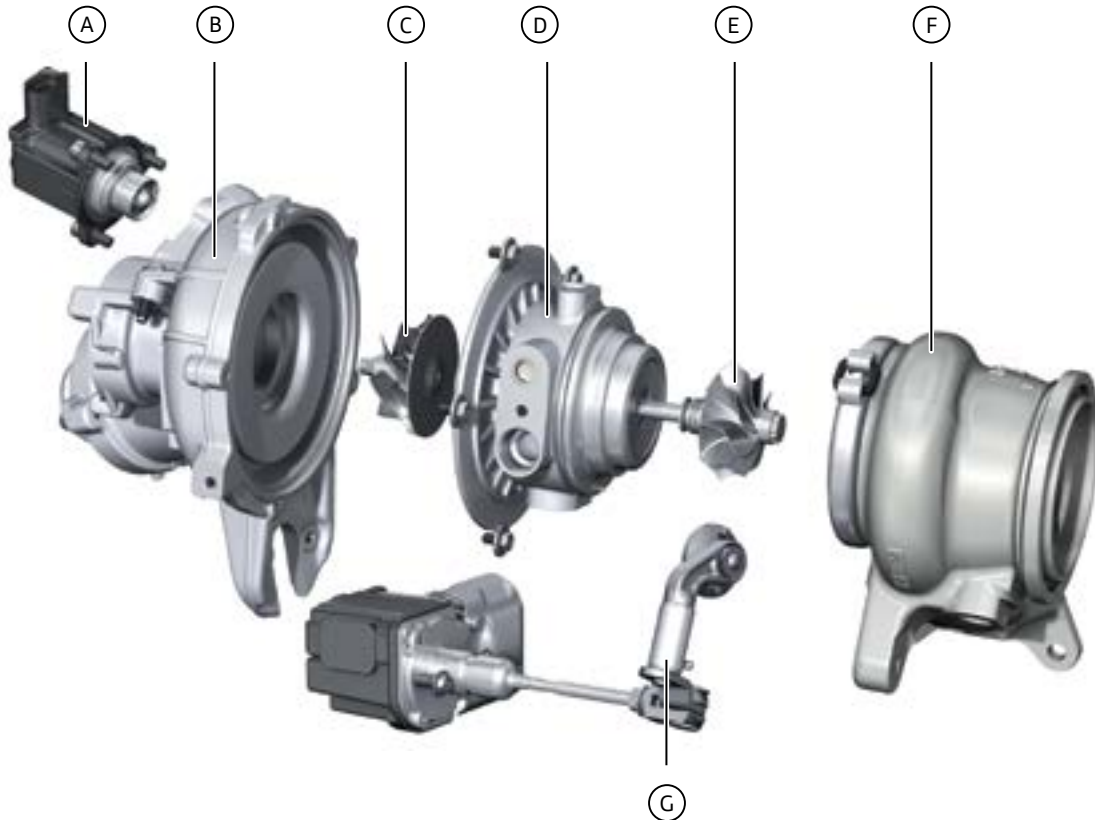

606_074

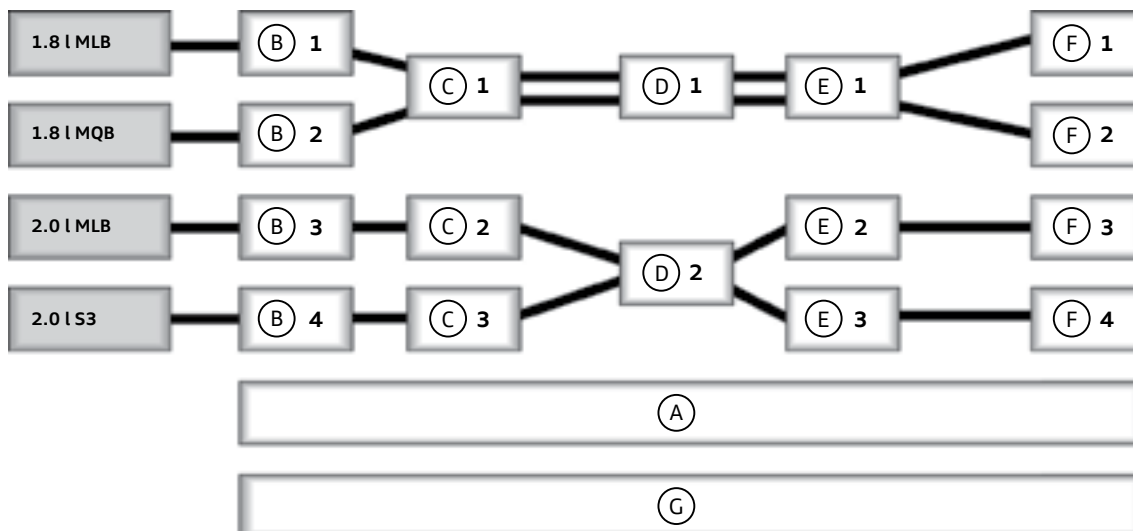

606_078

Key:

- (A) Electrical diverter valve
- (B) Compressor housing
- (C) Compressor wheel
- (D) Bearing
- (E) Turbine wheel
- (F) Turbine housing
- (G) Wastegate system

MQB = transversely mounted engine
MLB = longitudinally mounted engine

Differences between combustion methods

	1.8 l	2.0 l	2.0 l S3
High pressure injector flow rate	15 cm ³ /s	17.5 cm ³ /s	20 cm ³ /s
Intake ports	Tumble duct	Tumble duct	Tumble duct
Flap system	Tumble	Drumble	Drumble
Compression ratio	9.6 : 1	9.6 : 1	9.3 : 1
Intake camshaft adjuster	yes	yes	yes
Exhaust camshaft adjuster	no	yes	yes
Exhaust - Audi valvelift system (AVS)	no	yes	yes
Integral exhaust manifold	yes	yes	yes

Drumble flap

Depending on displacement, differing degrees of charge motion occur when the intake flap is closed. To achieve the same results, it would be necessary to use different intake manifolds for the different displacements. To eliminate this problem, different swirl flaps are used.

Drumble flaps are installed on the 2.0L versions of the third generation EA888 engines.

In this design, the tumble duct is closed asymmetrically to induce a combined swirling and tumbling flow motion in the air/fuel charge.

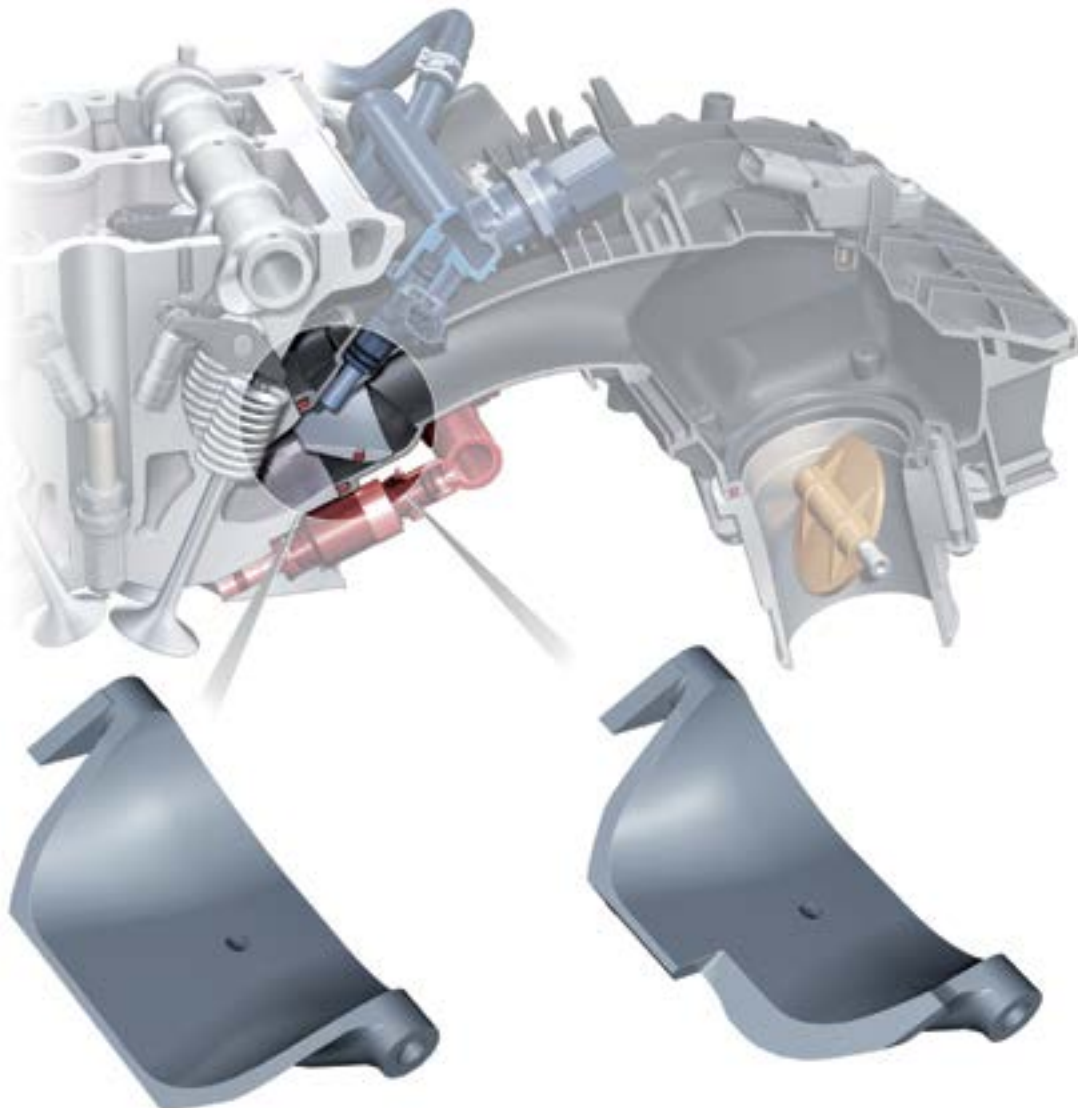

Tumble flap in
1.8l TFSI engines

Drumble flap in
2.0l TFSI engines

606_075

Special tools

T10133/16 A Removal tool



606_048

For removing the high pressure injectors
Special tool T10133/16 A replaces the previous removal tool (T10133/16)

T10133/18 Sleeve



606_049

For removing the high pressure injectors

T40243 Lever



606_050

For inserting the crankshaft tensioner

T40267 Locking tool



606_051

For locking the clamping element

T40274 Puller hook



606_054

For removing the crankshaft seal

T40270 Socket insert XZN 12



606_052

For removing and installing the engine/ transmission mounts

T40271 Camshaft clamp



606_053

For locking the drive chain sprockets

T40290 Setting gauge



606_081

For locking the wastegate during adjustment work on the charge pressure actuator of the exhaust turbocharger

Self Study Programs

To find out more about the technology of the EA888 engine family, refer to the following Self Study Programs.



**eSelf-Study Program 921103,
The Audi 3.0L V6 Engine.**



**eSelf-Study Program 921703,
The Audi 2.0 Liter Chain-driven
TFSI Engine.**



**eSelf-Study Program 922903,
The 2.0L 4V TFSI Engine with
AVS.**

Knowledge Assessment

An On-Line Knowledge Assessment (exam) is Available for this eSelf-Study Program.

The Knowledge Assessment is required for Certification.

You can find this Knowledge Assessment at:

www.accessaudi.com

From the [accessaudi.com](http://www.accessaudi.com) Homepage:

- ▶ Click on the “ACADEMY” tab
- ▶ Click on the “Academy site” link
- ▶ Click on the Course Catalog Search and select “920243 - The Audi 1.8L and 2.0L Third Generation EA888 Engines”

Please submit any questions or inquiries via the Academy CRC Online Support Form which is located under the “Support” tab or the “Contact Us” tab of the Academy CRC.

Thank you for reading this eSelf-Study Program and taking the assessment.

All rights reserved.
Technical specifications are
subject to change without notice.

Audi of America, LLC
2200 Ferdinand Porsche Drive
Herndon, VA 20171