



Technical Bulletin

Model(s)	Year(s)	Eng. Code(s)	Trans. Code(s)	VIN Range From	VIN Range To
Jetta, Jetta Wagon	2009	2.0L TDI (CBEA)	All	All	All
Jetta	2010	2.0L TDI (CJAA)	All	All	All
Golf, Jetta SportWagen, Golf Wagon	2010-2014	2.0L TDI (CJAA)	All	All	All
Jetta	2011-2014	2.0L TDI (CJAA)	All	All	All
Beetle, Beetle Convertible	2013-2014	2.0L TDI (CJAA)	All	All	All

Condition

21 15 02 January 20, 2014 2025464 Supersedes T. B. V211404 dated May 1, 2014 for labor operation update.

Frozen Charge Air Cooler – Engine Will Not Start

Engine will not start after standing in cold weather below 0°C (32°F), MIL may be illuminated with various induction and/or boost system faults stored in ECM.

Technical Background

Moisture from the intake air condenses and collects in the charge air cooler. At cold temperatures this moisture can freeze causing blockage of the intake air system.

Production Solution

None.

Technical Bulletin

Service

Install revised charge air cooler kit P/N 1K0 198 803B to avoid the formation of this moisture in the boost system.

Procedure

- Lock carrier in service position. See Repair Manual Group 50 in Elsa.
- Separate A/C condenser from charge air cooler.
- Remove radiator and radiator fan assembly.
- Remove the original charge air cooler (item 3 in figure 1) from the vehicle.

Tip:

Charge air hoses can be difficult to remove at the charge air cooler, try separating the hoses from the hot and cold charge air pipes before loosening charge air cooler.

- Remove the lower charge pressure hoses (items 4 and 16 in figure 1) and clean of any moisture, ice crystal formation or sludge. See Repair Manual Group 21, Turbocharger/G-Charger, Description and Operation, Component Overview, in Elsa.

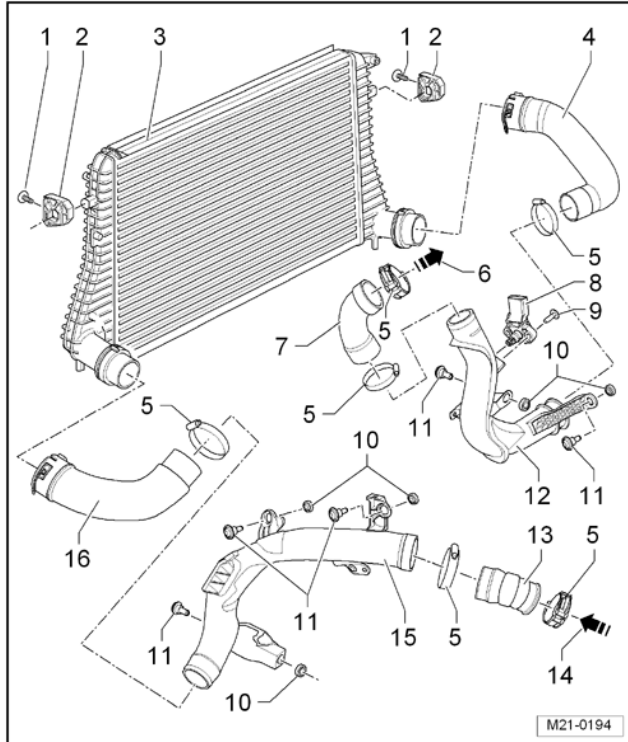

Figure 1

Technical Bulletin

- Remove cold side charge air pipe (item 12 in figure 1) and pressure hose to throttle valve (item 7 in figure 1).
- Separate the A/C condenser from the charge air cooler.
- Remove the radiator and radiator fan assembly.
- Separate the charge air pressure sensor –G31-- from cold side charge air pipe.
- Install charge air pressure sensor -G31- from kit to cold side charge air pipe.
- Loosely fit the pressure hose with new temperature switch to the cold side charge air pipe.

 **Tip:**

By loosely installing pressure hose with switch to cold side charge air pipe allows for “wobble room” when reinstalling.

- Install the cold side charge air pipe (item 12 in figure 1) and connect the charge air pressure sensor -G31- electrical connector.

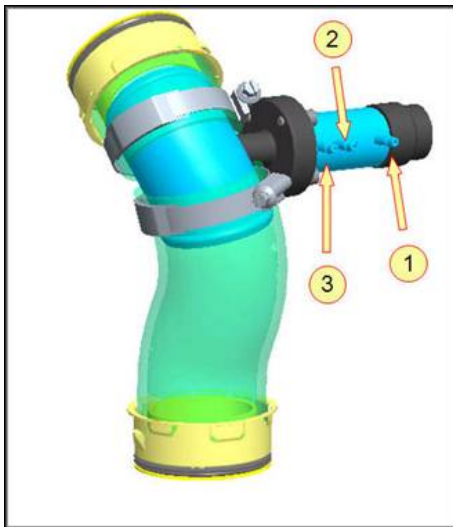

- Note the vacuum hose routing on the temperature switch (figure 2).
1. Ventilation hose to air cleaner
 2. Hose to vacuum source
 3. Hose to charge air cooler regulator flap

Figure 2

Technical Bulletin

- Route vacuum overlay harness as seen in figures 3 and 4.

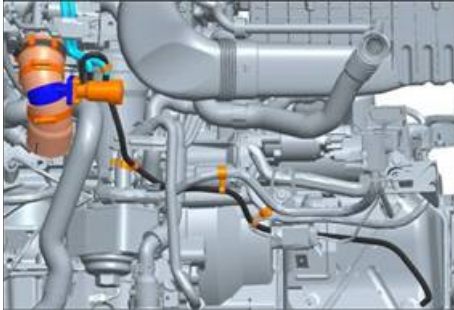

Figure 3

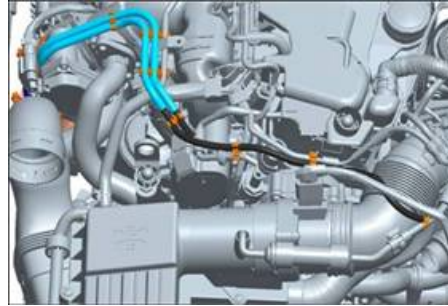

Figure 4



Figure 5

- Cut ventilation hose to air cleaner where indicated in figure 5.

Technical Bulletin



Figure 6

- Install splice as indicated in figure 6.

 **Tip:**

Note the white tracer on the vacuum hose in figure 6.



Figure 7

- Cut vacuum source hose where indicated in figure 7, and install splice.



Technical Bulletin

- Install the revised charge air cooler (item 3 in figure 1) with regulating flap and connect the regulating flap vacuum hose.
- Re-assemble all charge air pipe connections.
- Connect A/C condenser to charge air cooler using fasteners from kit, and install radiator with fan assembly.
- Reassemble front carrier.
- Re-aim headlights.



Technical Bulletin

Warranty

Please verify engine code for accurate warranty table selection.

To determine if this procedure is covered under Warranty, always refer to the Warranty Policies and Procedures Manual ¹⁾					
Model(s)	Year(s)	Eng. Code(s)	Trans. Code(s)	VIN Range From	VIN Range To
Jetta, Jetta Wagon	2009	2.0L TDI (CBEA)	All	All	All
Jetta	2010	2.0L TDI (CJAA)	All	All	All
SAGA Coding					
Claim Type:		Use applicable Claim Type ¹⁾			
Service Number:		Damage Code	HST	Damage Location (Depends on Service No.)	
2143		0055	--	Use applicable when indicated in ElsaWeb (L/R)	
Parts Manufacturer		Jetta, Jetta Wagon		3ME ²⁾	
Labor Operation ³⁾ : Replace Charge Air Cooler			21431983 = 20 TU		
Labor Operation ³⁾ : Remove and Install Radiator			19701983 = 70 TU		
Labor Operation ³⁾ : Lock Carrier Service Position			50380950 = 40 TU		
Labor Operation ³⁾ : Remove and Install Front Bumper Cover			63291900 = 70 TU OR 63291910 = 90 TU (Cup Edition Only)		
Labor Operation ³⁾ : Install Cold Weather Intercooler Kit			21433199 = 30 TU max.		



Technical Bulletin

Causal Part:		1K0 198 803 B
Diagnostic Time ⁴⁾		
GFF Time expenditure	01500000 = 30 TU max.	YES
Road Test	01210004 = 10 TU	YES
Technical Diagnosis	01320000 = 00 TU max.	NO
Claim Comment: Input "As per Technical Bulletin 2025464" in comment section of Warranty Claim.		
<p>¹⁾ Vehicle may be outside any Warranty in which case this Technical Bulletin is informational only</p> <p>²⁾ Code per warranty vendor code policy.</p> <p>³⁾ Labor Time Units (TUs) are subject to change with ELSA updates.</p> <p>⁴⁾ Documentation required per Warranty Policy Procedures Manual.</p>		

Please verify engine code for accurate warranty table selection.

To determine if this procedure is covered under Warranty, always refer to the Warranty Policies and Procedures Manual ¹⁾					
Model(s)	Year(s)	Eng. Code(s)	Trans. Code(s)	VIN Range From	VIN Range To
Golf	2010-2014	2.0L TDI (CJAA)	All	All	All
SAGA Coding					
Claim Type:		Use applicable Claim Type ¹⁾			
Service Number:	Damage Code	HST		Damage Location (Depends on Service No.)	
2143	0055	--		Use applicable when indicated in ElsaWeb (L/R)	
Parts Manufacturer		Golf		WVO²⁾	
Labor Operation ³⁾ : Replace Charge Air Cooler (includes radiator R&l, drain & fill)			21431983 = 130 TU		



Technical Bulletin

Labor Operation ³⁾ : Lock Carrier Service Position	50380950 = 70 TU	
Labor Operation ³⁾ : Remove and Install Front Bumper Cover	63291950 = 40 TU	
Labor Operation ³⁾ : Remove and Install Radiator Grille	66051900 = 20 TU	
Labor Operation ³⁾ : Install Cold Weather Intercooler Kit	21433199 = 30 TU max.	
Causal Part:	1K0 198 803 B	
Diagnostic Time ⁴⁾		
GFF Time expenditure	01500000 = 30 TU max.	YES
Road Test	01210004 = 10 TU	YES
Technical Diagnosis	01320000 = 00 TU max.	NO
Claim Comment: Input "As per Technical Bulletin 2025464" in comment section of Warranty Claim.		
¹⁾ Vehicle may be outside any Warranty in which case this Technical Bulletin is informational only ²⁾ Code per warranty vendor code policy. ³⁾ Labor Time Units (TUs) are subject to change with ELSA updates. ⁴⁾ Documentation required per Warranty Policy Procedures Manual.		

Please verify engine code for accurate warranty table selection.

To determine if this procedure is covered under Warranty, always refer to the Warranty Policies and Procedures Manual ¹⁾					
Model(s)	Year(s)	Eng. Code(s)	Trans. Code(s)	VIN Range From	VIN Range To
Jetta	2011-2014	2.0L TDI (CJAA)	All	All	All
SAGA Coding					
Claim Type:	Use applicable Claim Type ¹⁾				



Technical Bulletin

Service Number:	Damage Code	HST	Damage Location (Depends on Service No.)
2143	0055	--	Use applicable when indicated in ElsaWeb (L/R)
Parts Manufacturer	Jetta	3ME ²⁾	
Labor Operation ³⁾ : Replace Charge Air Cooler (includes radiator R&I, drain & fill)		21431983 = 160 TU	
Labor Operation ³⁾ : Remove and Install Front Bumper Cover		63291950 = 40 TU	
Labor Operation ³⁾ : Remove and Install Radiator Grille		66051900 = 20 TU	
Labor Operation ³⁾ : Install Cold Weather Intercooler Kit		21433199 = 30 TU max.	
Causal Part:		1K0 198 803 B	
Diagnostic Time ⁴⁾			
GFF Time expenditure	01500000 = 30 TU max.	YES	
Road Test	01210004 = 10 TU	YES	
Technical Diagnosis	01320000 = 00 TU max.	NO	
Claim Comment: Input "As per Technical Bulletin 2025464" in comment section of Warranty Claim.			
¹⁾ Vehicle may be outside any Warranty in which case this Technical Bulletin is informational only ²⁾ Code per warranty vendor code policy. ³⁾ Labor Time Units (TUs) are subject to change with ELSA updates. ⁴⁾ Documentation required per Warranty Policy Procedures Manual.			



Technical Bulletin

Please verify engine code for accurate warranty table selection.

To determine if this procedure is covered under Warranty, always refer to the Warranty Policies and Procedures Manual ¹⁾					
Model(s)	Year(s)	Eng. Code(s)	Trans. Code(s)	VIN Range From	VIN Range To
Jetta SportWagen, Golf Wagon	2010-2014	2.0L TDI (CJAA)	All	All	All
SAGA Coding					
Claim Type:	Use applicable Claim Type ¹⁾				
Service Number:	Damage Code	HST		Damage Location (Depends on Service No.)	
2143	0055	--		Use applicable when indicated in ElsaWeb (L/R)	
Parts Manufacturer	Jetta SportWagen, Golf Wagon		3ME ²⁾		
Labor Operation ³⁾ : Replace Charge Air Cooler		21431983 = 20 TU			
Labor Operation ³⁾ : Radiator Remove and Install		19701983 = 70 TU			
Labor Operation ³⁾ : Lock Carrier Service Position		50380950 = 50 TU			
Labor Operation ³⁾ : Remove and Install Front Bumper Cover		63291950 = 40 TU			
Labor Operation ³⁾ : Remove and Install Radiator Grille		66051900 = 20 TU			
Labor Operation ³⁾ : Install Cold Weather Intercooler Kit		21433199 = 30 TU max.			
Causal Part:		1K0 198 803 B			
Diagnostic Time ⁴⁾					
GFF Time expenditure	01500000 = 30 TU max.		YES		
Road Test	01210004 = 10 TU		YES		



Technical Bulletin

Technical Diagnosis	01320000 = 00 TU max.	NO
Claim Comment: Input "As per Technical Bulletin 2025464" in comment section of Warranty Claim.		
¹⁾ Vehicle may be outside any Warranty in which case this Technical Bulletin is informational only ²⁾ Code per warranty vendor code policy. ³⁾ Labor Time Units (TUs) are subject to change with ELSA updates. ⁴⁾ Documentation required per Warranty Policy Procedures Manual.		

Please verify engine code for accurate warranty table selection.

To determine if this procedure is covered under Warranty, always refer to the Warranty Policies and Procedures Manual ¹⁾					
Model(s)	Year(s)	Eng. Code(s)	Trans. Code(s)	VIN Range From	VIN Range To
Beetle, Beetle Convertible	2013-2014	2.0L TDI (CJAA)	All	All	All
SAGA Coding					
Claim Type:		Use applicable Claim Type ¹⁾			
Service Number:	Damage Code	HST		Damage Location (Depends on Service No.)	
2143	0055	--		Use applicable when indicated in ElsaWeb (L/R)	
Parts Manufacturer		Beetle, Beetle Convertible		3ME ²⁾	
Labor Operation ³⁾ : Replace Charge Air Cooler (includes radiator R&I, drain & fill)			21431983 = 160 TU		
Labor Operation ³⁾ : Remove and Install Front Bumper Cover (includes front wheel housing liners loosened + fastened) (Convertible includes noise dampening pan removed + reinstalled)			63291900 = 70 TU – Beetle 63291900 = 110 TU – Beetle Convertible		



Technical Bulletin

Labor Operation ³⁾ : Install Cold Weather Intercooler Kit	21433199 = 30 TU max.	
Causal Part:	1K0 198 803 B	
Diagnostic Time ⁴⁾		
GFF Time expenditure	01500000 = 30 TU max.	YES
Road Test	01210004 = 10 TU	YES
Technical Diagnosis	01320000 = 00 TU max.	NO
Claim Comment: Input "As per Technical Bulletin 2025464" in comment section of Warranty Claim.		
<p>¹⁾ Vehicle may be outside any Warranty in which case this Technical Bulletin is informational only</p> <p>²⁾ Code per warranty vendor code policy.</p> <p>³⁾ Labor Time Units (TUs) are subject to change with ELSA updates.</p> <p>⁴⁾ Documentation required per Warranty Policy Procedures Manual.</p>		

Required Parts and Tools

Part Description	Part No:	Quantity
Cold Weather Intercooler Kit	1K0 198 803 B	1

No Special Tools required.

Additional Information

All part and service references provided in this Technical Bulletin are subject to change and/or removal. Always check with your Parts Dept. and Repair Manuals for the latest information.