

FLA COE
FLB COE
FLD Conventional
Business Class
FLC 112 Conventional

Century Class Conventional
Argosy COE
Cargo
Columbia

122SD and Coronado
Business Class M2
> Cascadia
108SD/114SD

Freightliner
Service Bulletin

Description of Revisions: *This bulletin replaces the version dated November 2014. Part numbers have been added.*

General Information

Some production rear axle s-cam support brackets (11-15990-001) on Cascadia trucks may crack under certain operating conditions. A more robust rear axle s-cam support bracket (11-29558-001) is available if needed. See [Fig. 1](#) for an example of 11-15990-001, and [Fig. 2](#) for an example of 11-29558-001. Either part is acceptable for replacement of a cracked bracket. Use the instructions below to replace the support bracket.

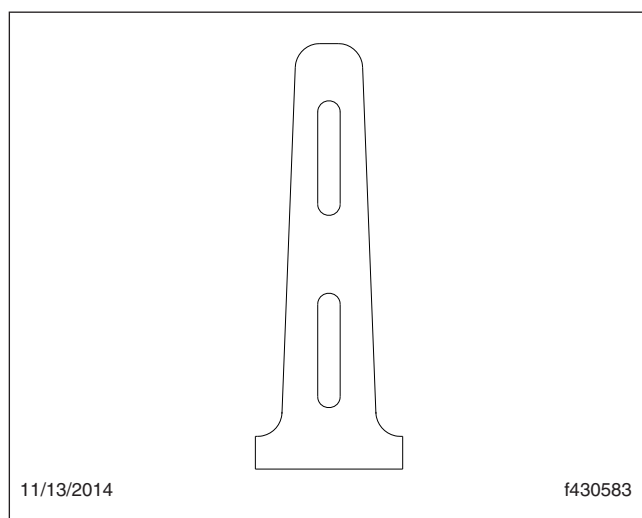

Fig. 1, S-Cam Support Bracket 11-15990-001

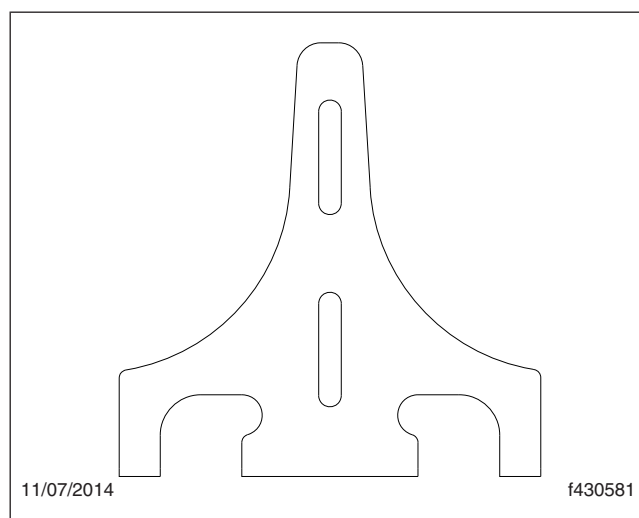

Fig. 2, S-Cam Support Bracket 11-29558-001

Procedure

1. Park the vehicle on a level surface, shut down the engine, and set the parking brake. Chock the tires.
2. Disconnect the batteries.
3. Raise the vehicle, and support the axle with the cracked s-cam bracket with jack stands.
4. Remove the wheels. For instructions, see **Group 40** of the *Cascadia Workshop Manual*.
5. Move any wiring or air lines that may be on or near the bracket.
6. Remove the s-cam tube U-bolts from the bracket.
7. Using a torch or cutoff wheel, carefully remove the s-cam bracket.
8. Using a grinder or sanding wheel, clean off the remaining weld material on the axle housing.
9. Position the new s-cam bracket and install the U-bolts. Be careful not to bend or deform the bracket during installation. For placement of the new bracket, refer to EZWiring™.
10. Weld the top and bottom of the support bracket in the areas shown in [Fig. 3](#).
11. Apply paint to the new bracket.
12. Move any wiring or air lines that were moved earlier to their original position.
13. Install the wheels. For instructions, see **Group 40** of the *Cascadia Workshop Manual*.

Freightliner Service Bulletin

FLA COE
FLB COE
FLD Conventional
Business Class
FLC 112 Conventional

Century Class Conventional
Argosy COE
Cargo
Columbia

122SD and Coronado
Business Class M2
> Cascadia
108SD/114SD

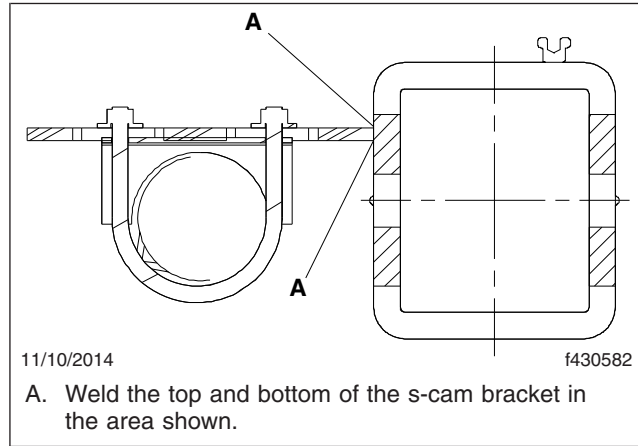

Fig. 3, Welding the S-Cam Support Bracket

14. Remove the jack stands and lower the vehicle.
15. Connect the batteries.

Warranty

This is an informational bulletin only; warranty does not apply.