

REFERENCE:	Nova Bus Manuals
SECTION:	09: Alternator and voltage regulator
RS N°:	MQR 7621-412
EFFECTIVE IN PROD.:	L840 (2014SE)

APPLICATION DEADLINE:NA

SUBJECT:	Alternator in load signal
JUSTIFICATION:	Alternator in load signal may cause malfunction of IO/B V-BEA module

LEVEL	DESCRIPTION	DIRECT CHARGES		TIME
		LABOUR	MATERIAL	
1	Install relay between alternator in load signal and IO/B module	Client	Client	30 min
2	-	-	-	-

**MATERIAL**

QTY	PART N°	REV.	DESCRIPTION	REPLACES PART N°
<b>LEVEL 1</b>				
1	N632000163	-	Wire kit	-
<b>LEVEL 2</b>				
-	-	-	-	-

Materials will be available within 30 days. To order, please contact Prevost Parts by phone at 1-800-771-6682, by fax at 1-888-668-2555 or by email at [prevostparts.commandes@volvo.com](mailto:prevostparts.commandes@volvo.com). Specify document number, quantity of parts required and shipping address.

**DISPOSAL OF PARTS**

REMOVED PARTS ARE:	DISCARDED *	RETAINED	* Dispose of the unused parts and the defective parts in accordance with local environmental standards in effect.
	Yes	-	

**REVISION HISTORY**

REV.	DATE	CHANGE DESCRIPTION	WRITTEN BY
NR	2014JL04	Initial release	Luc Carignan

APPROVED BY:

PAGE 1 OF 4

CLIENT	ORDER	ROAD NUMBER		VIN (2NVY/4RKY...)		QTY
		FROM	TO	FROM	TO	
New York City Transit - New York	L536	1200	1201	S92U793000490	S92U993000491	2
New York City Transit - New York	L545	1202	1289	S92U5A4000001	S92U0A4000098	88
New York City Transit - New York	L608	8000	8014	L82U6B4000047	L82U0B4000061	15
New York City Transit - New York	L620	8015	8074	L82U2B4000062	L82U7B4000123	60
New York City Transit - New York	L621	8075	8089	L82U9B4000124	L82U9B4000138	15
New York City Transit - New York	L643	5895	5895	S92U1B4000143	S92U1B4000143	1
New York City Transit - New York	L670	5770	5894	S92U4C4500024	S92U3B4000242	125
New York City Transit - New York	L681	5896	5283	S92U2C4500023	S92U9C4500195	122
New York City Transit - New York	L692	5284	5363	S92U3C4500158	S92U3D4500274	80

**WARNING**

Follow your internal safety procedures.

**PROCEDURE**

- 1.1. Open the rear battery access door and turn the battery disconnect switch to the **OFF** position.
- 1.2. Open the rear IB panel access door.
- 1.3. Bolt the relay support included in kit N632000163 in position C. See Figure 1.
- 1.4. Disconnect connector **IB-X99B1** from module 54 and remove wire 99-099 from position **09**. Cut the terminal and install heat-shrink tubing at the end of the wire. See Figure 1.
- 1.5. Connect wire 99-1160 in position **09** of connector **IB-X99B1** and connect to module 54.
- 1.6. Remove wire 99-099 from position **J1** of terminal block **IB-TB99A**. Cut the terminal and install heat-shrink tubing at the end of the wire.
- 1.7. Remove the resistance installed between terminal block **IB-TB99A** positions **J** and **K**.
- 1.8. Connect wire 99-1159/WH in terminal block **IB-TB99A** position **J1**. See Figure 1.
- 1.9. Connect wire 99-1158/BK in terminal block **IB-TB99A** position **K1**. See Figure 1.
- 1.10. Connect wire 99-1264/BK in terminal block **IB-TB99A** position **K1**. See Figure 1.

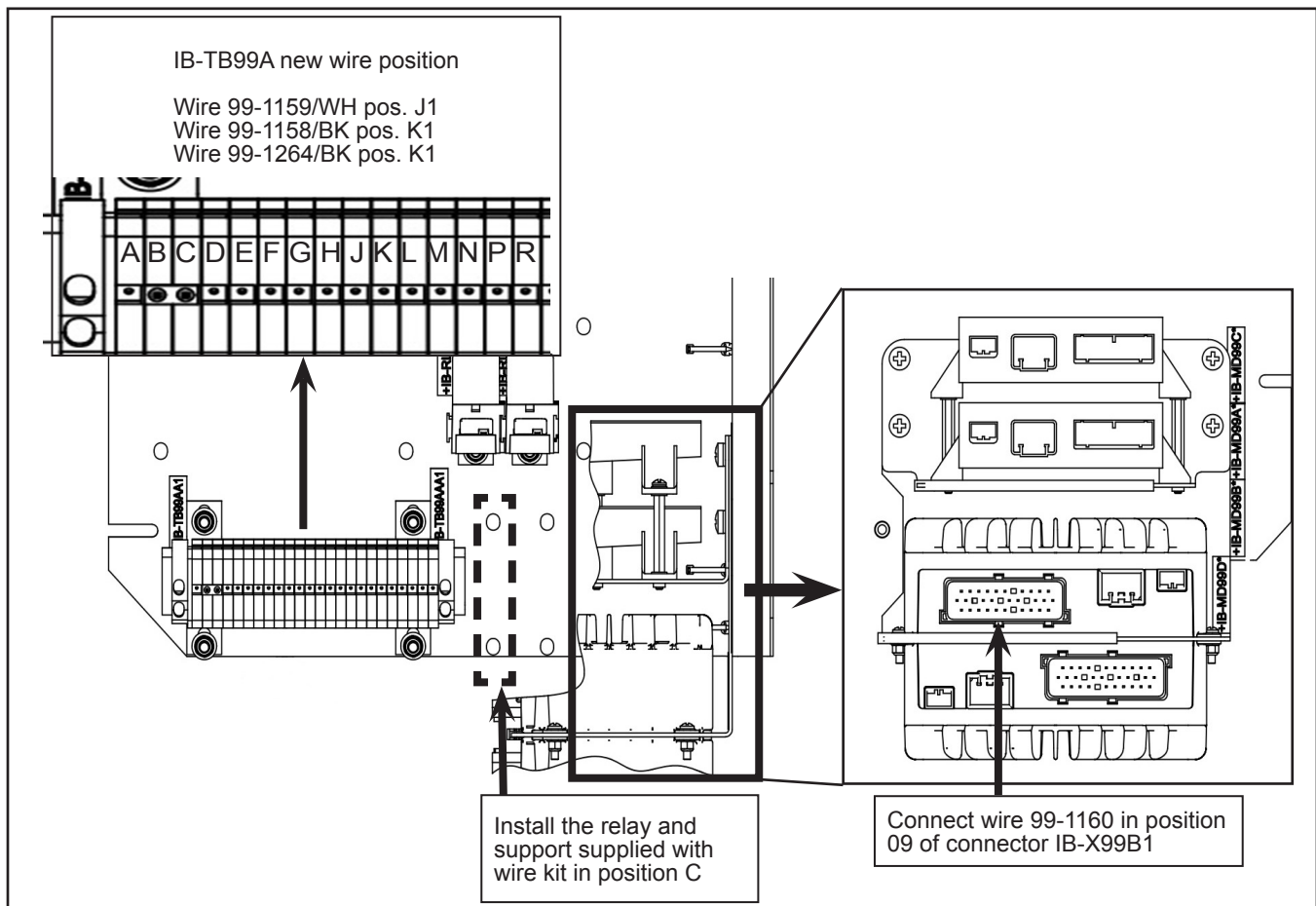

Figure 1 - N632000163 Wire and Relay Position in IB Panel

- 1.11. Connect wire 99-1161/RD in splice connector **IB-SC99B** position **E**. See Figure 2 for wiring diagram of the alternator in load signal.
- 1.12. Turn the battery disconnect switch to the **ON** position and close the rear battery access door.❖

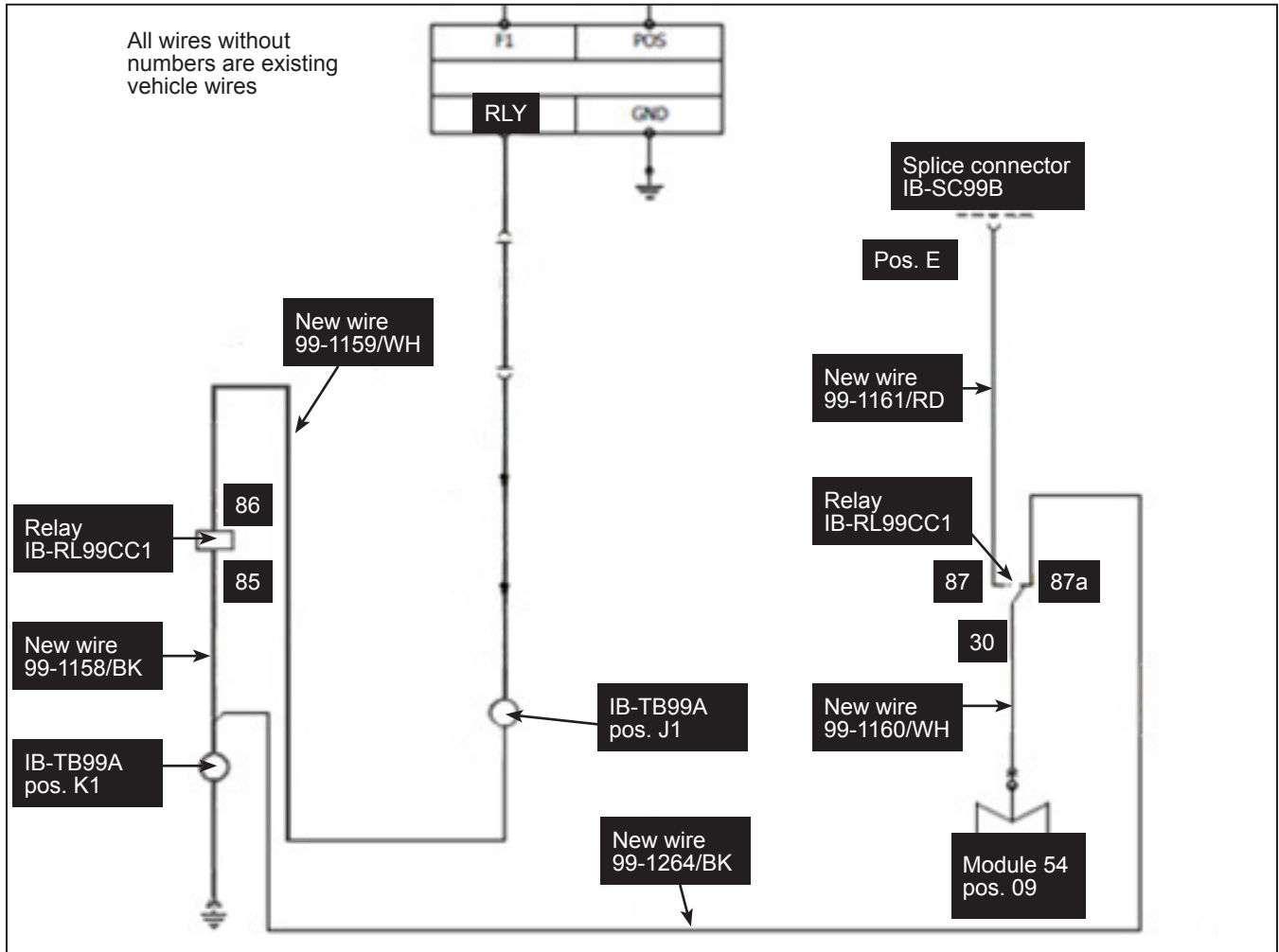

Figure 2 - Wire and Relay Added to Alternator Wiring Diagram