

| | |
|---------------------|--------------------|
| REFERENCE: | Nova Bus Manuals |
| SECTION: | 10 ZF transmission |
| RS N°: | MQR 7621-489 |
| EFFECTIVE IN PROD.: | – |

| |
|-----------------------------------|
| APPLICATION DEADLINE: 2014MA26 |
|-----------------------------------|

| | |
|----------------|--|
| SUBJECT: | ZF transmission breather |
| JUSTIFICATION: | Transmission fluid spills from the transmission breather into the engine compartment |

| LEVEL | DESCRIPTION | DIRECT CHARGES | | TIME |
|-------|---|----------------|----------|--------|
| | | LABOUR | MATERIAL | |
| 1 | Replace for a longer hose and relocate the breather | Nova Bus | Nova Bus | 35 min |
| 2 | – | – | – | – |

MATERIAL

| QTY | PART N° | REV. | DESCRIPTION | REPLACES PART N° |
|----------------|-----------|------|-----------------------------|------------------|
| LEVEL 1 | | | | |
| 1 | 0444042 | | 90-degree elbow F-NPT-3/8 | |
| 1 | 0455863 | | Connector M-FL45-6, M-NPT-6 | |
| 1 | N95706-45 | | Hose assembly | |
| 1 | N40492 | | Bolt M6 20 | |
| 1 | N38593 | | Nut | |
| 1 | N28478 | | Support | |
| 1 | N34423 | | Bolt M8 20 | |
| 2 | 2394308 | | Support | |
| 2 | N32102 | | Bolt M8 25 | |
| 2 | N44888 | | Nut | |
| 2 | N37495 | | two way saddle mount | |
| 2 | N57040 | | Tie cable mount | |
| 6 | N56339 | | Blue tie wrap | |
| 1 | N11121 | | Bolt M8 30 | |
| 4 | N37749 | | Dual-clamp | |
| LEVEL 2 | | | | |
| – | – | – | – | – |

Materials will be available within 60 days. To order, please contact Prevost Parts by phone at 1-800-771-6682, by fax at 1-888-668-2555 or by email at prevostparts.commandes@volvo.com. Specify document number, quantity of parts required and shipping address.

APPROVED BY:

REVISION HISTORY

| REV. | DATE | CHANGE DESCRIPTION | WRITTEN BY |
|------|----------|--|----------------|
| NR | 2013FE15 | Initial release | Wilder Galiano |
| R1 | 2014SE26 | Remove One P-Clamp N31321-02 Add One Tie Cable Mount N57040 Add One Blue Tie Wrap N56339 | Marc Rougeau |

DISPOSAL OF PARTS

| REMOVED PARTS ARE: | DISCARDED * | RETAINED | * Dispose of the unused parts and the defective parts in accordance with local environmental standards in effect. |
|--------------------|-------------|----------|---|
| | Yes | – | |

| CLIENT | ORDER | ROAD NUMBER | | VIN (2NVY/4RKY...) | | QTY |
|----------------------------------|-------|-------------|------|--------------------|---------------|-----|
| | | FROM | TO | FROM | TO | |
| New York City Transit - New York | L643 | 5895 | 5895 | S92U1B4000143 | S92U1B4000143 | 1 |
| New York City Transit - New York | L670 | 5771 | 5894 | S92U9B4000147 | S92U8C4500060 | 124 |
| New York City Transit - New York | L670 | 5770 | 5770 | S92UXC4500061 | S92UXC4500061 | 1 |
| New York City Transit - New York | L681 | 5896 | 5986 | S92U2C4500023 | S92U9C4500164 | 91 |
| New York City Transit - New York | L681 | 5253 | 5283 | S92U0C4500165 | S92U9C4500195 | 31 |
| New York City Transit - New York | L692 | 5284 | 5355 | S92U3C4500158 | S92U4D4500266 | 72 |

**WARNING**

Follow your internal safety procedures.

PROCEDURE

- 1.1. Remove the transmission access panel located at the rear interior of the vehicle. Retain the hardware. See Figure 1.
- 1.2. Open the two-place seat from the rear five-seat.

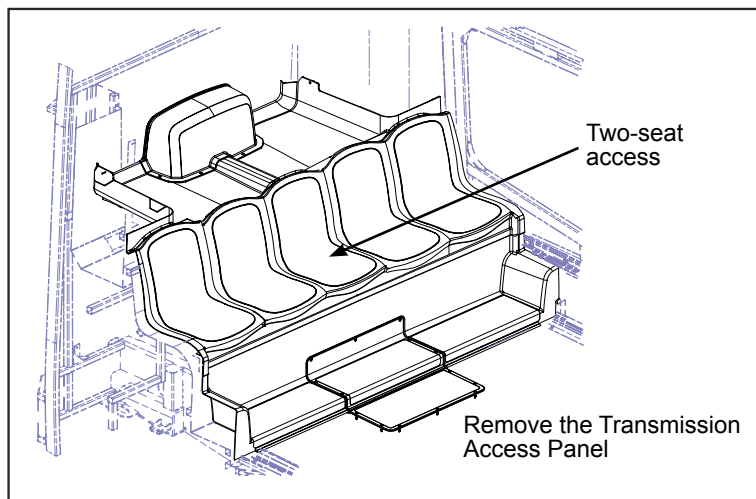

Figure 1 - Transmission Access Panel and Five Seat Location

- 1.3. Locate and remove the installed transmission breather and support from the transmission. See Figure 2. Retain the breather, the breather connector and discard the other components.

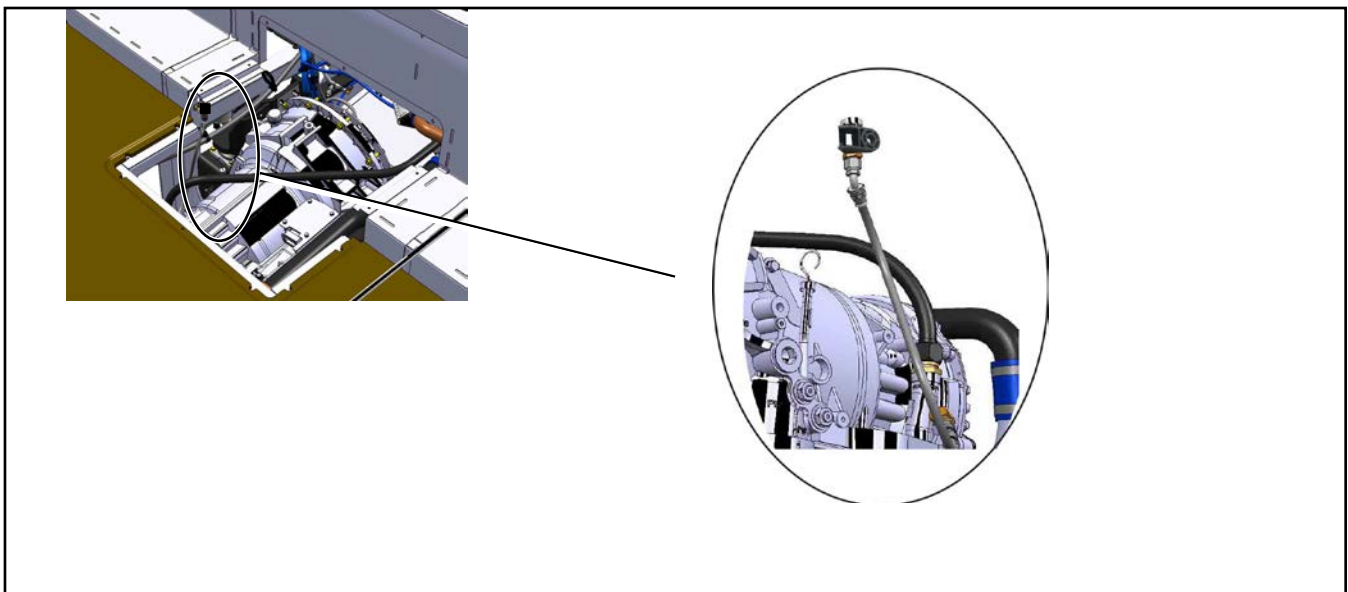

Figure 2 - Installed Transmission Breather Assembly

- 1.4. Install the 0444042 90-degree elbow. Apply white thread sealer, Loctite 565, or equivalent. See Figure 3.
- 1.5. Install the 0455863 connector onto the 90-degree elbow. Apply thread locker.

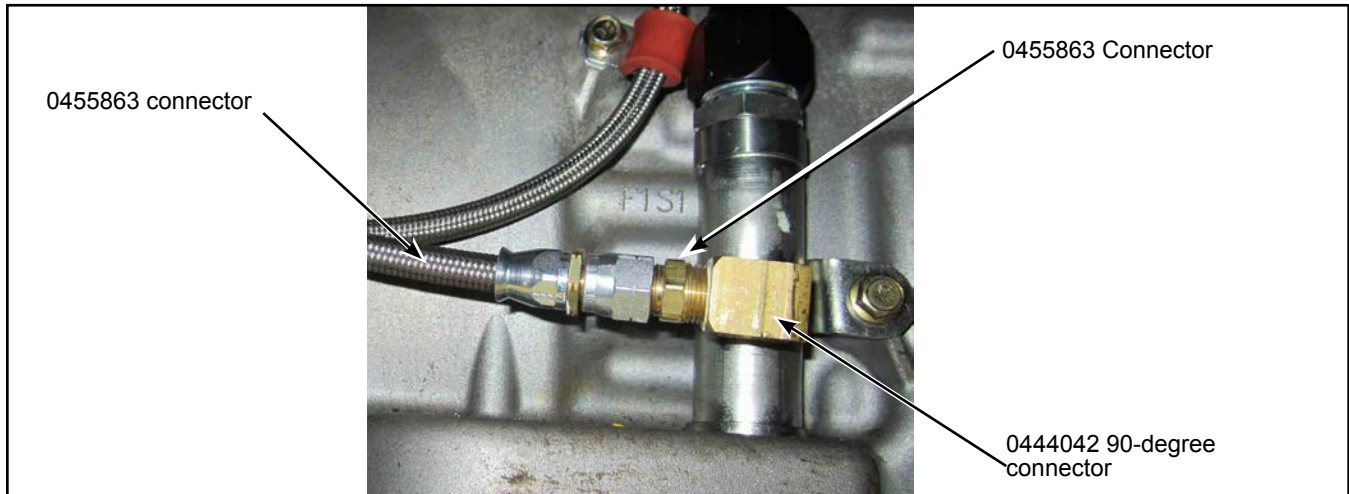

Figure 3 - Hose Connection

- 1.6. Install the N95706-45 hose assembly onto the connector. Apply white thread sealer, Loctite 565, or equivalent.
- 1.7. Coil the hose assembly as shown in Figure 4.



Figure 4 - Hose Coiling

- 1.8. Install the 2394308 support with one N34423 Bolt. See Figure 5.
- 1.9. Install two N31321-01 P-clamps with one N32102 bolt and N44888 nut as indicated in Figure 5.

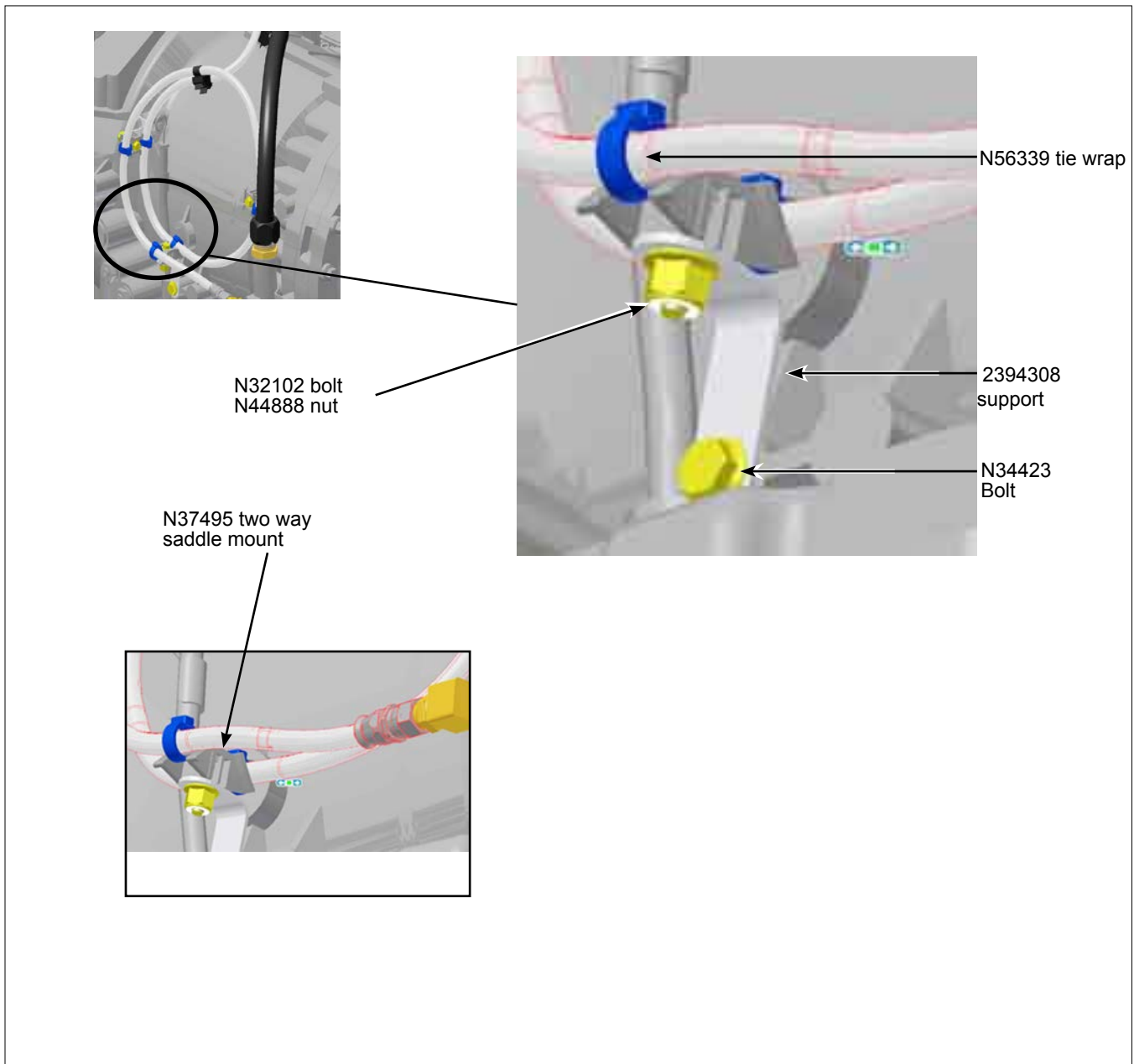

Figure 5 - Affixing the Lower Portion of the Hose

1.10. Install the 2394308 support with the existing transmission dip stick tube retaining bolt. See Figure 6.

1.11. Install one N37495 two way saddle mount with one N32102 bolt and N44888 nut as specified in Figure 6

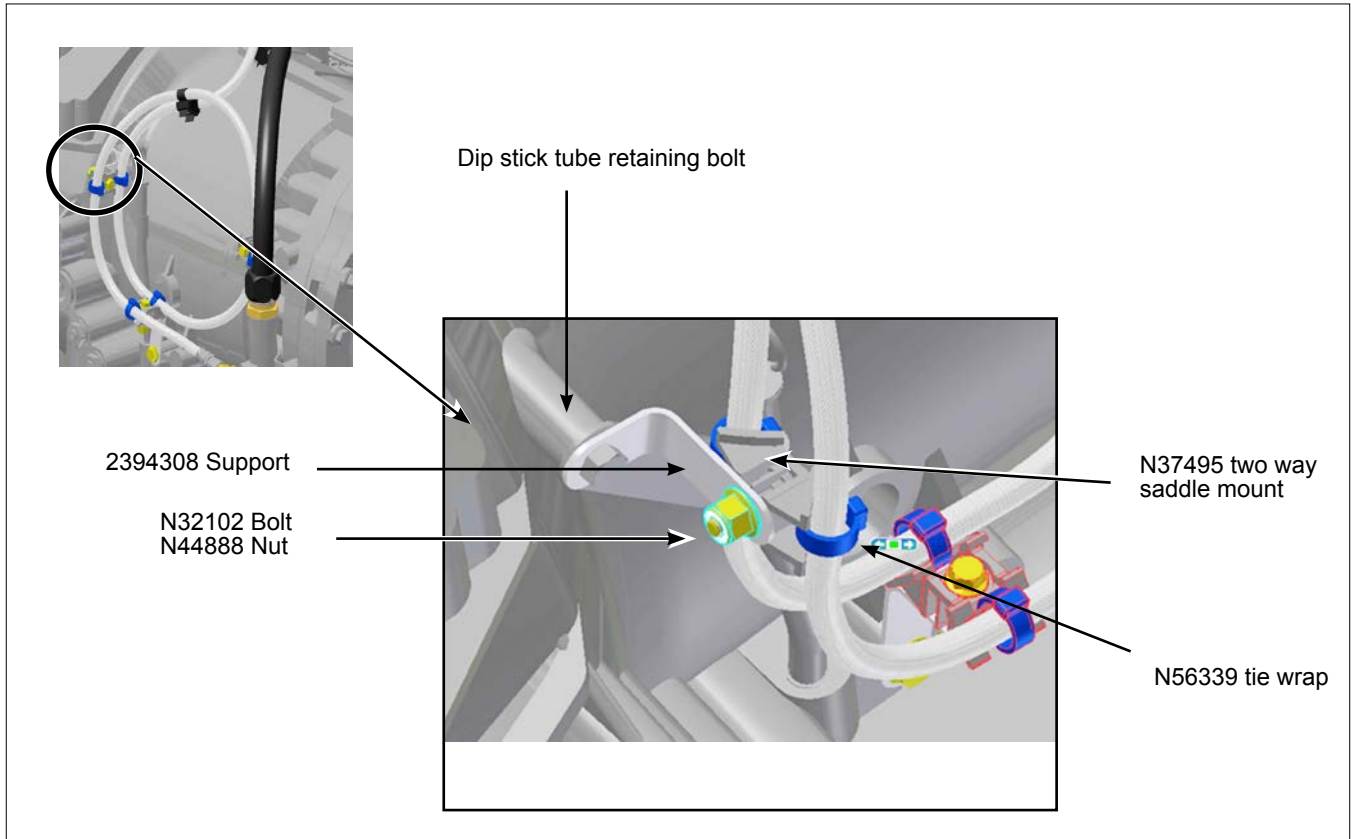

Figure 6 - Affixing the Upper Portion of the Hose

1.12. Install one N57040 tie cable mount with one N11121 as indicated in Figure 7.

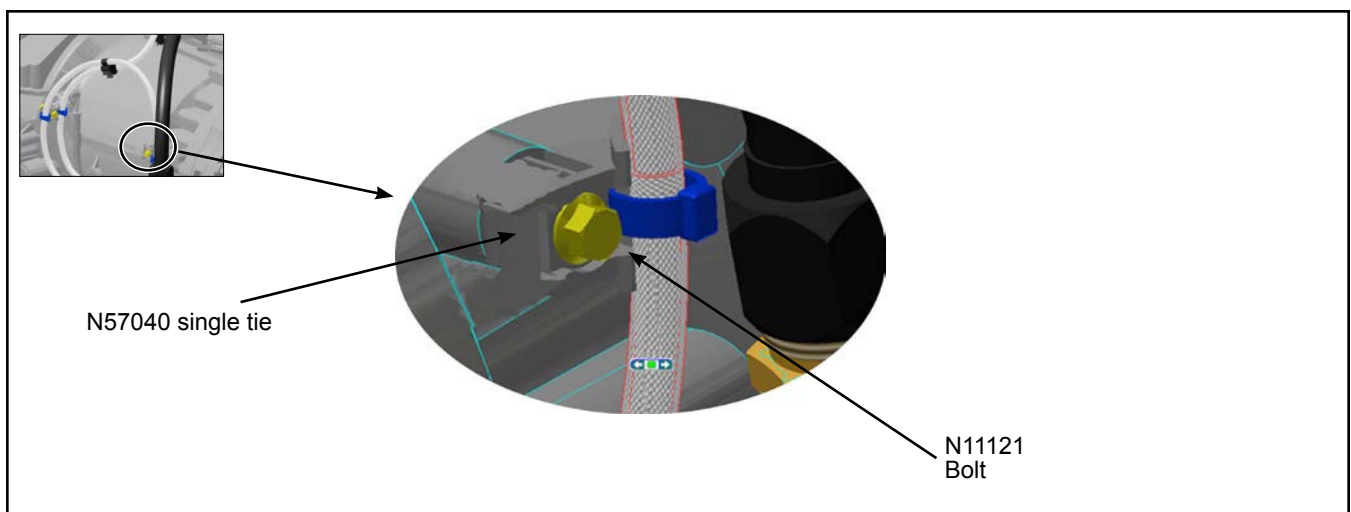

Figure 7 - Affixing the Upper Front Portion of the Hose

1.13. Install four dual -clamps as illustrated in Figure 8.

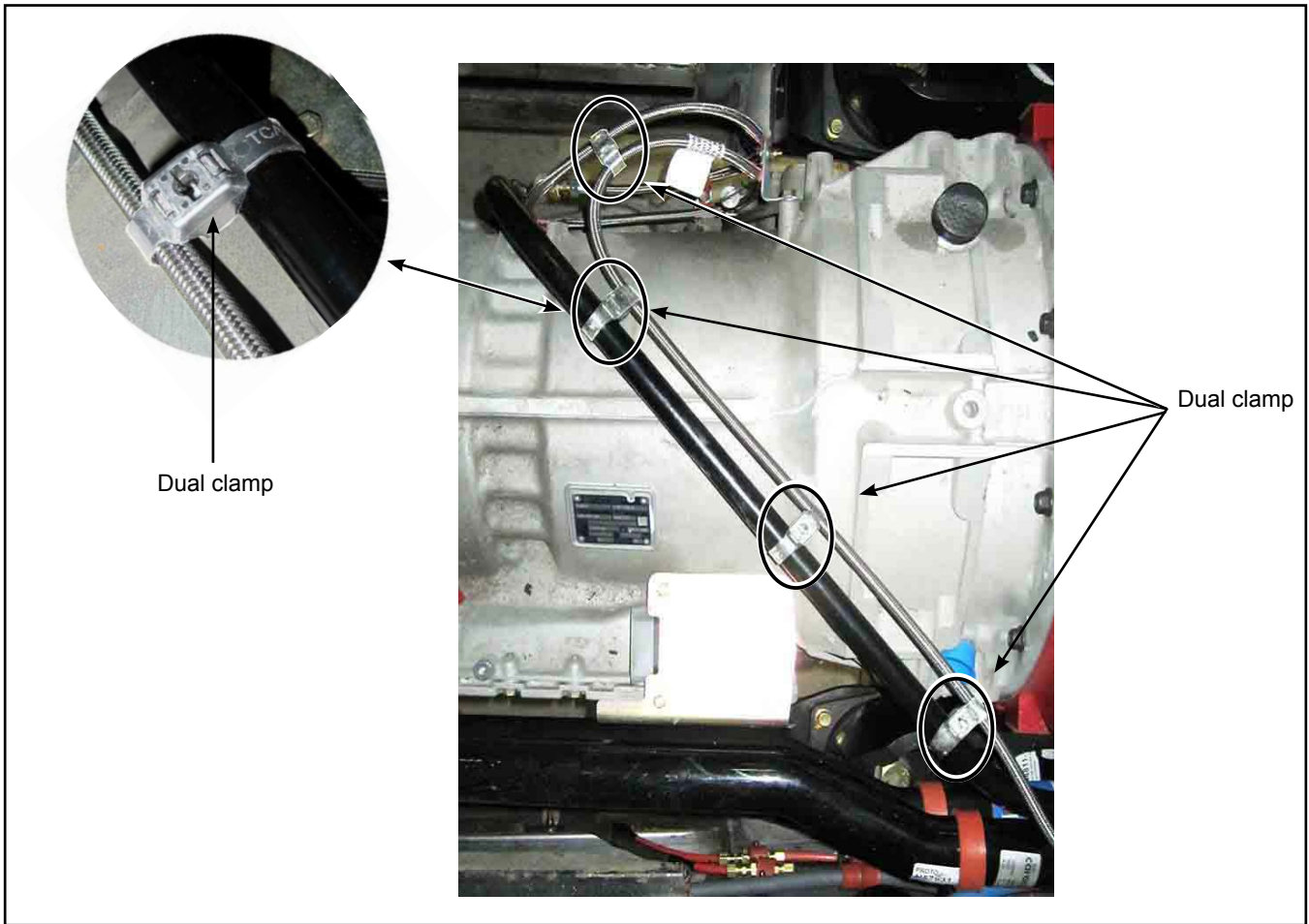

Figure 8 - Dual Clamp Locations

- 1.14. Install the retained connector to the N95706-45 assembly hose. Apply white thread sealer, Loctite 565, or equivalent. See Figure 9.
- 1.15. Install the retained breather to the connector. Apply white thread sealer, Loctite 565, or equivalent.

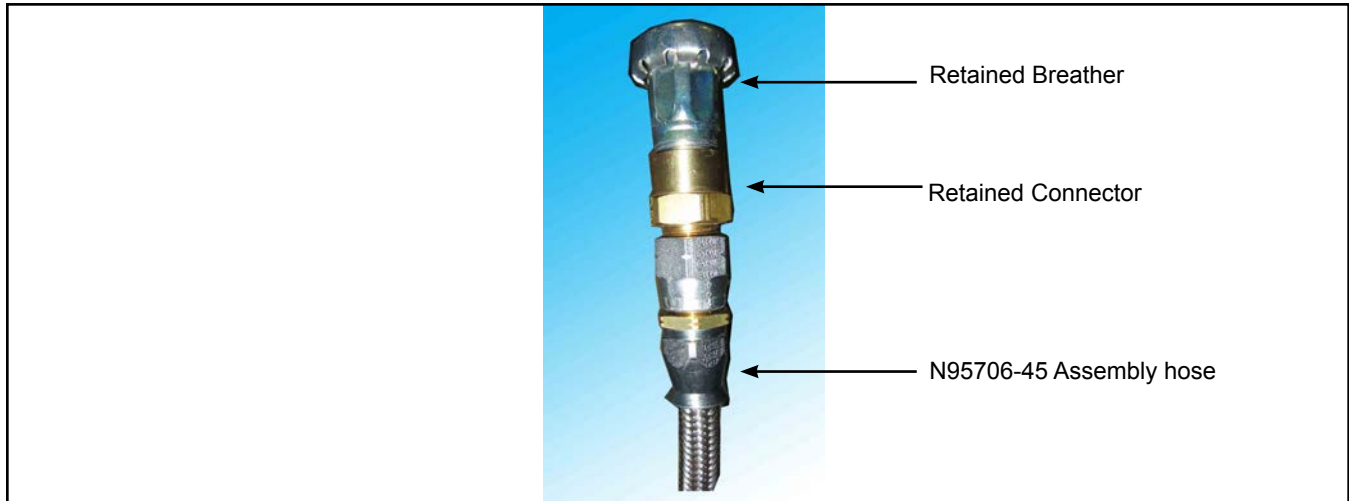

Figure 9 - Connector Installed on Assembly Hose

- 1.16. Install one N57040 Tie cable mount and N56339 blue tie wrap around the breather. See Figure 10.
- 1.17. Install the N28478 support to the Tie cable mount with one N40492 bolt and N38593 nut. See Figure 10.

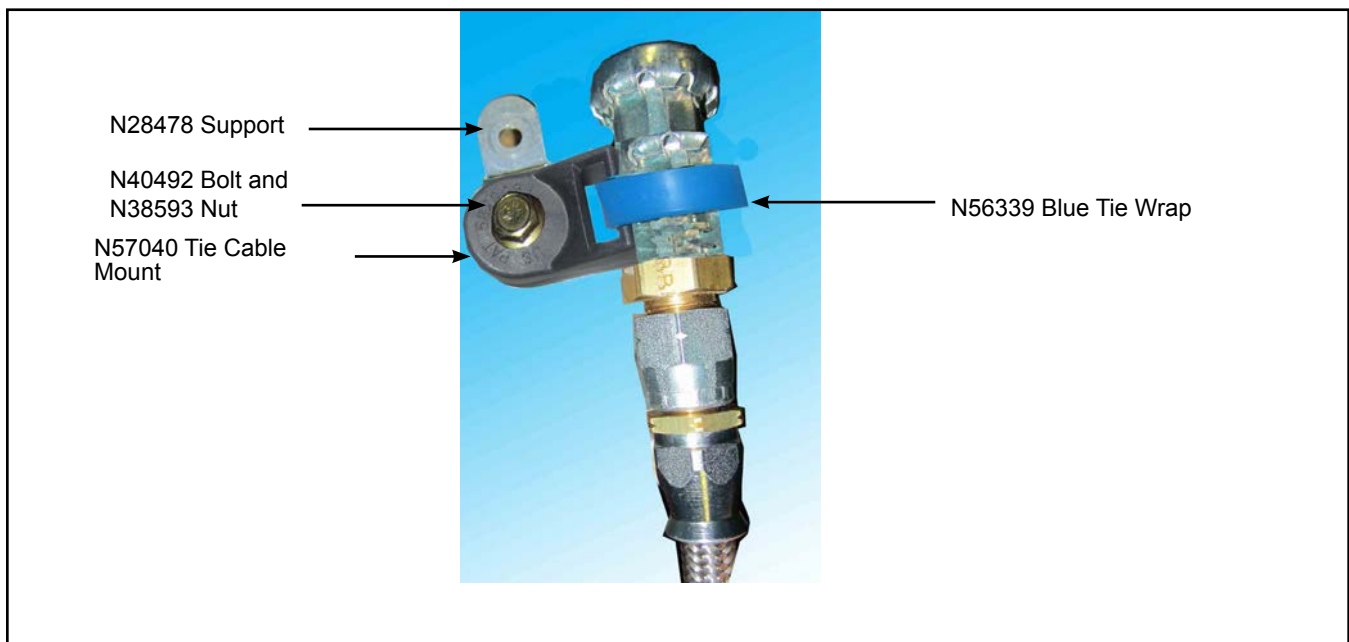

Figure 10 - Tie Cable Mount and blue tie wrap Installed on Breather.

1.18. Install the assembly as shown in Figure 11. Access will be easier from the two-seat opening.

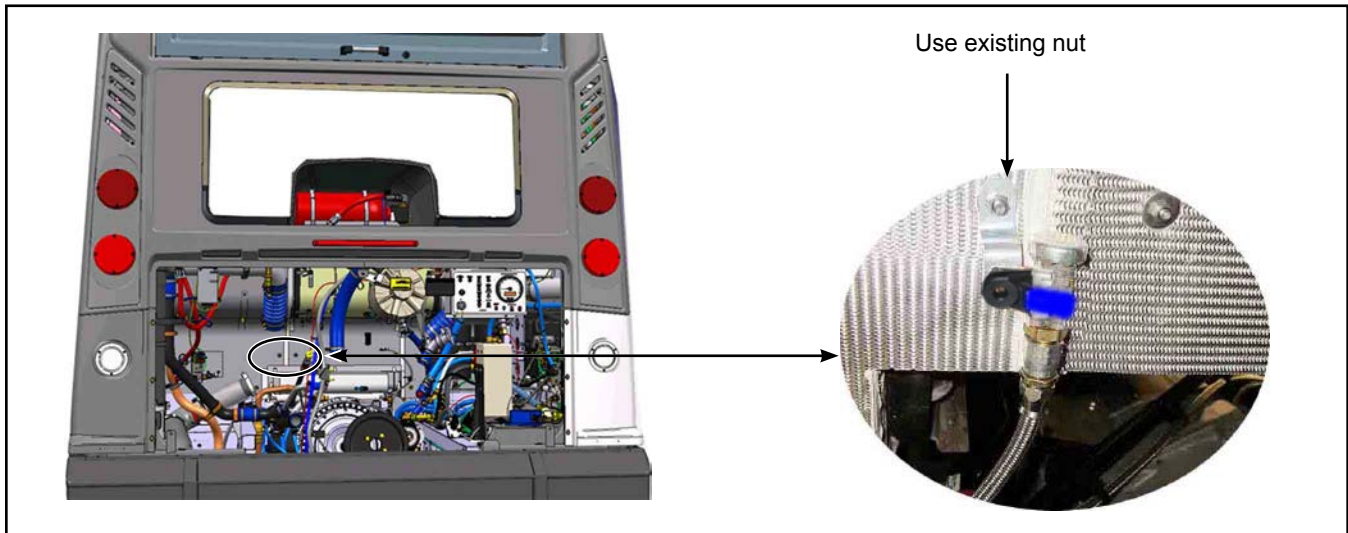

Figure 11 - Installation in Engine Compartment

1.19. Install the transmission access panel with the retained hardware.

1.20. Install the two-place seat from the rear five-seat with the retained hardware.

1.21. Vehicle can be returned to service. ❖