

SERVICE PROCEDURE

13517
MARCH 2014

SUBJECT: SAFETY RECALL
Chassis skirt to fuel tank interference on certain ProStar[®] models with feature codes 0016XSA, 0016XSB, 0016XSC, or 0016XSD built 12 December 2012 through 08 August 2013.

DEFECT DESCRIPTION

During vehicle operation, the rear chassis skirt upper horizontal support S-bracket may contact the fuel tanks during frame twist, and it is possible for the bracket to wear a hole in the top of the fuel tank, which may result in a fuel leak. A hole at the top of the fuel tank may allow fuel to spill on the roadway, which may cause a slippery road condition. This would increase the risk of a motor vehicle crash, which may result in property damage, personal injury, or death.

MODELS INVOLVED

ProStar[®] Sleepers with SCR and Chassis Skirts (Feature Codes 0016XSA, 0016XSB, 0016XSC, 0016XSD)

PARTS INFORMATION

NOTE: The scope of this campaign requires an initial spacer kit and POTENTIALLY intermediate bracket P/N 3989265C5 (x3, nuts) in the event 11 mm clearance is not achieved after shimming. Because the scope of vehicles requiring this bracket is very narrow (2% of the total suspect population), DO NOT preorder intermediate brackets for inventory, and only order when their use is deemed absolutely necessary.

Part Number	Part Description	Quantity
8900247R92	Kit, Skirt Shim, Right Side	1
8900248R92	Kit, Skirt Shim, Left Side	1
3989265C5	Support Bracket 2.0 Weldment	As required

8900247R92 Right Side includes the following parts:

Part Description	Quantity
Spacer, Rail Two Hole	2
Spacer, Frame	1
Spacer, Rail One Hole	2

8900248R92 Left Side includes the following parts:

Part Description	Quantity
Spacer, Rail Two Hole	2
Spacer, Frame	1

SERVICE PROCEDURE

WARNING! PARK VEHICLE ON HARD FLAT SURFACE, TURN THE ENGINE OFF, SET THE PARKING BRAKE, AND INSTALL WHEEL CHOCKS TO PREVENT THE VEHICLE FROM MOVING IN BOTH DIRECTIONS. FAILURE TO COMPLY MAY RESULT IN PROPERTY DAMAGE, PERSONAL INJURY, AND / OR DEATH.

WARNING! IF THE VEHICLE MUST BE RAISED, DO NOT WORK UNDER THE VEHICLE SUPPORTED ONLY BY JACKS. JACKS CAN SLIP OR FALL OVER, POTENTIALLY RESULTING IN PROPERTY DAMAGE, PERSONAL INJURY AND / OR DEATH.

WARNING! ALWAYS WEAR SAFE EYE PROTECTION WHEN PERFORMING VEHICLE MAINTENANCE. FAILURE TO COMPLY MAY RESULT IN PERSONAL INJURY AND / OR DEATH.

WARNING! ALLOW COMPONENTS IN ENGINE COMPARTMENT TO COOL BEFORE SERVICING ENGINE OR VEHICLE. FAILURE TO COMPLY MAY RESULT IN PROPERTY DAMAGE, PERSONAL INJURY AND / OR DEATH.

WARNING! KEEP FLAMES OR SPARKS AWAY FROM VEHICLE AND DO NOT SMOKE WHILE SERVICING THE VEHICLE'S BATTERIES, WHICH EXPEL EXPLOSIVE GASES. FAILURE TO COMPLY MAY RESULT IN PROPERTY DAMAGE, PERSONAL INJURY, AND / OR DEATH.

WARNING! REMOVE THE GROUND CABLE FROM THE NEGATIVE TERMINAL OF THE BATTERY BOX BEFORE DISCONNECTING ANY ELECTRICAL COMPONENTS. ALWAYS CONNECT THE GROUND CABLE LAST. FAILURE TO COMPLY MAY RESULT IN PROPERTY DAMAGE, PERSONAL INJURY, AND / OR DEATH.

NOTE: Steps and graphics depicted in this document are performed on operator side. Consider passenger side typical unless noted.

1. Bring vehicle into shop and park on flat surface.
2. Shift transmission to Park or Neutral, set parking brakes, and install wheel chocks.

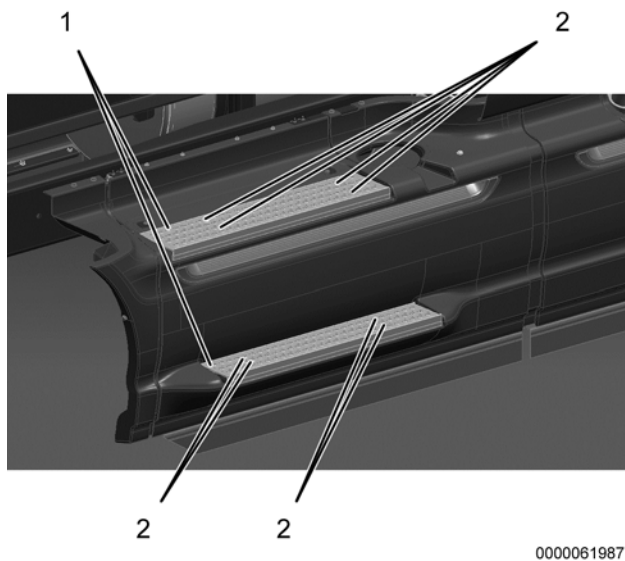
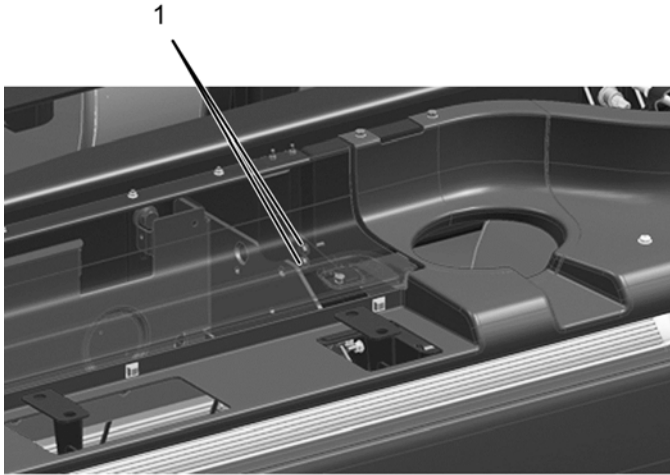

Figure 1. Front Skirt Panel Assembly.

1. Step (2)
2. M8 bolt (8)

3. Remove upper and lower steps (Figure 1, Item 1) from front skirt panel assembly, by removing eight bolts (Figure 1, Item 2).



000083982

Figure 2. Operator-Side Front Skirt Panel Bracket.

1. M8 bolt (2)

4. Remove two bolts (Figure 2, Item 1) from front skirt panel bracket.

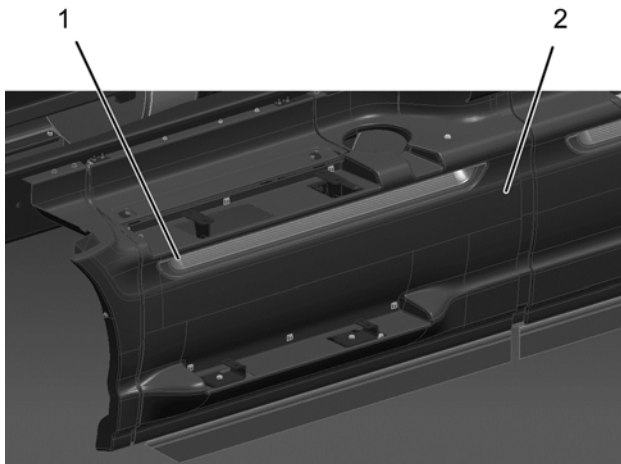

000061988

Figure 3. Pocket Molding Panel.

1. Pocket molding panel
2. Front skirt panel assembly

5. Remove pocket molding panel (Figure 3, Item 1) from front skirt panel assembly (Figure 3, Item 2).

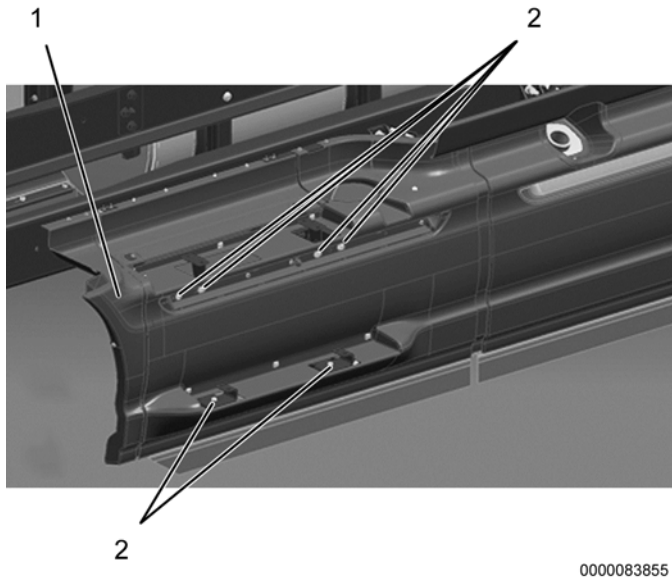

0000083855

Figure 4. Front Skirt Panel Assembly.

1. Front skirt panel assembly
2. M8 bolt (6)

NOTE: The passenger side front skirt panel requires removal of five M8 bolts opposed to the six M8 bolts shown on the operator side.

6. Remove six bolts (Figure 4, Item 2) from front skirt panel assembly (Figure 4, Item 1).
7. Remove front skirt panel assembly (Figure 4, Item 1).

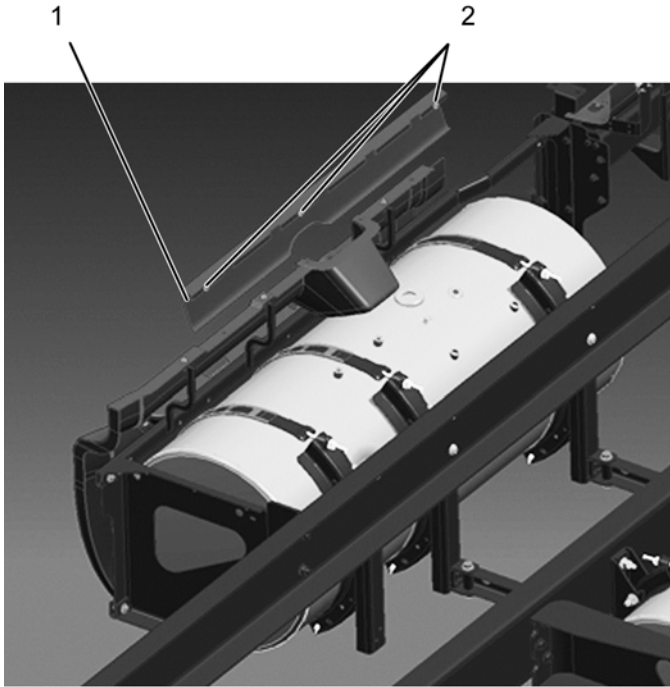

0000084084

Figure 5. Sleeper Modesty Panel.

1. Sleeper modesty panel
2. M6 bolt (3)

8. Remove three bolts (Figure 5, Item 2) from sleeper modesty panel (Figure 5, Item 1).
9. Remove sleeper modesty panel (Figure 5, Item 1) from sleeper.

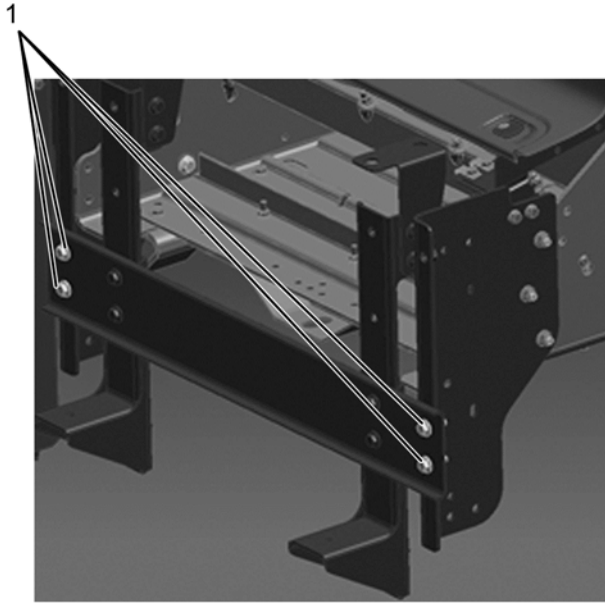

0000291310

Figure 6. Skirt Bracket Assembly.

1. M10 bolt (4)

NOTE: Following step for units equipped with a DEF tank located on the operator side of the vehicle.

10. Remove four bolts (Figure 6, Item 1) from skirt bracket assembly.

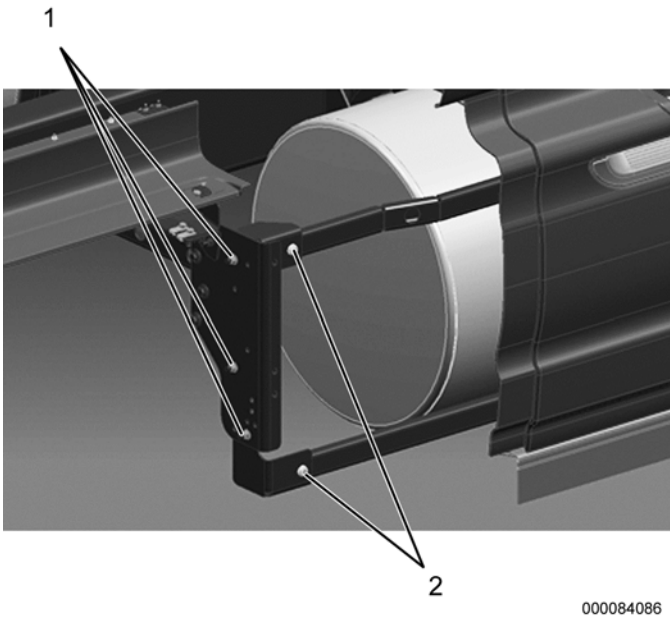

Figure 7. Rear Skirt Assembly.

1. M10 nut (3)
2. M10 bolt (2)

NOTE: Following step for units equipped with a DEF tank located on the operator side of the vehicle.

11. Remove two bolts (Figure 7, Item 2) from front of rear skirt bracket.

12. Remove three nuts (Figure 7, Item 1) from front of rear skirt assembly.

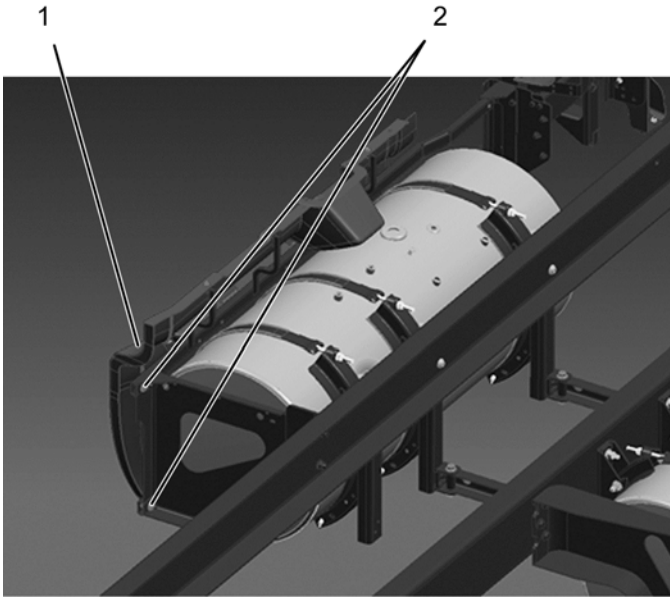

0000084088

Figure 8. Operator-Side Rear Skirt Assembly.

1. Operator-side rear skirt assembly
2. M10 nut (3) (1 not shown)

NOTE: Discard any round steel washers being used as spacers between the rail and stanchion outer face. DO NOT discard washers used with attaching nuts.

13. Remove three nuts (Figure 8, Item 2) from rear of rear skirt assembly (Figure 8, Item 1).

14. Remove rear skirt assembly (Figure 8, Item 1).

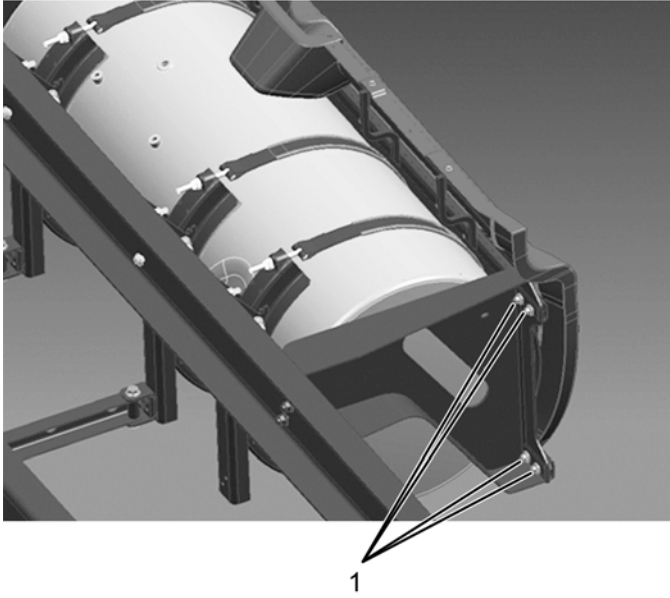

0000084104

Figure 9. Passenger-Side Rear Skirt Assembly.

1. M10 nut (4)

NOTE: For units equipped with blind spot detector, temporarily disconnect wiring harness from rear of blind spot detector.

15. Remove four nuts (Figure 9, Item 1) from rear of passenger-side rear skirt assembly.
16. Remove passenger-side rear skirt assembly.

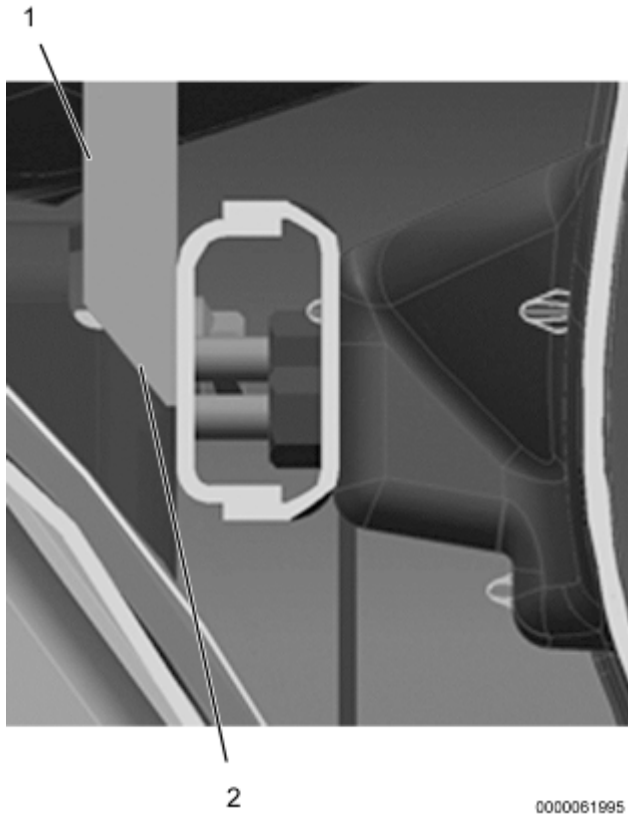
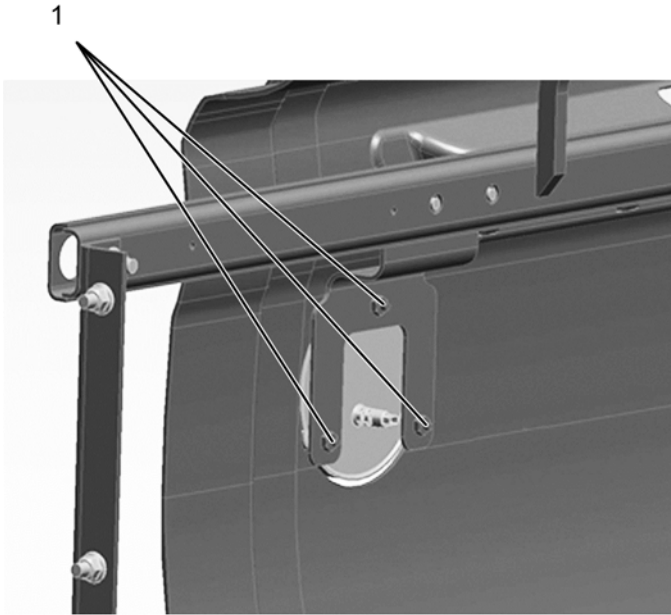

Figure 10. S-Bracket Chamfer.

1. S-bracket (3) (2 not shown)
2. 45° chamfer

17. Using a grinder, add 45° chamfer (Figure 10, Item 2) to all S-brackets (Figure 10, Item 1) on upper horizontal support rail.
18. Paint cut surface of S-brackets.
19. If observed, document fuel tank concerns with photographs and descriptions, and proceed to replacement of fuel tank if required. Refer to [AFC12928](#) for fuel tank removal and installation procedures.



0000137333

Figure 11. Passenger-Side Blind Spot Detector Attachment Points.

1. Bolt (3)

20. Grind attachment bolts (Figure 11, Item 1) down to show a minimum of three exposed threads.

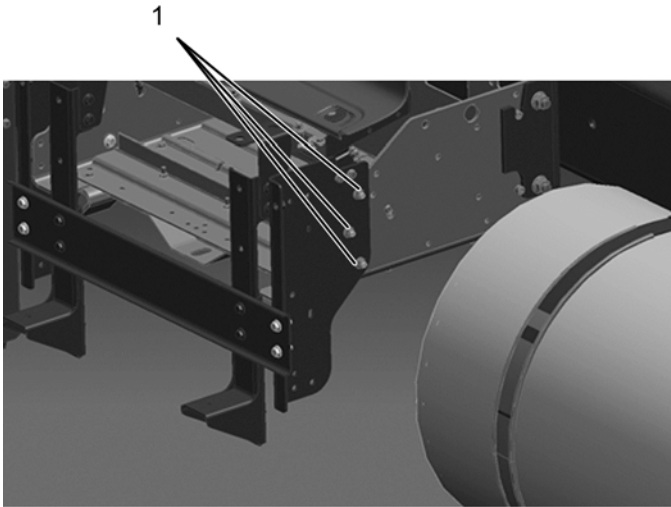

0000084091

Figure 12. Intermediate Bracket Adjustment.

1. M10 bolt (3)

21. Loosen three M10 bolts (Figure 12, Item 1) from intermediate bracket.
22. Adjust intermediate bracket up and outboard as much as possible.
23. Using torque wrench, tighten three M10 bolts (Figure 12, Item 1) to 37 lb-ft (50 N·m).

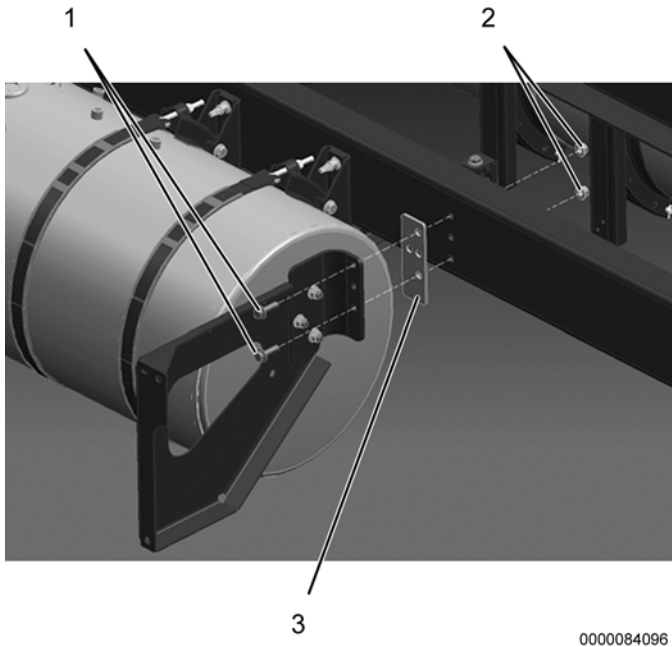

Figure 13. Frame Stanchion Spacer.

1. M14 bolt (3) (1 not shown)
2. Nut (3) (1 not shown)
3. 4040097C1 Frame Spacer

24. Remove three bolts and nuts (Figure 13, Items 1 and 2) from frame stanchion.

25. Position stanchion away from frame, and install frame spacer (Figure 13, Item 3) with three bolts and nuts (Figure 13, Items 1 and 2). Using torque wrench, tighten three bolts and nuts to 100 lb-ft (127 N·m).

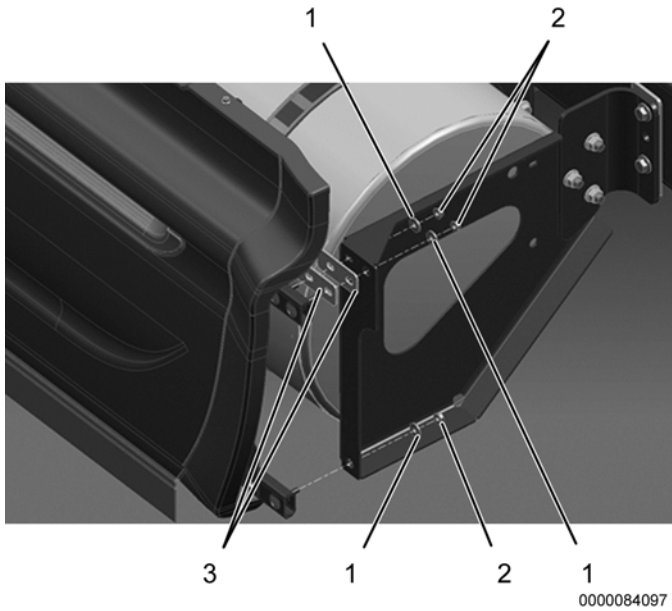

Figure 14. Operator-Side Rear Skirt Assembly.

1. Washer (3)
2. M10 nut (3)
3. 4038093C1 Rear Skirt Spacer (2)

26. Install rear skirt assembly with two spacers (Figure 14, Item 3), and install three nuts with washers (Figure 14, Items 1 and 2) onto rear of rear skirt assembly. Using torque wrench, tighten three nuts to 37 lb-ft (50 N·m).

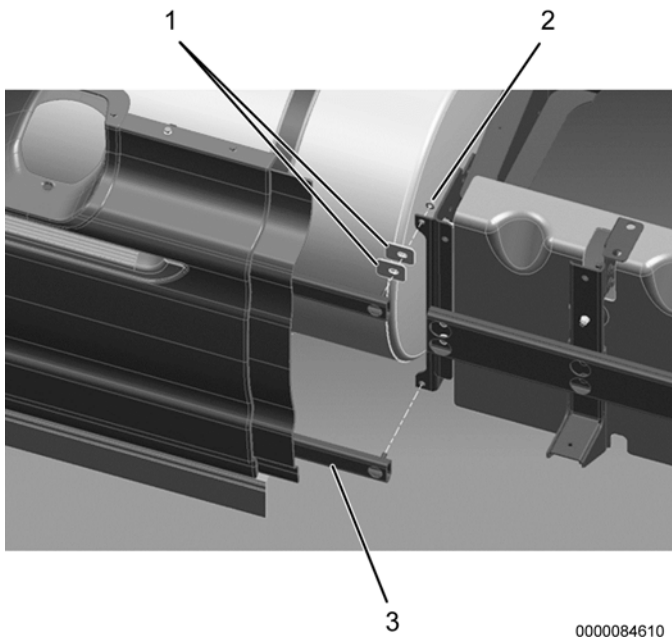

Figure 15. Passenger-Side Rear Skirt Assembly.

1. 4038097C1 Rear Skirt Spacer (2)
2. M10 nut (2, 1 not shown)
3. Rear skirt assembly

NOTE: For units equipped with blind spot detector, connect wiring harness to rear of blind spot detector.

27. Install rear skirt assembly (Figure 15, Item 3) to front vertical support with two spacers (Figure 15, Item 1), and install two original nuts (Figure 15, Item 2) onto rear of rear skirt assembly. Using torque wrench, tighten two nuts to 37 lb-ft (50 N·m).

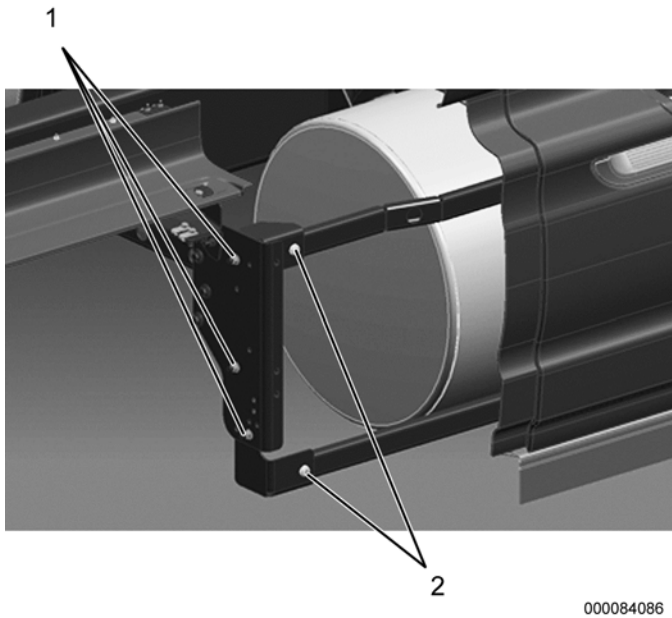

Figure 16. Operator-Side Rear Skirt Assembly.

1. M10 nut (3)
2. M10 bolt (2)

28. Install three nuts (Figure 16, Item 1). Using torque wrench, tighten three nuts onto front of rear skirt assembly to 37 lb-ft (50 N·m).

NOTE: Following step for units equipped with a DEF tank located on the operator side of the vehicle.

29. Install two bolts (Figure 16, Item 2) onto front of rear skirt bracket. Using torque wrench, tighten two bolts onto front of rear skirt assembly to 37 lb-ft (50 N·m).

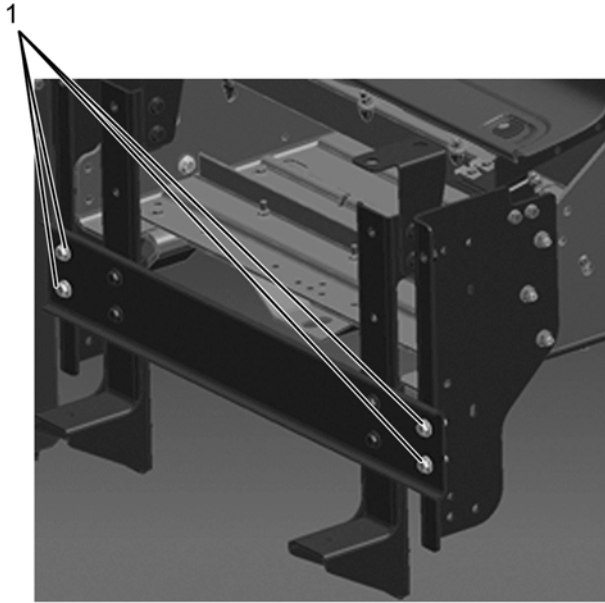

0000291310

Figure 17. Skirt Bracket Assembly.

1. M10 bolt (4)

NOTE: Following step for units equipped with a DEF tank located on the operator side of the vehicle.

30. Install four bolts (Figure 17, Item 1) onto skirt bracket assembly. Using torque wrench, tighten bolts to 37 lb-ft (50 N·m).

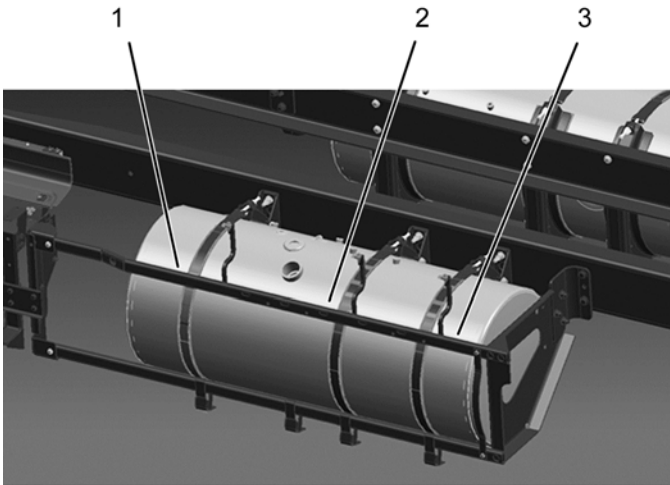

0000084095

Figure 18. Rear Skirt Measurement Points.

1. Front rail to fuel tank (forward of S-bracket and tank strap)
2. Rear rail to fuel tank (forward of S-bracket)
3. Rear rail to fuel tank (aft of S-bracket and tank strap)

NOTE: Skirt removed from graphic for clarity.

31. Using 11 mm feeler gauge or equivalent, measure distance between fuel tank and upper horizontal support rail. Measurements should be taken and noted at the following points:

- Front rail to fuel tank (forward of S-bracket and tank strap, Figure 18, Item 1)
- Rear rail to fuel tank (forward of S-bracket, Figure 18, Item 2)
- Rear rail to fuel tank (aft of S-bracket and tank strap, Figure 18, Item 3)

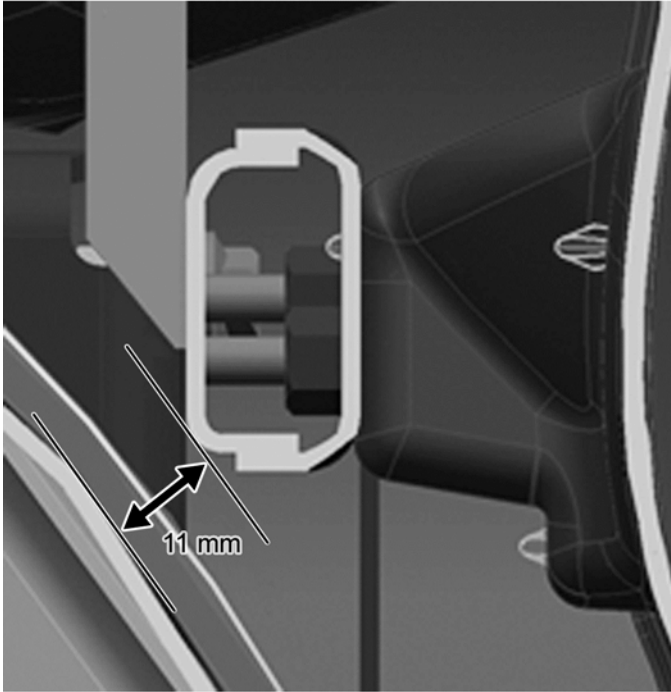

000084093

Figure 19. Chassis Skirt Rail to Fuel Tank Measurement Cross Section.

32. Follow steps below for instructions regarding chassis skirt rail to fuel tank clearance measurement (Figure 19).

- If all points measure above 11 mm, proceed to Step 33, and continue reassembly.
- If operator or passenger side front measurement is below 11 mm, order and install intermediate bracket P/N 3989265C5 Bracket 2.0 Weldment.
- Remove old intermediate bracket.
- Install three M10 bolts, three washers, and three nuts to new intermediate bracket.
- Install two M8 bolts, two nuts, and two washers to new intermediate bracket. Using torque wrench, tighten to 18 lb-ft (25 N·m).

- Adjust new bracket up and outboard as far as possible. Once positioned, use a torque wrench to tighten three M10 bolts, washers and nuts to 37 lb-ft (50 N·m).
- Reassemble rear skirt (Steps 26 - 31).
- Re-measure (Step 32) to confirm 11 mm minimum gap (Figure 19), and then proceed to next step.

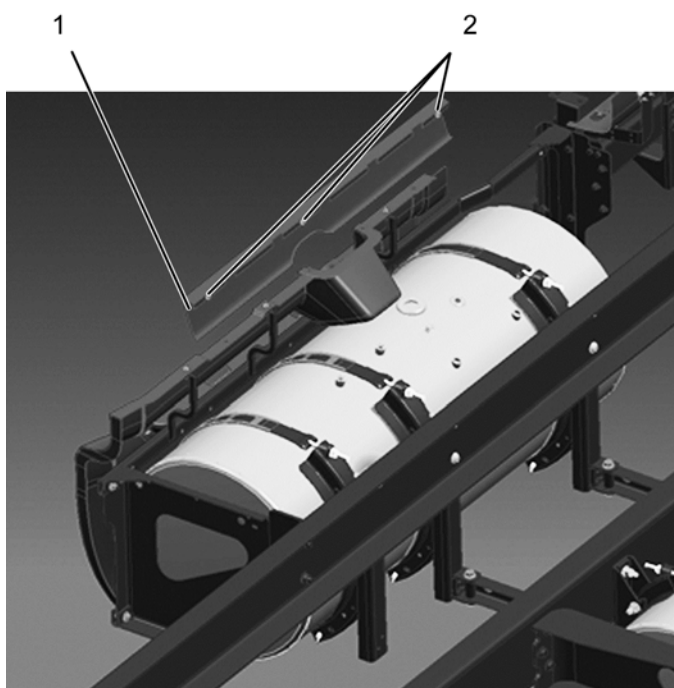

0000084084

Figure 20. Sleeper Modesty Panel.

1. Sleeper modesty panel
2. M6 bolt (3)

33. Position sleeper modesty panel (Figure 20, Item 1) onto sleeper and install three bolts (Figure 20, Item 2) onto sleeper modesty panel.
34. Using torque wrench, tighten three bolts (Figure 20, Item 2) onto sleeper modesty panel (Figure 20, Item 1) to 8 lb-ft (11 N·m).

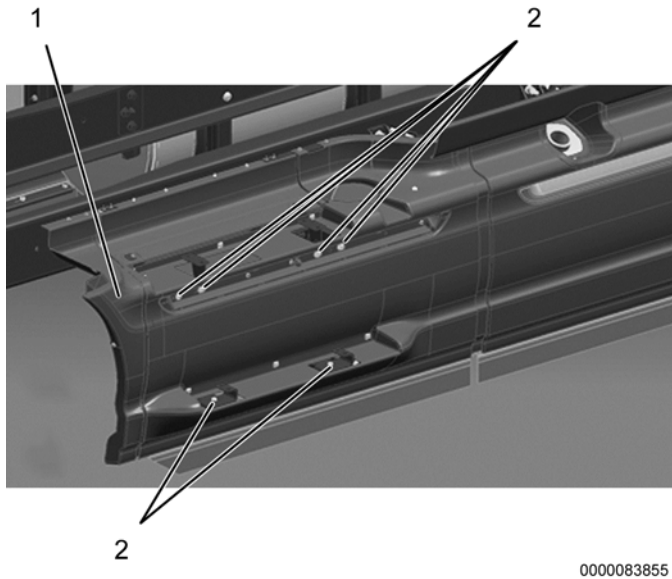

0000083855

Figure 21. Front Skirt Panel Assembly.

1. Front skirt panel assembly
2. M10 bolt (6)

35. Install front skirt panel assembly (Figure 21, Item 1).

36. Install six bolts (Figure 21, Item 2) onto front skirt panel assembly (Figure 21, Item 1).

37. Using torque wrench, tighten six bolts (Figure 21, Item 2) to 37 lb-ft (50 N·m).

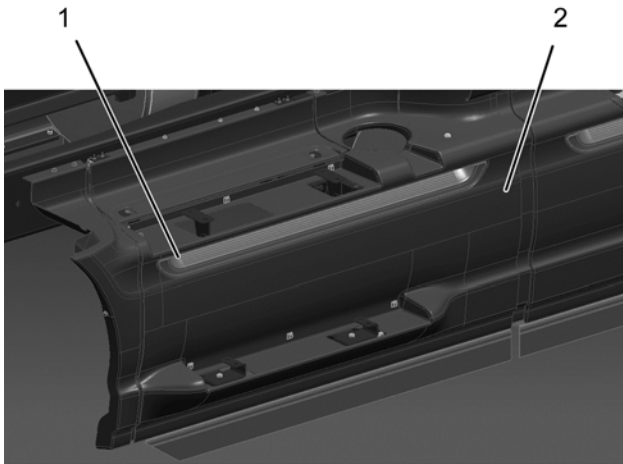

0000061988

Figure 22. Pocket Molding Panel.

1. Pocket molding panel
2. Front skirt panel assembly

38. Install pocket molding panel (Figure 22, Item 1) onto front skirt panel assembly (Figure 22, Item 2).

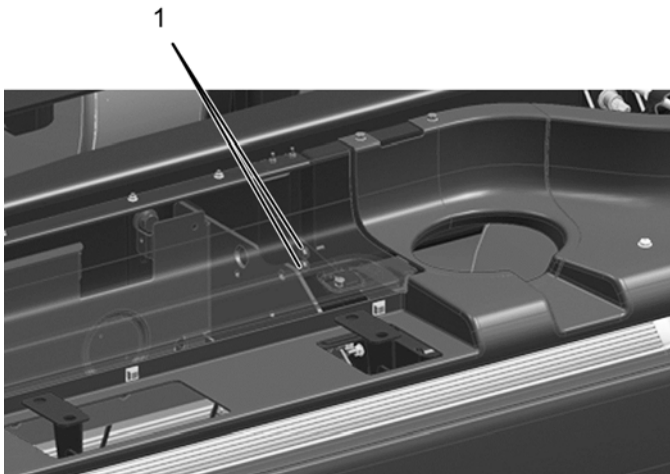

0000083982

Figure 23. Operator-Side Front Skirt Panel Bracket.

1. M8 bolt (2)

39. Install two bolts (Figure 23, Item 1) onto front skirt panel bracket.

40. Using torque wrench, tighten two bolts (Figure 23, Item 1) to 18 lb-ft (25 N·m).

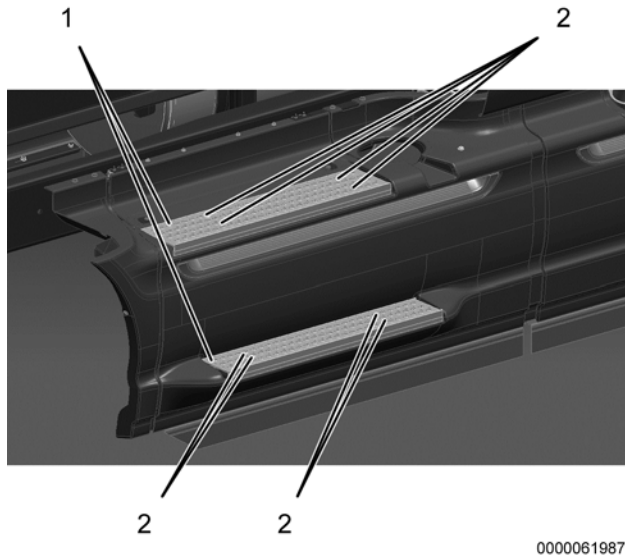

Figure 24. Front Skirt Panel Assembly.

1. Step (2)
2. M8 bolt (8)

41. Install upper and lower steps (Figure 24, Item 1) onto operator-side front skirt panel assembly.
42. Install eight bolts (Figure 24, Item 2). Using torque wrench, tighten eight bolts to 18 lb-ft (25 N·m).
43. Remove wheel chocks.

END OF SERVICE PROCEDURE

LABOR INFORMATION

Operation Number	Description	Time
A40-13517-01	Inspect and Shim Both Sides	2.6 hrs
A40-13517-02	Inspect and Shim Both Sides, Install Bracket One Side	3.3 hrs
A40-13517-03	Inspect and Shim Both Sides, Install Bracket Both Sides	4.0 hrs

CAMPAIGN IDENTIFICATION LABEL

Each vehicle corrected in accordance with this campaign must be marked with a CTS-1075 Campaign Identification Label.

Complete the label and attach on a clean surface next to the vehicle identification number (VIN) plate.

DO NOT REMOVE
INTERNATIONAL
Campaign No.
VIN
Eng.#
COMPLETED
Service Location Code #
DO NOT REMOVE

ADMINISTRATIVE / DEALER RESPONSIBILITIES

WARRANTY CLAIMS

Warranty claim expense is to be charged to Warranty. Claims are to be submitted in the normal manner, making reference to Safety Recall 13517.

It is important that the coding be completed properly to assist in processing the warranty claim. Complete instructions will be found in the Warranty Policy Manual, Section 7.1.8.

As with all claim submissions, items acquired locally must be submitted in the "Other Charges" tab. The cost of any bulk items (such as a bag of cable tie straps, roll of wire, a barrel of oil, or a tube of silicone) should be prorated for the cost of the individual pieces / amount used during each repair.

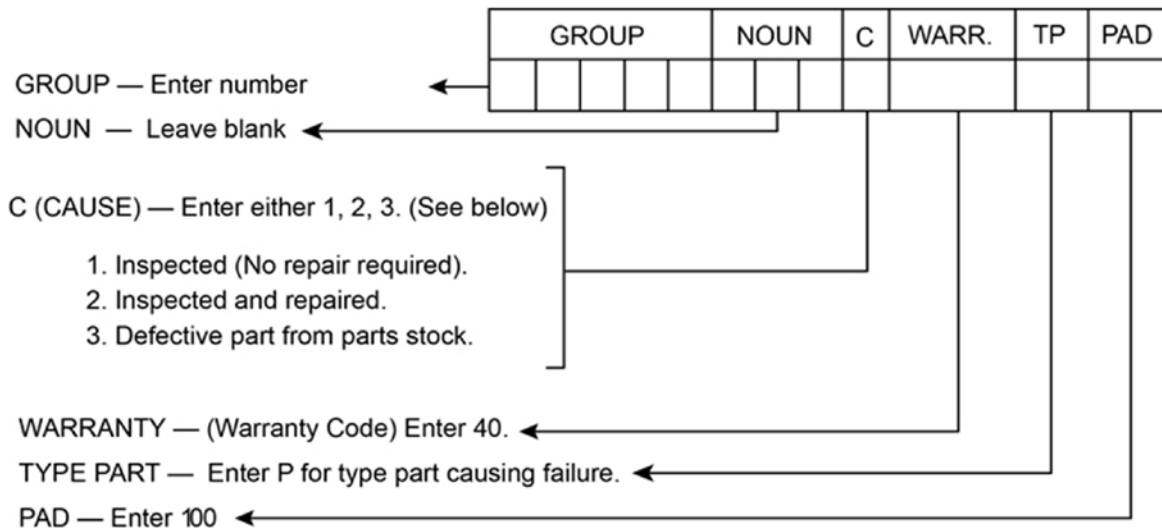

0000047910

UNITED STATES AND POSSESSIONS

The National Traffic and Motor Vehicle Safety Act, as amended, provides that each vehicle that is subject to a vehicle recall campaign must be adequately repaired within a reasonable time after the owner has tendered it for repair. A failure to adequately repair within 60 days after a tender of a vehicle is prima facie evidence of failure to repair within a reasonable time. If the condition is not adequately repaired within 60 days, the owner may be entitled to replacement with an identical or reasonable equivalent vehicle at no charge, or to a refund of the purchase price less a reasonable allowance for depreciation.

Dealers must correct all vehicles subject to this campaign at no charge to the owner, regardless of mileage, age of vehicle, or ownership, from this time forward.

Dealers should proceed immediately to make necessary correction to units in inventory. All inventory vehicles subject to this recall campaign must be corrected prior to sale, transfer or delivery. If vehicles have been sold or transferred and you are in receipt of Customer Notification Letters and Authorization for Recall Service cards for those vehicles, the transfer location or customer must be notified immediately from your dealer location.

Dealers must make every effort to promptly schedule an appointment with each owner to repair his or her vehicle as soon as possible. However, consistent with the customer notification, dealers are expected to complete the repairs on the mutually agreed upon service date.

Dealers involved in the recall process will be furnished a listing of owner names and addresses to enable them to follow up with owners and have the vehicles corrected. Use of this listing must be limited to this campaign because the list

may contain information obtained from state motor vehicle registration records, and the use of such motor vehicle registration data for purposes other than this campaign is a violation of law in several states.

CANADA

Dealers must correct all vehicles subject to this campaign at no charge to the owner, regardless of mileage, age of vehicle, or ownership, from this time forward.

Dealers should proceed immediately to make necessary correction to units in inventory. All inventory vehicles subject to this recall campaign must be corrected prior to sale, transfer or delivery. If vehicles have been sold or transferred and you are in receipt of Customer Notification Letters and Authorization for Recall Service cards for those vehicles, the transfer location or customer must be notified immediately from your dealer location.

Dealers must make every effort to promptly schedule an appointment with each owner to repair his or her vehicle as soon as possible. However, consistent with the customer notification, dealers are expected to complete the repairs on the mutually agreed upon service date.

Dealers involved in the recall process will be furnished a listing of owner names and addresses to enable them to follow up with owners and have the vehicles corrected. Use of this listing must be limited to this campaign because the list may contain information obtained from state motor vehicle registration records, and the use of such motor vehicle registration data for purposes other than this campaign is a violation of law in several states.

EXPORT

Export Distributors should proceed immediately to make necessary correction to units in inventory. All inventory vehicles subject to this recall campaign must be corrected prior to sale, transfer or delivery. If vehicles have been sold or transferred and you are in receipt of Customer Notification Letters and Authorization for Recall Service cards for those vehicles, the transfer location or customer must be notified immediately from your distributor location.

Export Distributors are to submit warranty claims in the usual manner, making reference to this recall number.

Export Distributors are expected to provide full cooperation and follow-up with respect to this important subject matter. If you have any questions or need further assistance, please contact the Regional Service Manager at your regional office.

NAVISTAR, INC.