



Countries:	CANADA, UNITED STATES, PUERTO RICO	Document ID:	IK1100005
Availability:	ISIS	Revision:	2
Major System:	CLUTCH	Created:	10/28/2010
Current Language:	English	Last Modified:	3/12/2014
Other Languages:	Français , Español ,	Author:	Matthew Boyer
Viewed:	2501		

[Less Info](#)

Hide Details

Coding Information

Copy Link	Copy Relative Link	Bookmark	Add to Favorites	Print	Provide Feedback	Helpful	Not Helpful
		 View My Bookmarks				 262	 578

Title: Eaton Clutch Information

Applies To: Transtar Workstar Prostar Lonestar

DESCRIPTION

Information For Troubleshooting Eaton Clutch Complaints

SYMPTOMS

- No clutch brake when pedal is depressed.
- Noise when pedal is depressed to floor.
- Clutch fork hits pressure plate when pedal is depressed.
- Stiff or hard to depress pedal

TROUBLESHOOTING

1. Inspect the fork, lever, and left cross shaft and record part numbers.
1. Inspect the pressure plate for signs of damage from the fork hitting it.
2. Check linkage for worn or seized hyme joint.

RESOLUTION

- Verify the part numbers you recorded with your parts department to insure you have the correct parts installed on the unit. **[It is possible to install a standard fork in a roller clutch resulting in poor clutch brake operation or possible fork hitting pressure plate when the pedal is fully depressed. See Figure 1]**
- A incorrect lever or cross shaft can also cause no clutch brake issues or interference issues.
- Install the correct part if you determine that the incorrect one was installed.
- Open a Parts Inquiry case file if you have questions determining the correct parts.
- Make sure cross shafts and linkage is lubed properly.
- Replaced seized hyme joints. **[They will break and leave the driver without clutch operation if the issue gets to severe]**

OTHER RESOURCES

Figure 1

The Solo® XL release bearing housing has also been redesigned to fit the 97-509-10-1X Roller Yoke.

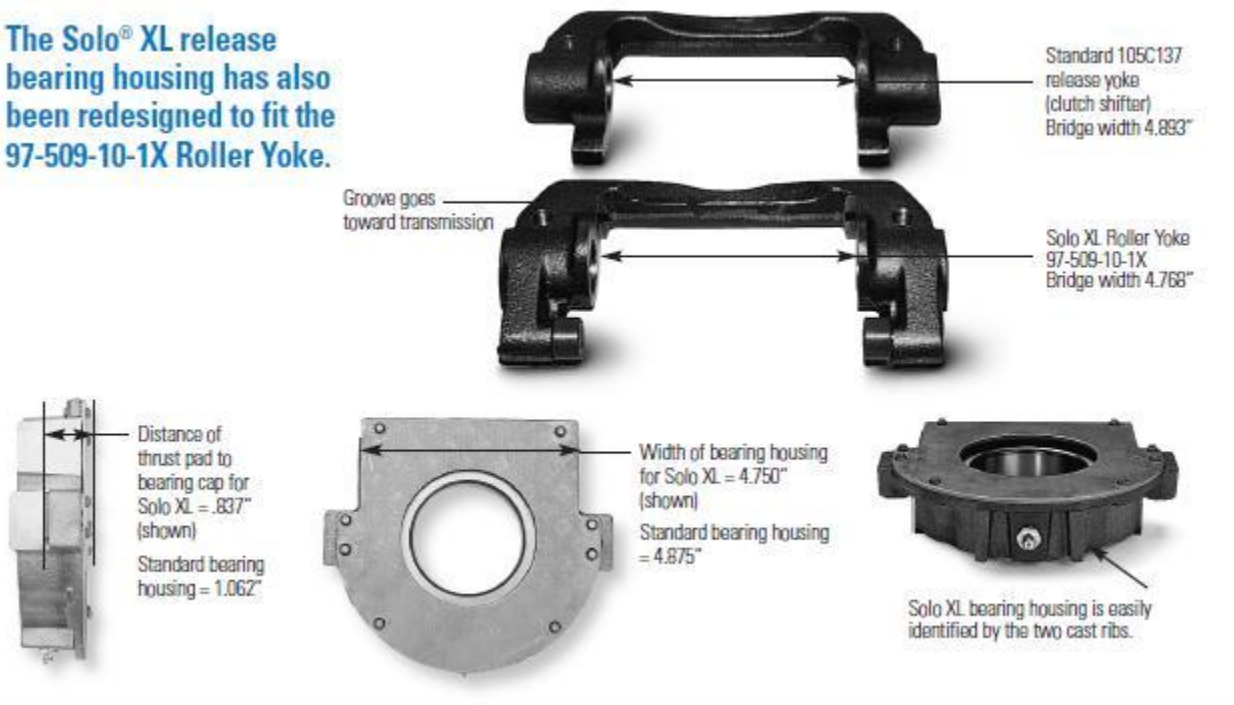

http://www.roadranger.com/Roadranger/servicesalesliterature/LiteratureCenterResults/index.htm?&pt=OW_GL_RR&target=1162919212477

Hide Details

Feedback Information

Viewed: 2500
Helpful: 262
Not Helpful: 578

Staff ID	Client ID	Comments	Created Date
	U00MSE1	You received the following feedback From: u00mse1 - Mark Ehlers Email Address: SMTP: {mark.ehlers@navistar.com}mark.ehlers@navistar.com Job Classification: AD001, Administration Dealer: Field Personnel Feedback: link at bottom of article is not working	3/14/2014 2:02:13 PM

Copyright © 2014 Navistar, Inc.