



# Service Bulletin

File in Section: 03 - Suspension

Bulletin No.: 14-03-10-001A

Date: October, 2014

## INFORMATION

**Subject:** Tire Hop / Tire Chatter During Tight Turns at Parking Lot Speeds

**Models:** 2014-2015 Chevrolet Corvette, Corvette Z51  
2015 Chevrolet Corvette Z06

This bulletin has been revised to add the 2015 Model Year.  
Please discard Corporate Bulletin Number 14-03-10-001.

### Information on Tire Hop

Customers may comment about a front end or suspension noise when backing or driving forward at low speed in a very tight left or right turn (such as in a parking lot or driveway). The condition is made worse in cooler temperatures. This has been referred to as tire hop, crow hop, tire pop and has been confused with rear differential chatter. There have been several bulletins, videos and training pieces published in attempt to describe the noise and explain that the condition is considered normal. (For dealers in the U.S., see January 14, Emerging Issues "Corvette Tire Hop Story"). This concern is not new for the Corvette, it has been raised by customers of older Corvettes and other vehicles with a wide stance and wide tires.

### What Induces Tire Hop?

The 2014 and 2015 Corvette Stingray may have more noticeable tire chatter than previous years due to several factors explained below:

- Imperfect Ackermann Steering Geometry and Sticky Tires** – Tire chatter occurs when the car is turning at low speeds and tight steering angles because the left and right front tires do not follow the same arcs. The Corvette's sticky tires then build up force as they turn on the different arcs until eventually one or both tires slip. Ackermann steering geometry is shown in the diagram below. On a car with perfect Ackermann, the inside tire angle ( $S_i$ ) and outside tire angle ( $S_o$ ) follow the same arc. On a Corvette Stingray, at large steering angles, they do not follow the same arc.

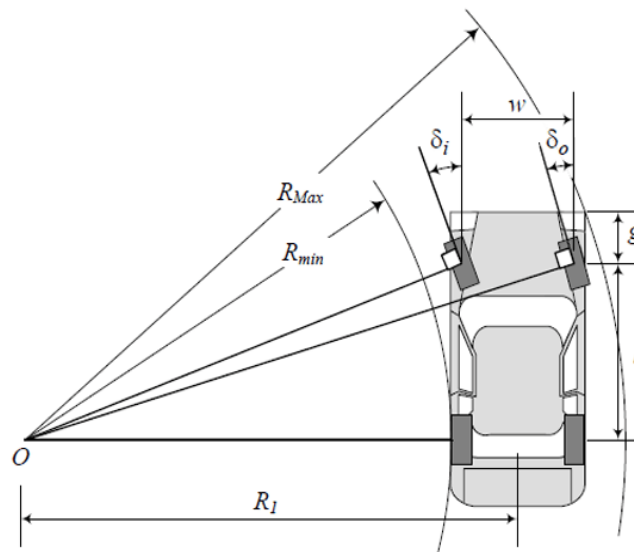

## **Why Do The Tires Not Follow the Same Arc?**

- 1.1. It allows the car to be built to package larger brakes, reasonable wheel offsets, and a wider stance. These allow superior handling and performance and makes room for the large V-8 engine.
- 1.2. The Stingray has a tighter turning radius than the previous generation Corvette by two feet. This tighter turning radius makes the tire angles more extreme. While this may increase tire hop it affords the driver greater low speed maneuverability.
- 1.3. Tire design is a key factor for tire chatter. The Corvette Stingray tires are optimized for precise steering and high grip in warm temperatures. The Michelin winter tire (available through service parts) is a more applicable solution for cold weather driving, and chatter is much improved with this tire.
2. **What Can be Done to Improve the Condition?** – Changing to a less aggressive tire is not recommended as it will reduce the effectiveness of the Corvette Stingray and its handling characteristics. The suspension, handling and performance of the Corvette Stingray is a complete design package. To achieve the performance customers expect and demand, a single component cannot be changed without sacrificing the other components. There is no adverse wear to the tires when tire hop is encountered and it does not affect the suspension - the car is working as designed. Additionally, GM has not tested or validated other tires or wheels and cannot predict how the car will handle, or how the ABS and Active Handling will perform with other equipment.
3. **Will Changing Tires Make a Difference?** – As stated above the tires are in integral component of the Stingray's ride, handling and performance. The recommended Michelin Winter tires will reduce the noise but it is not designed for warm weather handling.
4. **Is There an All-Season Tire That Can be Used?** – There are several tire manufacturers that indicate their "All-Season" tires will fit the Stingray however, GM has not tested or validated any of these tires.

While a customer may find the noise troubling and/or annoying, the car is operating as designed. Tire hop was more common on the previous generation Corvette Z06, ZR1 and Grand Sport models. It is more noticeable on the Corvette Stingray because much of the performance from those previous up-level models has been designed into the standard Stingray. Aside from the exceptional design and appearance, the outstanding performance, and handling is one of the reasons customers choose to purchase the Corvette Stingray. To achieve this type of performance, some tire hop is inevitable.