



Service Bulletin

PRELIMINARY INFORMATION

Subject: Unable To Connect High Voltage Cable To Replacement Accessory DC Power Control Module (APM)

Models: 2011-2013 Chevrolet Volt

The following diagnosis might be helpful if the vehicle exhibits the symptom(s) described in this PI.

Condition/Concern

Certain 2011-2013 Chevrolet Volts were equipped with a first design APM which has a 24 inch orange pigtail attached to the module and there is no high voltage connection right at the module itself (See Photo Below)

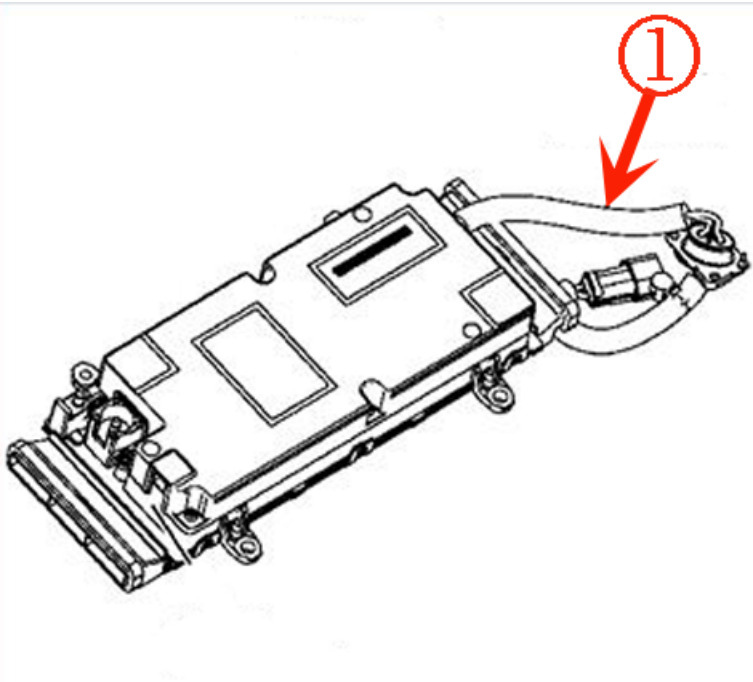

When replacing the APM with a new service part APM, you will notice that the new part has no pigtail and the high voltage connection is right at the module itself (See Photo Below)

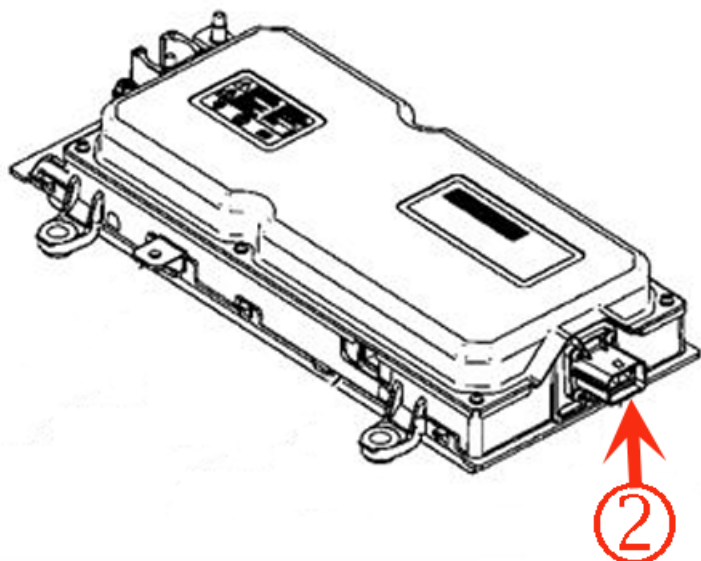

Recommendation/Instructions

If your vehicle has a first design module and you are replacing the APM , an additional jumper harness (GM Part Number 24268507) will need to be installed. An instruction sheet will be provided with the jumper harness kit on how to install the new design module. If the jumper harness instructions were not included with the new part, please contact the Technical Assistance Center for a copy of the instruction sheet.

Parts Information

Model year	Part Number	Description	Qty
2011-2013 Chevy Volt	24268507	Pigtail Jumper Harness (needed with first design APM)	1

Warranty Information

For wiring repairs covered under warranty, please refer to latest version of bulletin 10-00-89-005 for warranty information on wire/connector repairs.

Please follow this diagnostic or repair process thoroughly and complete each step. If the condition exhibited is resolved without completing every step, the remaining steps do not need to be performed.

GM bulletins are intended for use by professional technicians, NOT a "do-it-yourselfer". They are written to inform these technicians of conditions that may occur on some vehicles, or to provide information that could assist in the proper service of a vehicle. Properly trained technicians have the equipment, tools, safety instructions, and know-how to do a job properly and safely. If a condition is described, DO NOT assume that the bulletin applies to your vehicle, or that your vehicle will have that condition. See your GM dealer for information on whether your vehicle may benefit from the information.



WE SUPPORT VOLUNTARY TECHNICIAN CERTIFICATION