

PREVOST

Instruction Sheet

IS-14130

Retrofit kit for obsolete small AC condensers (950018 & 950335)

MATERIAL

Kit #IS14130 includes the following parts:

Part No.	Description	Qty
052382	Condenser Support	2
053697	Rear Bracket	1
053698	Front Bracket	1
950958	Condenser, Heavy Duty	1
502622	M6-1.0 x 20 Hex Screw SS	8
502565	Nut, Hex M6-1.0 SS	8
500411	Washer, Flat SS	8
502570	Lock Washer SS	8
IS-14130	Instruction Sheet (EN)	1
FI-14130	Instruction Sheet (FR)	1

NOTE

Material can be obtained through regular channels.

PROCEDURE



DANGER

Park vehicle safely, apply parking brake, stop engine and set battery master switch(es) to the OFF position prior to working on the vehicle.



DANGER

One of the most important precautions when handling refrigerant consists in protecting the eyes. Any liquid refrigerant which may accidentally escape is approximately -40°F (-40°C). If refrigerant comes in contact with the eyes, serious injury could result. Always wear goggles to protect the eyes when opening refrigerant connections.

1. Purge the vehicle the A/C system (Refer to section 22 "Heating and Air Conditioning" of the vehicle Maintenance Manual).



CAUTION

The evacuation of the system must be made by authorized and qualified personnel only. Refer to local laws for R-134a recuperation.

2. Disconnect the refrigerant lines and remove the condenser and support assembly from the vehicle.
3. Install both 052382 condenser support on the radiator frame.
4. Install front (053697) and rear (053698) bracket on the condenser support.

NOTE: Refer to bracket identification (below) for proper installation.



5. Slide the new condenser between the brackets and the radiator and secure in place using appropriate hardware with the condenser connections facing the *front* of the vehicle.

NOTE: The two condenser connections are of slightly different diameter, the upper part of the condenser is the part with the larger diameter connection (see below).

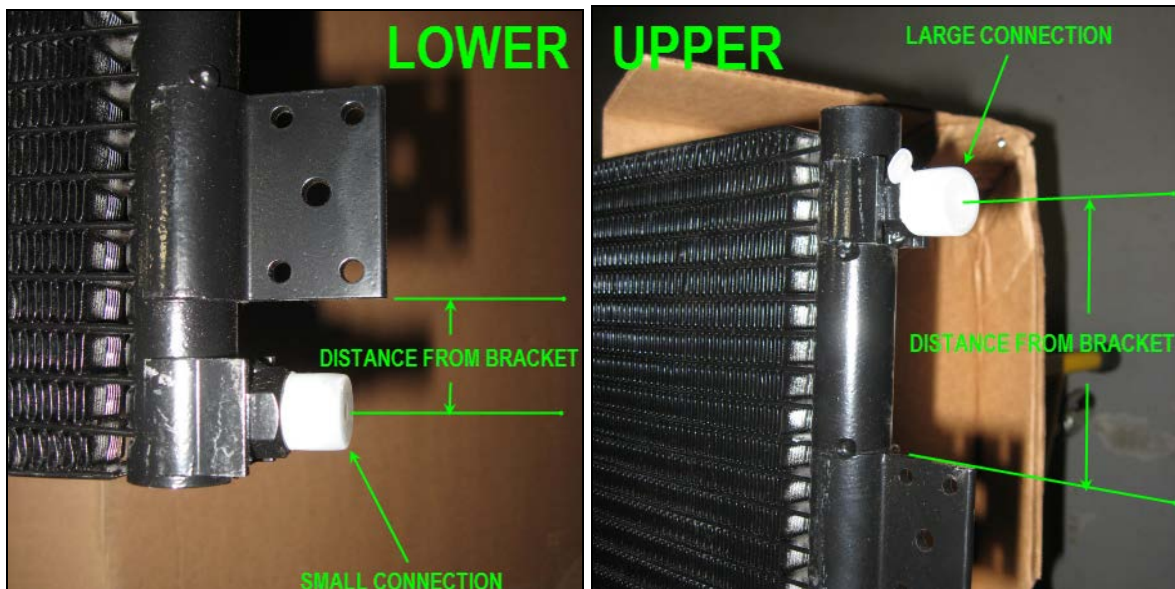

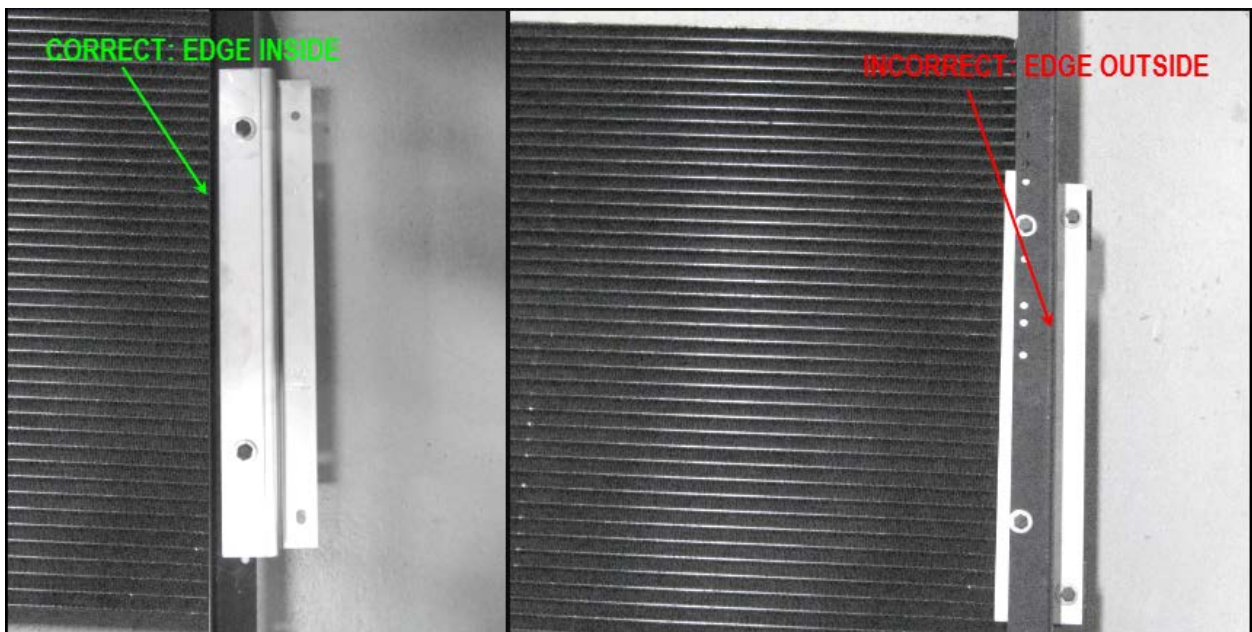
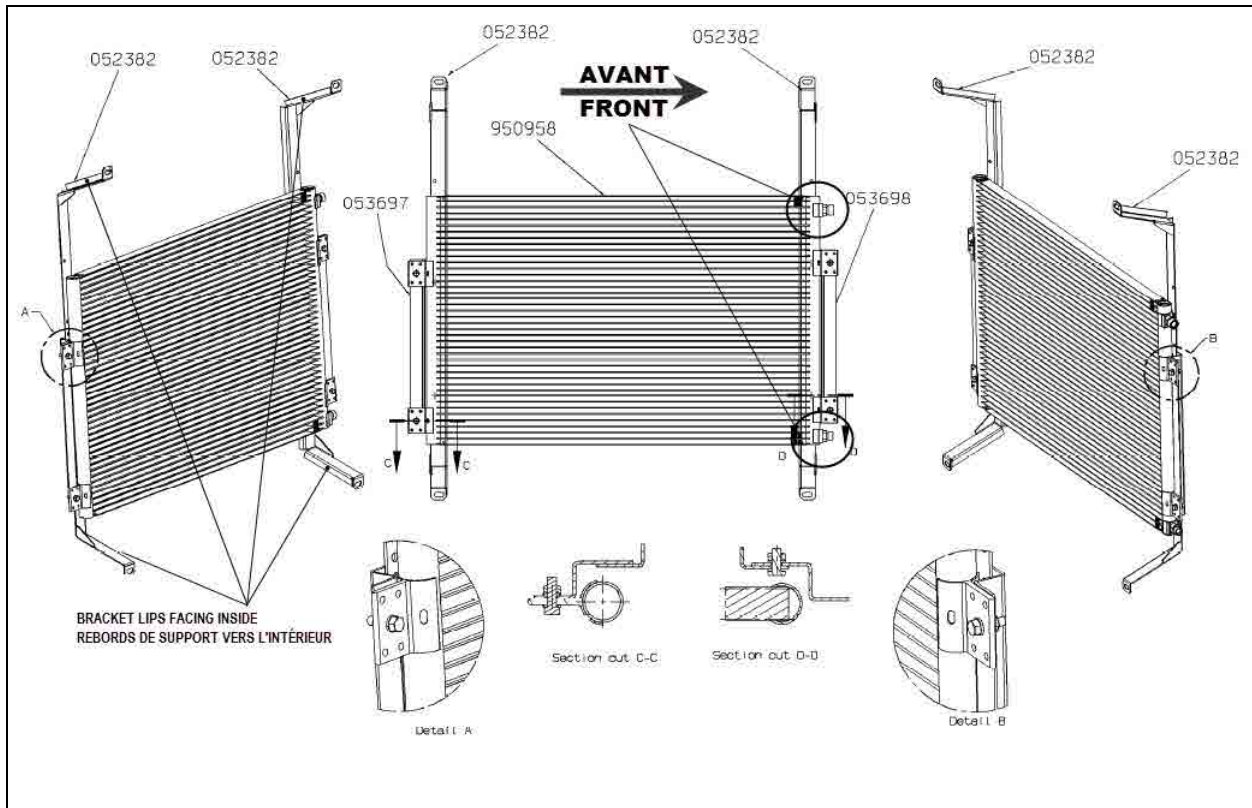

6. Connect the condenser refrigerant lines to the new condenser.

NOTE: Depending on the vehicle configuration, it may be necessary to lengthen the lower line to be able to connect it to the new condenser.

7. Fill the A/C system with R134a refrigerant and check proper operation of the system.

PARTS / WASTE DISPOSAL

Discard waste according to applicable environmental regulations (Municipal/State[Prov.]/ Federal)