

| Date | Expiration | Release | Page |
|---------|------------|---------|-------|
| 09.2014 | 09.2016 | 1 | 1(26) |

Release 1: This document supersedes previous revisions.
 Nov 10, 2014 Added desired bulb position and MUX software verification.

BITZER COMPRESSOR REMOTE PRESSURE SENSORS AND SWITCH

Prevost vehicles

DESCRIPTION

This bulletin is performed on a fix as fail basis. On the vehicles affected by this bulletin, update to the latest configuration of wiring and sensors for the Bitzer compressor.

APPLICATION

| NOTICE TO SERVICE CENTERS Verify vehicle eligibility by checking warranty bulletin status with SAP or via ONLINE WARRANTY SYSTEM available on Service / Warranty tab of Prevost website. | |
|--|--|
| Model | VIN |
| H3-41, H3-45 coaches Model Year : 2013 - 2015 |  Single vehicle 2PCH33494 DC712272 and from 2PCH33499 DC712364 up to 2PCH33492 FC712760 , incl. |
| H3-45 VIP motorhomes Model Year : 2013 - 2014 | From 2PCVS3499 DC712399 up to 2PCVS3493 FC712742 , incl. |
| X3-45 coaches Model Year : 2013 - 2014 | Single vehicles 2PCG33491 DC735388 , 2PCG33492 DC735433 and from 2PCG33497 EC735459 up to 2PCG33496 FC735776 , incl. |
| X3-45 Commuter Model Year : 2014 | Single vehicles 2PCG33491 EC735571 , 2PCG33495 EC735590 , 2PCG33498 EC735602 |
| XLII-45 Entertainer Model Year : 2013 | Single vehicles 2PCYS3492 DC735374 , 2PCY33491 DC735461 , 2PCYS3490 DC735468 , 2PCYS3498 DC735489 |
| X3-45 VIP motorhomes Model Year : 2014 | Single vehicles 2PCBS3499 EC735539 , 2PCBS3499 EC735587 , |
| X3-45 VIP commercial use Model Year : 2014 | From 2PCCS3497 EC735494 up to 2PCCS3498 EC735778 , incl. |
| This bulletin does not necessarily apply to all the above-mentioned vehicles, some vehicles may have been modified before delivery. The owners of the vehicles affected by this bulletin will be advised by a letter indicating the Vehicle Identification Number (VIN) of each vehicle concerned. | |

| Date | Expiration | Release | Page |
|---------|------------|---------|-------|
| 09.2014 | 09.2016 | 1 | 2(26) |

DESCRIPTION

On the vehicles affected by this bulletin, perform the following verifications and modifications on the A/C system.

Part of this bulletin must be carried out by qualified A/C technicians.

Order one of these two kits, depending on vehicle serial number and bulletin history:

WB14-06-1 Order this kit. Applies to all vehicles.

Kit includes parts required for the installation of remote pressure sensors and switch.

WB14-06 Order only for vehicles that have not received bulletin WB14-06 with serial number before E-5697(X series) / E-2651 (H series), included.

Kit includes all components required for an updated wiring.

STEP 1: Tighten the unloader cap on the A/C compressor. Inspect and replace unloader if lost.

STEP 2: System vacuum, wiring update, remote pressure transducer and switch installation.

STEP 3: Seal the evaporator compartment ventilation discharge duct.

STEP 4: Check Evaporator expansion valve bulb position and MUX software version.

STEP 5: Dynamic A/C system test to confirm all functions operate correctly.

NOTE







Any leak repair or standard A/C system maintenance is outside the scope of this bulletin and *should not* be charged to the bulletin.

Even if this type of work may fall under vehicle warranty, parts and labor should be placed under another operation.

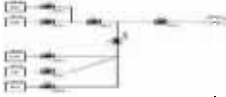
MATERIAL

For vehicles that have not received bulletin WB14-06 and serial number before E-5697 (X series) / E-2651 (H series), included.

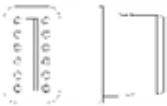

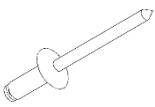



Kit **WB14-06** which includes the following parts:

| Part No. | Description | Qty |
|--|---|-----|
| 067349  | Cable support | 1 |
| 069206  | Compressor Harness | 1 |
| 509815  | Christmas tree cable tie base | 1 |
| 504013  | Cable tie base | 3 |
| 563227  | Deutsch Socket housing, DT series, 12C, <i>black</i> | 1 |
| 562887  | Deutsch Socket terminal | 10 |
| 563228  | Deutsch Secondary lock, DT series, 12C | 1 |
| 561996  | Deutsch terminal cavity seal plug | 2 |
| 504379  | Dome pop rivet 3/16 dia x 1/4, <u>Stainless Steel</u> | 5 |

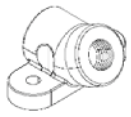
MATERIAL

For All Vehicles

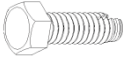
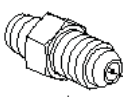
Kit **WB14-06-1** includes the following parts:

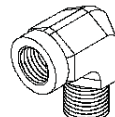
| Part No. | Description | Qty |
|--|---|-----|
| 504751  | Swivel double cable tie base | 5 |
| 640643  | Elbow 45° 1/4 NPT F X 1/4 NPT F w/ mounting flange | 2 |
| 457743 | Hose #4 400mm SAE 45°F | 2 |
| 501894  | Tee 1/4 NPT F-M-F | 1 |
| 501026  | Union Fitting-Hose- compressor side SAE 45° / #4FL-Mx1/8NPT-M | 2 |
| 501027  | Union Fitting Hose transducer side SAE 45° FITTING / #4FL-Mx1/4NPT-M | 2 |
| 501303  | Bouchon 1/8 NPT | 1 |
| 502848  | Thread cutting screw 1/4-20 x 3/4 | 4 |
| 950249  | Union Fitting 1/4 NPT - SAE45° Schrader Valve | 3 |
| 501329  | 45deg Elbow fitting 1/4 NPT | 2 |
| 501332  | 90 deg elbow fitting 1/4 NPT | 1 |

Parts to purchase locally, required for the bulletin:

Date Expiration Release Page
 09.2014 09.2016 1 5(26)

| Part No. | Description | Qty |
|----------|--|-----|
| 680532 | Sika 221, 310ml Cartridge | A/R |
| 680098 | Loctite 567 thread sealant, 250ml | 1 |
| 564099 | Electrical harness tape, cloth, black, 150°C | 1 |
| 069099 | Wiring support | 1 |
| - | High temperature cable tie assortment | A/R |
| - | "Torque seal" paint tube | A/R |

Other parts that may be required depending on system condition:

| Part No. | Description | Qty |
|----------|----------------------------------|-----|
| 680091 | Insulating tape 1/8" x 2" | A/R |
| 561567 | Pin terminal 18-16, Weather pack | A/R |
| 950506 | Gasket, Discharge Valve | 1 |
| 950563 | Cap, Metal Coil Fixing "Bitzer" | 1 |
| 950513 | Kit, Unloader Head "Bitzer" | 1 |
| 950498 | Pressure switch assy "Bitzer" | 1 |
| 950504 | Pressure transducer "Bitzer" | 2 |

TOOLS

| Part No. | Description | Qty |
|---|--------------------------------------|-----|
| 7775028  | Cap adaptor tool, 1/4 Drive | 1 |
| -  | Torque wrench 10-50 Lbf-in range | 1 |
| -  | Pop rivet gun | 1 |
| -  | Refrigerant Recovery & Recharge unit | 1 |
|  | Manifold gage set | 1 |

| Date | Expiration | Release | Page |
|---------|------------|---------|-------|
| 09.2014 | 09.2016 | 1 | 6(26) |

NOTE

Material can be obtained through regular channels.



CAUTION

State / Province / Federal regulations and laws take precedence over guidelines and instructions supplied in this document. Perform work according to best practices with safety in mind.

PROCEDURE



DANGER

Park vehicle safely, apply parking brake, stop engine and set battery master switch(es) to the OFF position prior to working on the vehicle.

STEP 1:

Please read carefully Bitzer Technical bulletin TB-0049, at the end of this document.

(Prevost tool is slightly different from images)

Order the following parts as required:

950563 Cap, Metal Coil Fixing

Using tool 7775028, adjust torque wrench to 26 lbf-in (3N-m) and tighten the unloader cap following instructions in Bitzer bulletin.

Once this is done, apply a drop of "torque seal". (Fig. 1)



Figure 1

If the unloader cap is missing:

- Check Multiplex for presence of unloader fault code.
- If required, replace unloader assembly, refer to step 2.1.

Order **950513** Kit, Unloader Head



Figure 2

STEP 2:

Refrigerant must be removed from the system before replacing a damaged unloader and installing the new wiring management bracket.



WARNING

One of the most important precautions when handling refrigerant consists in protecting the eyes. Any liquid refrigerant which may accidentally escape is approximately -40°F (-40°C). If refrigerant comes in contact with the eyes, serious injury could result. Always wear goggles to protect the eyes when opening refrigerant connections.

2.1. System vacuum



Figure 3

This step should be carried out by qualified personnel authorized to work on A/C systems. Use safe work practices when working with refrigerant. Wear long sleeves, gloves and goggles.

Perform work according to best practices and applicable laws and regulations.

Before changing the cable harness and cable guide, or relocating pressure transducers, perform a vacuum of the refrigerant gas to remove as much gas as possible from the system and isolate the compressor from the rest of the system.

- Connect the refrigerant recovery unit (Fig. 2) and perform refrigerant vacuum.
- Once the system is refrigerant free, close the suction line and discharge valves on the compressor;
- Unscrew the discharge valve cover bolts.
- Inspect and replace the unloader if damaged or defective or if the cap was missing (Step 1).
Order 950513 Kit, Unloader Head

2.1.1. System vacuum for vehicles having the updated version of the wiring and bracket.

Perform this step if your vehicle has the latest version of the cable management bracket (Fig. 4).

Only isolate the compressor and remove refrigerant gas in this section.



WARNING

Risk of refrigerant contamination!

Do not perform pressure tests with nitrogen when the compressor is isolated from the system

After all work on compressor is completed, perform a vacuum and test for leaks and re-claim refrigerant. (Step 2.14)

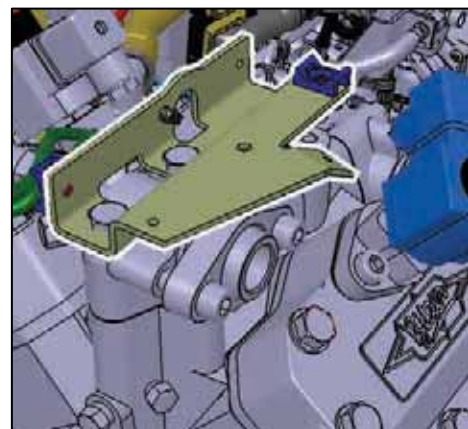

Figure 4

| Date | Expiration | Release | Page |
|---------|------------|---------|-------|
| 09.2014 | 09.2016 | 1 | 8(26) |

2.2. *C228 connector

*Skip to next step if this connector is already on the vehicle.

Look on cable management bracket located on the right hand side of the engine. (Fig 5)

On the compressor, disconnect and remove all electrical wiring coming from engine harness to the compressor.

Ensure cleanliness for the following steps.

Make sure the circuit number is visible for identification.

On vehicle side, take the main branch leading to the old compressor pigtail. Remove loom, tape above the pigtail junction. (Fig. 6)

Cut two inches (2in.) above junction and strip the wires to install ten (10) Deutsch terminals. See table.

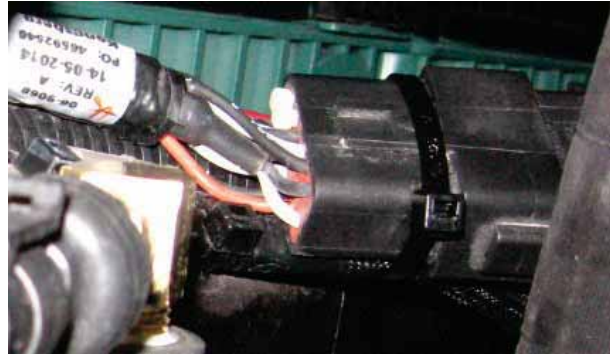

Figure 5 Connector C228



Figure 6 Vehicle harness stripping

On Deutsch connector #563227 (C228), assemble the stripped wires with terminals and insert them in the indicated positions per wire circuit (see table below).

| All models | | |
|-----------------|---------|----------|
| Cavity | Circuit | Terminal |
| 1 | 77 | 562887 |
| 2 | 88 | 562887 |
| 3 | 79 | 562887 |
| 4 ¹ | 13 | 562887 |
| 5 | 77BA | 562887 |
| 6 | 31 | 562887 |
| 7 ² | 0RA2 | 562887 |
| 8 ² | 0RA2 | 562887 |
| 9 | 88 | 562887 |
| 10 ¹ | 13 | 562887 |
| 11 | - | 561996 |
| 12 | - | 561996 |

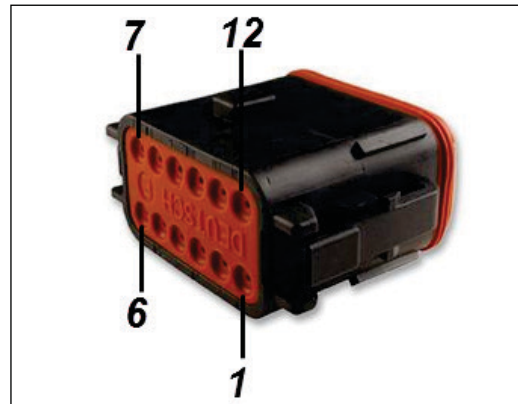

Figure 7 Connector cavity reference

¹ Positions 4 & 10: any wire printed "30"

² Positions 7 & 8: any wire printed "0RA2"

2.3. Preparation and removal of components

Remove SE23 and SE24.

At location where SE24 was installed on compressor, remove Schrader spring valve inserted in fitting.

Install plug #501303 in port where SE23 was installed. Seal with #680869. (Fig. 8)

Remove SE29

At location where was installed SE29, remove Schrader spring valve inserted in fitting. (Fig. 8)

Remove the grey elbow connector on the capacity control solenoid (Unloader). The new harness #069206 includes this connector.

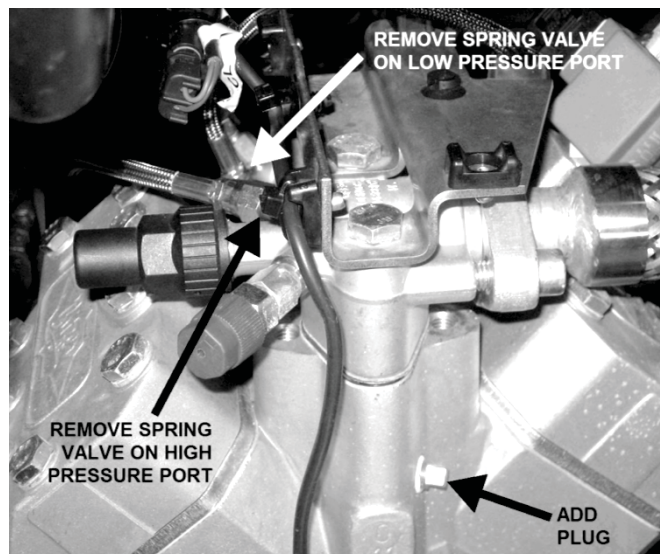

Figure 8

2.4. 640643 flanged elbow fitting assembly

Assemble one each of these two assemblies, adding the transducers and switch at indicated locations. (Fig. 9 & 10)

Apply sealant.

Rotate tee and elbow at about 15degrees from 640643 mounting flange. (Fig. 11)

Install hoses 457743 on union fittings 501027 (No sealant required on SAE 45 connections).

Install Instruments SE23, SE24 and SE29 as shown.

Test airtightness of fitting assemblies and hoses with nitrogen gas. Use soapy water to reveal any leak.

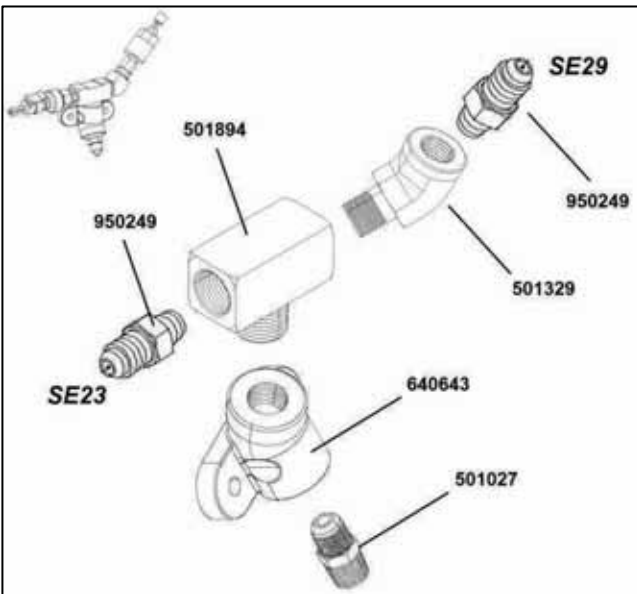

Figure 9 : SE23 & SE29 Assembly

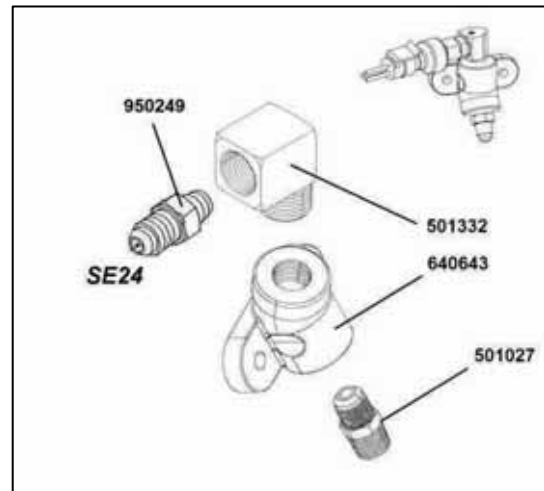

Figure 10 SE24 Assembly



Figure 11 Fitting Assembly Rotation.

| Date | Expiration | Release | Page |
|---------|------------|---------|--------|
| 09.2014 | 09.2016 | 1 | 11(26) |

2.5. *Wiring inspection*

Inspect all remaining electrical connections and wires.

- High pressure sensor #950504
- Low pressure sensor #950504
- High pressure switch #950498
- Clutch wiring

Pull on wires to make sure they are well crimped in the terminal and well seated in the connector. Repair with new "Weather Pack" terminal #561567 where required.

On the other end, make sure they are well attached to the component

Inspect wires for signs of premature wear, thermal degradation, dents, chaffing. If any of the above conditions are found, replace the component.

2.6. **Cable support pre-assembly.*

***Skip this step if your vehicle already has this bracket on the compressor.**

Place cable tie bases #504013 with Stainless Steel dome pop rivets #504379. (Fig. 12)

Add one #509815 cable tie base with christmas tree in the hole located in the center of the cable support.

Important:

Do not assemble with aluminum rivets.

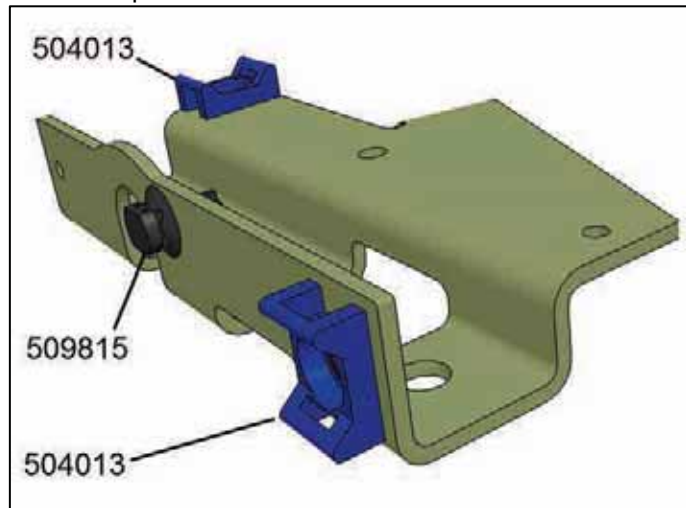

Figure 12

| Date | Expiration | Release | Page |
|---------|------------|---------|--------|
| 09.2014 | 09.2016 | 1 | 12(26) |

2.7. **Cable support installation*

***Skip this step if your vehicle already has this bracket on the compressor.**

Install new support #067349 as shown.
Torque discharge valve cover bolts to:

38-42 lbf -ft.

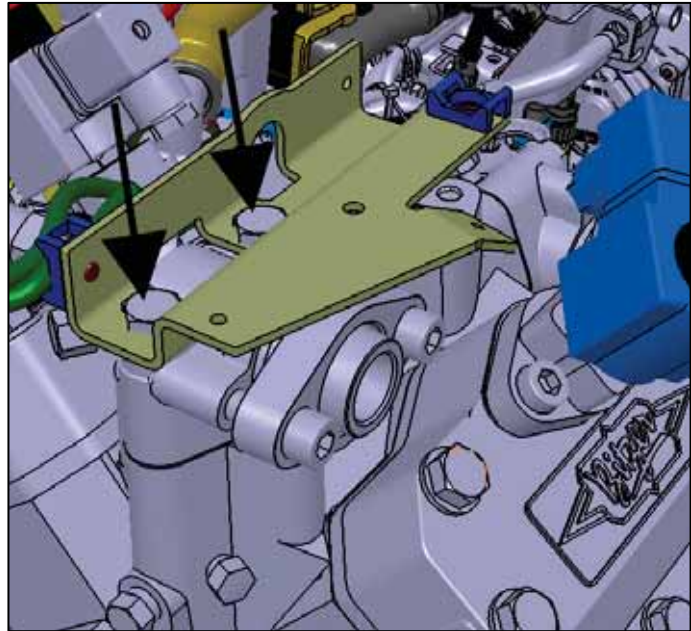

Figure 13

2.8. *H series vehicle tip*

Create some working space by undoing the grey air intake tube and attaching it higher (Fig 14)

Block both openings with a masking tape or a clean lintless cloth.



Figure 14

- 2.9. On the right side of the engine, locate the cable management bracket. Remove cable tie anchor points. (Fig 15) Some vehicles may not have these anchors. See next step.



Figure 15

Using cable tie anchor holes as reference, drill two new diameter 7/32" holes towards the center, 41mm apart.

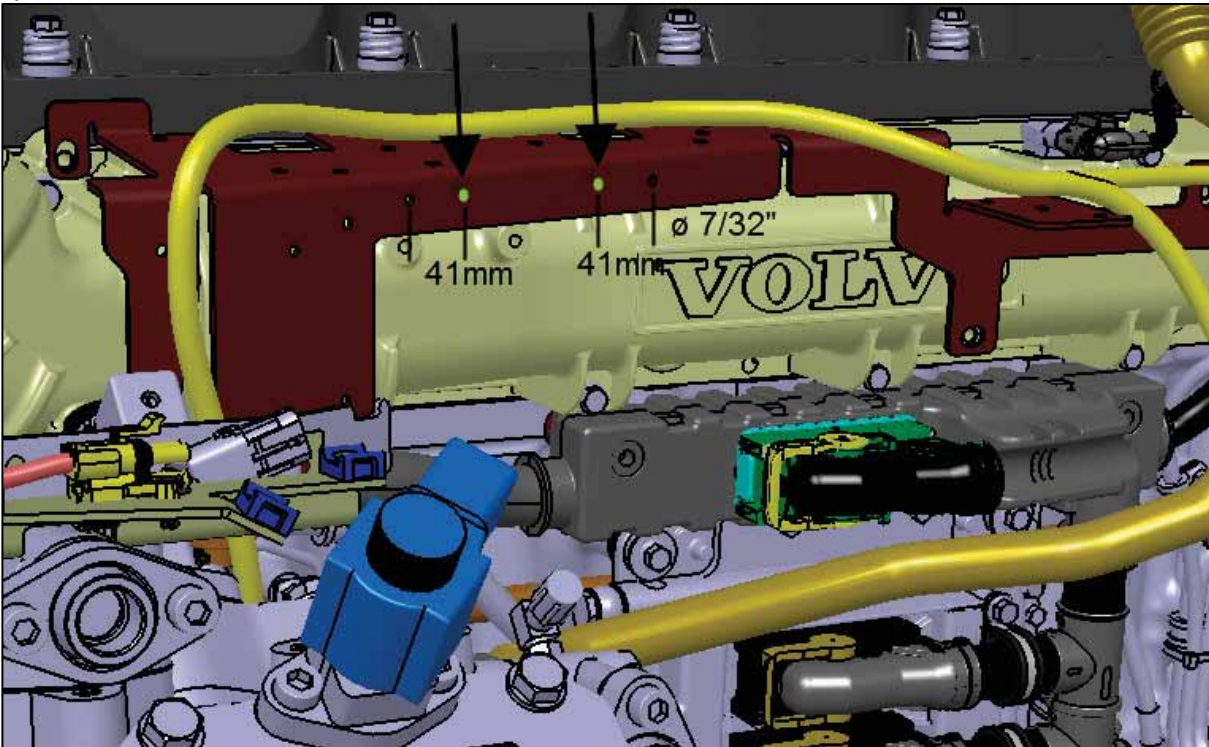

Use flanged elbow **640643** as a drilling template to get 41mm dimension.

- 2.10. On certain vehicles the cable support will not have reference holes.
Four (4) new holes will need to be drilled. Use dimensions provided below. (Fig. 16)

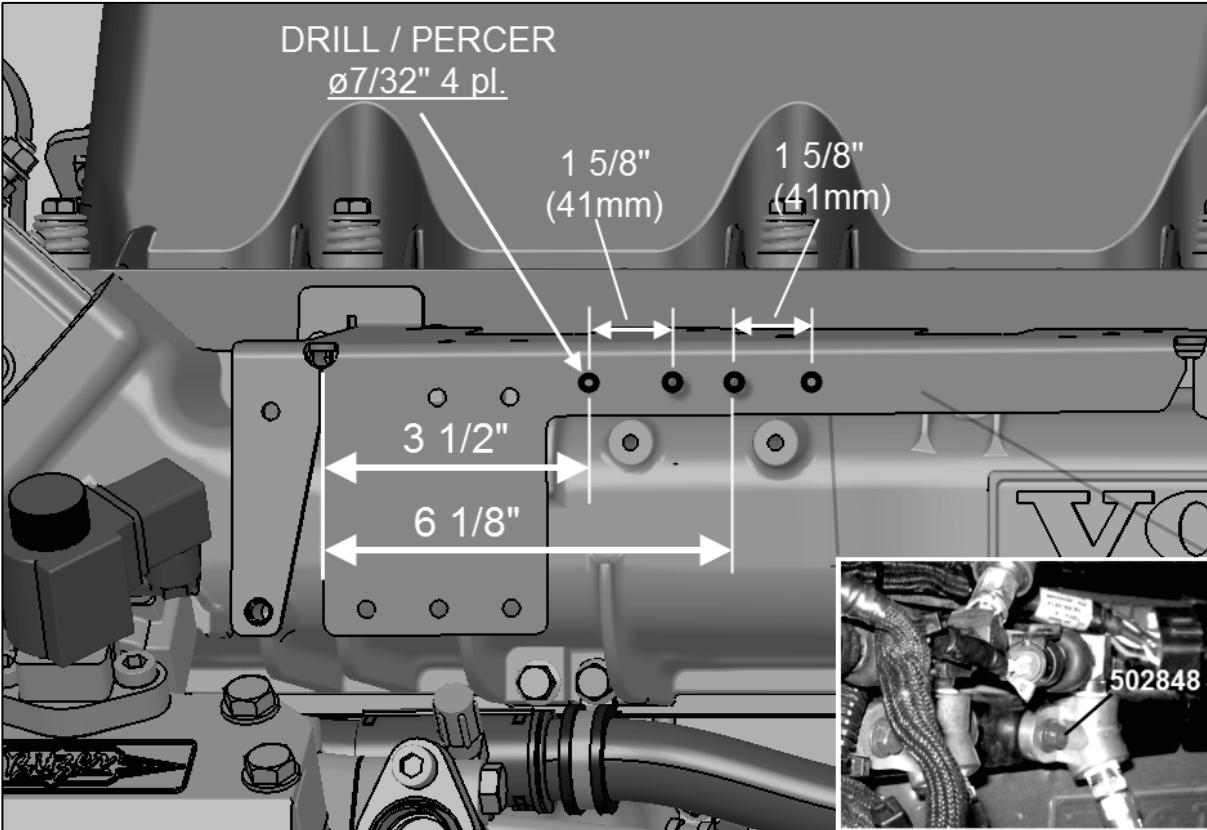

Figure 16: Drilling on the cable support

Secure fitting assemblies with thread cutting screws 502848 (Fig 16)

| Date | Expiration | Release | Page |
|---------|------------|---------|--------|
| 09.2014 | 09.2016 | 1 | 15(26) |

2.11. *New harness installation*

Take special care to route the harness according to the following figures. Refer to best practices at the end of this document. Prefer larger, heat resistant cable ties over small cable ties to limit the “pinch effect”.

- 2.11.1. Install new harness **069206** by connecting **L199** to the unloader.
- 2.11.2. Secure the cable on the cable tie mounts. **Until 069099 is available as a service part, route to avoid sharp edges.** (Fig. 17, 18).
- 2.11.3. Connect **So9** to the clutch connector.
- 2.11.4. Install one swivel cable tie base **504751** on the flexible section of the oil fill tube. (Fig. 18). Secure clutch connector in an orientation that allows easy disconnection. Tie excess length of cable by making loops. (Fig. 18)

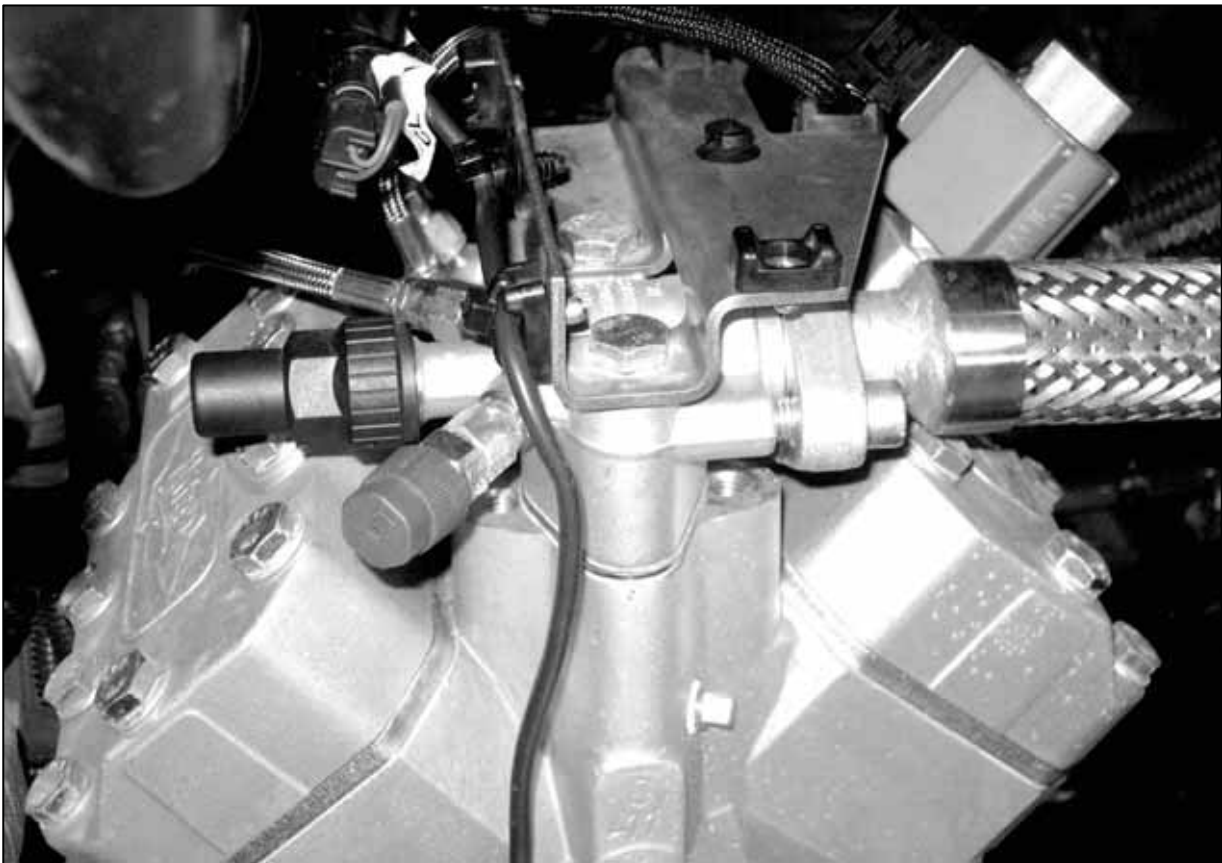

Figure 17 Rear view

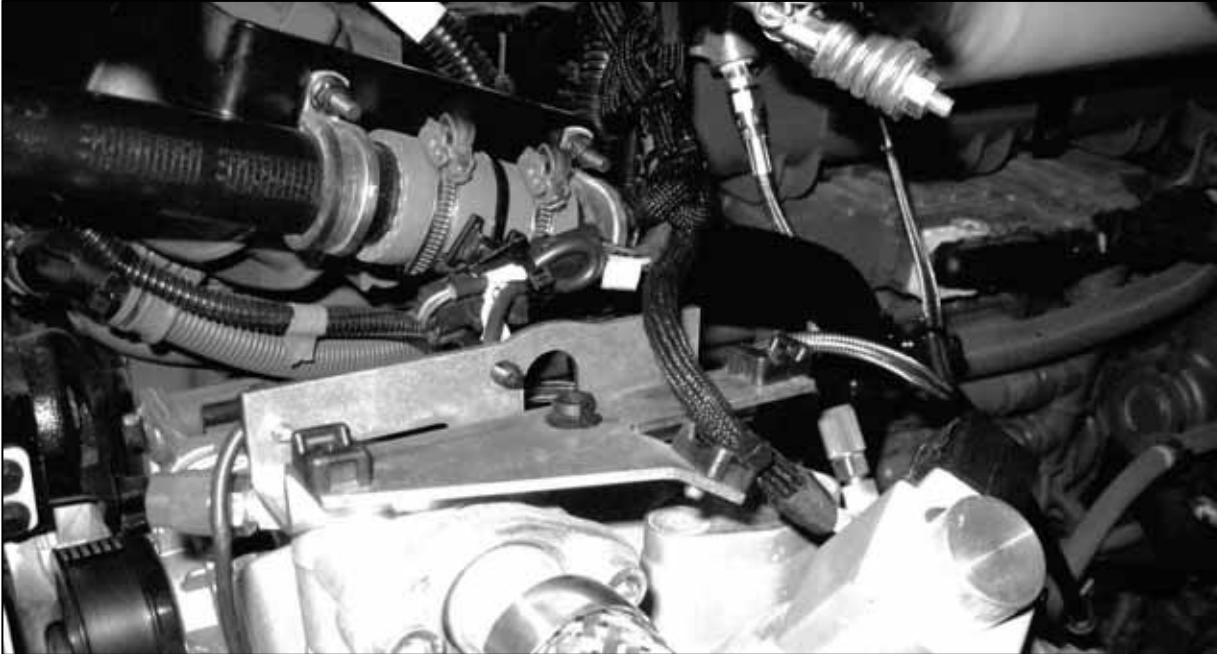

Figure 18 –Right side view

2.11.5. Route harness towards engine by going over the oil fill tube. Add a swivel cable tie base **504751** slightly below flexible section of the oil fill tube. Secure harness. (Fig. 19).



Figure 19

| Date | Expiration | Release | Page |
|---------|------------|---------|--------|
| 09.2014 | 09.2016 | 1 | 17(26) |

2.12. Hose installation

Test airtightness of fitting assemblies and hoses with nitrogen gas **before** installing on vehicle. Use soapy water to reveal any leak.

Install one hose for low pressure remote sensing on port where SE24 was installed, and one for high pressure remote sensing where SE29 was installed. (Fig 20 & 21)



Figure 20

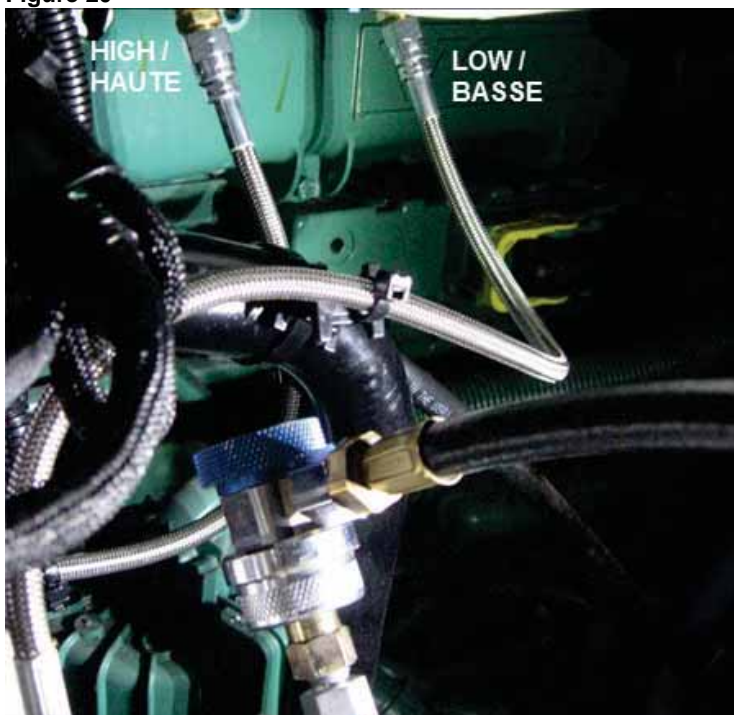

Figure 21

| Date | Expiration | Release | Page |
|---------|------------|---------|--------|
| 09.2014 | 09.2016 | 1 | 18(26) |

2.12.1. Install three swivel cable tie bases **#504751** to secure hoses at following locations. (Fig. 22)

- On oil fill tube, head down, and slightly towards engine.
- On alternator lead, head towards compressor.



Figure 22

- On metal section of oil fill tube, just above the down bend; head up and slightly towards curb side. (Right side) (Fig 23)

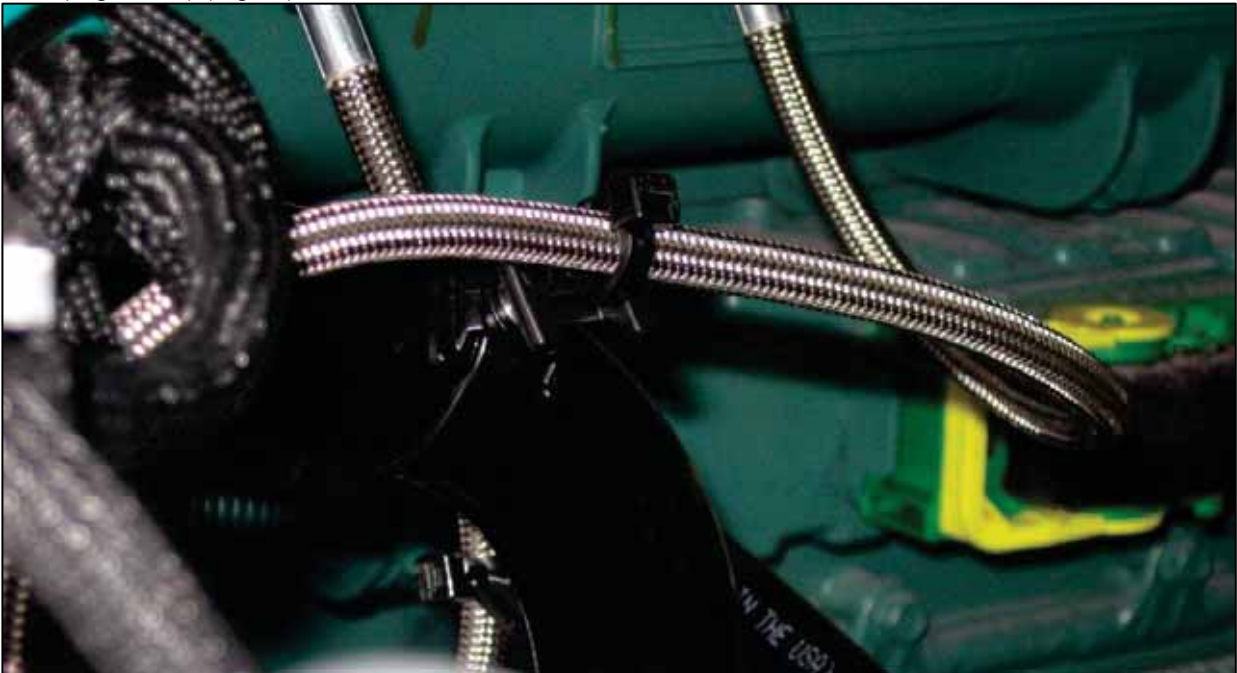

Figure 23

| Date | Expiration | Release | Page |
|---------|------------|---------|--------|
| 09.2014 | 09.2016 | 1 | 19(26) |

2.13. *Connections engine side*

Route harness towards engine and connect to the transducers and switch installed on the fitting assemblies. (Fig. 24) Secure with cable ties.

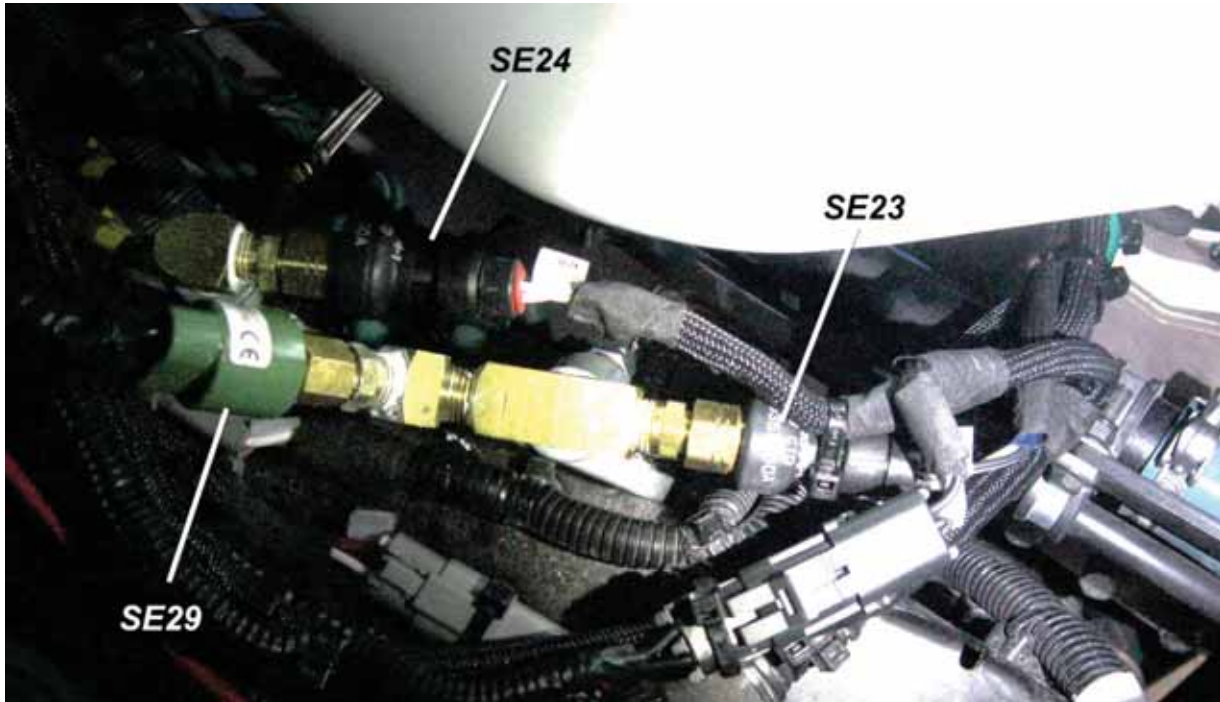

Figure 24 Harness routing to remote instruments on engine.

Connect Harness to C228 and secure connector according to best practices, making sure disconnection is possible.



Figure 25 : SE29 view from rear.

2.14. Returning refrigerant in the system

Make sure system is airtight by vacuum testing.
Recharge system to the appropriate level with the refrigerant recovered earlier.

Ensure refrigerant charge is appropriate in the system.

STEP 3:

Inspect before performing any work.
Some vehicles up to E-5526 may present a gap between the road side air flow splitter, floor and vehicle structure.

To avoid removing the passenger side floor ducts, sealing can be performed from the evaporator compartment.

Add a Sika sealant joint #680532 between discharge duct and structure and between duct and floor.

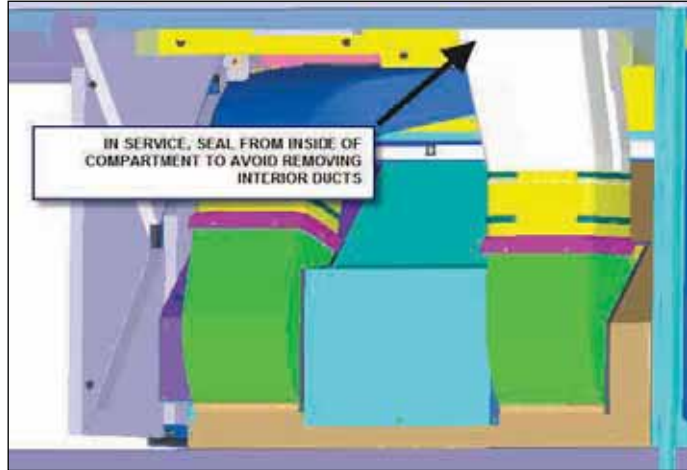

Figure 27



Figure 26

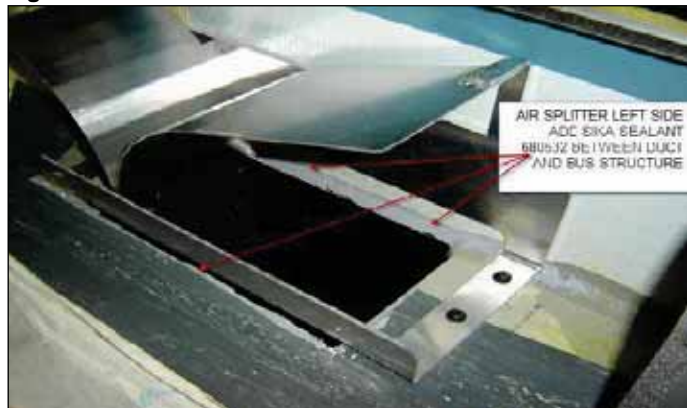

Figure 28

STEP 4:

On the evaporator, inspect the expansion valve bulb position and adjust to 6" from top of brass nut, as indicated in fig 29.

Clean thoroughly the contact surfaces on the tube and on the bulb with a "scotch brite" type scouring pad.

Isolate bulb and tube section with insulating tape #680091.

Verify and update MUX software Version according to table below.

| Model | Mux Soft Version |
|----------------------|-----------------------------|
| H3-41, H3-45 Coaches | 06100060. P10 and up |
| H3-45 VIP Motorhomes | 06100061. P28 and up |
| X3-45 Coaches | 06100058. P11 and up |
| X3-45 Commuter | 06100064. P06 and up |
| XLII-45 Entertainer | 06100061. P28 and up |
| X3-45 VIP | 06100061. P28 and up |

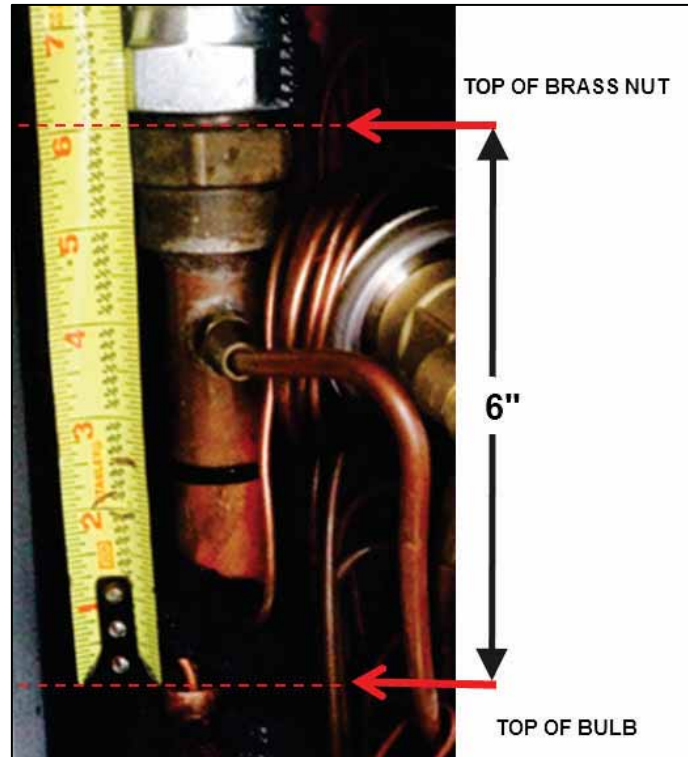

Figure 29

STEP 5:

Perform a dynamic test of the HVAC system confirming the proper operation of the various functions. Repair any leaks prior to starting the tests.

- Check **temperatures** are normal along the system lines, condenser and evaporator.
- Check and adjust **superheat** at evaporator.

Follow guidelines in maintenance manual section **22**, paragraph **9.8** "Expansion Valve - Superheat Adjustment"

- High side and low side **pressure** within acceptable values.
- Confirm proper compressor **unloader** operation.
- Confirm proper **clutch** operation.

Best practices for cable securement and routing

(Source: engineering Spec 20.0)

- Prefer larger cable ties over smaller cable ties in your assembly to limit local pinch effect.
- Avoid sharp edges to prevent chaffing and abrasion.
- Always attach over harness loom or corrugated tubes, not on the bare cables themselves.

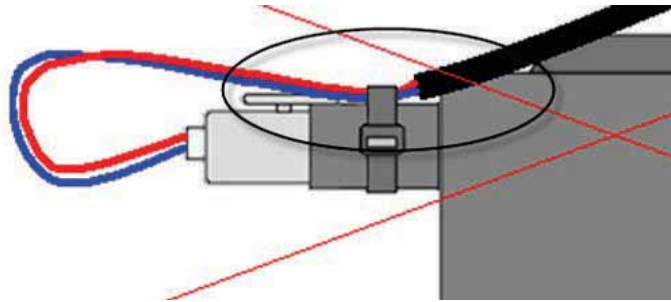

- No over-tightening of cable ties. (Must only prevent harness movement)

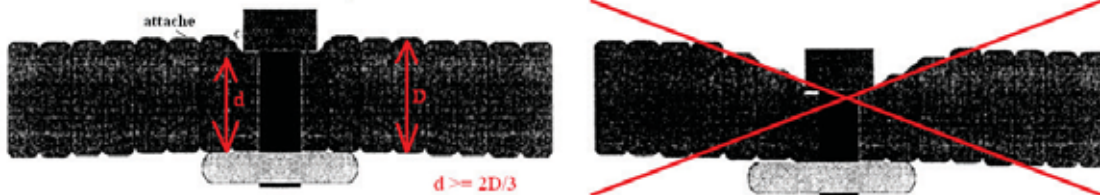

- Perform smart harness routing to prevent water intrusion in the connectors.
(nearest low point: below connector)

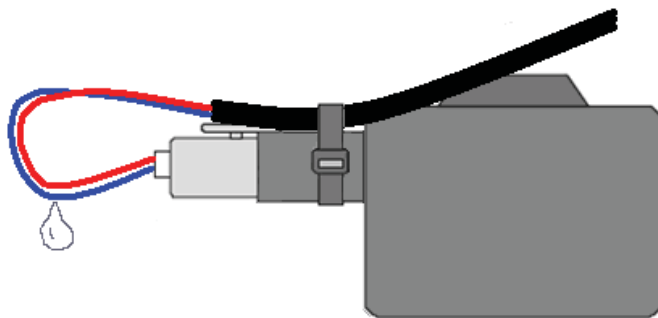

- Also avoid sharp edges of plastic corrugated tubes.

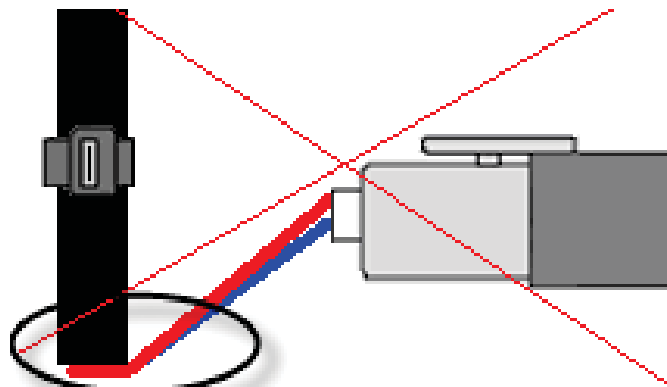

- No pulling or tension on connections.

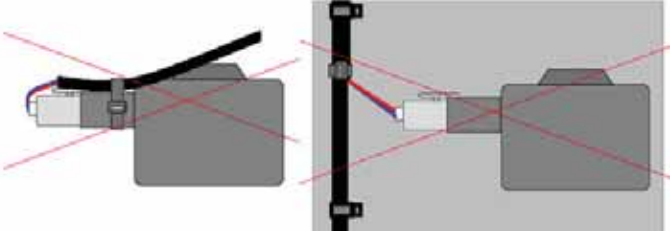

- Avoid sharp radius routing paths. (routing path *inside* diameter = 2 X harness diameter)

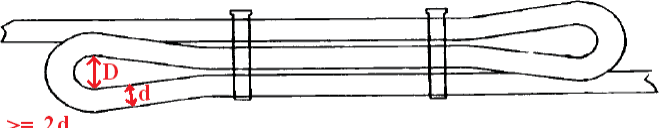

$D \geq 2d$

PARTS / WASTE DISPOSAL

All replaced parts must be returned to Prevest according to the Return Shipping Instructions available on <https://www.prevestcar.com/content/warranty-documents> for full reimbursement. A copy of the warranty claim form must be enclosed with the shipment.

WARRANTY

This modification is covered by Prevest's normal warranty. We will reimburse you the parts and up to 4 hours of labor for Unloader Cap Inspection, Wiring Replacement & Dynamic HVAC Test.

Should the vehicle condition require any of the optional repairs described in Table 1 below, please indicate the step number(s) in the claim description to justify the additional labor time.

Table 1

| Step | Description | Optional Repairs |
|-----------|---------------------------|------------------|
| Step 2.1: | Unloader replacement | 0.25h |
| Step 2.4 | Wire repair / Replacement | 0.5h |
| Step 3 | Duct Sealing | 0.5h |

Please submit claim via our Online Warranty System, available at www.prevestcar.com (under Service \ Warranty section). Use Claim Type: "Bulletin/Recall" and select "Warranty Bulletin SP14-46".

OTHER

| | |
|--------------|--------|
| VBC Bulletin | N/A |
| Fail Code | 22.00 |
| Defect Code | 09 |
| Syst.Cond. | B |
| Causal Part | 950563 |

Access all our Service Bulletins on <http://prevestparts.volvo.com/technicalpublications/en/pub.asp> or scan the QR-Code with your smart phone.

E-mail us at technicalpublications_prev@volvo.com and type "ADD" in the subject to receive our warranty bulletins by e-mail.





Technical Bulletin (TB-0049)

Setting Unloader Cap

Version 1, October 2012

SCOPE

Due to a number of claims relating to unloader caps coming loose, BITZER US, Inc. has developed a procedure for reliably securing the unloader cap to the unloader coil and stem assembly.

Below is typically unloader coil assembly and parts;

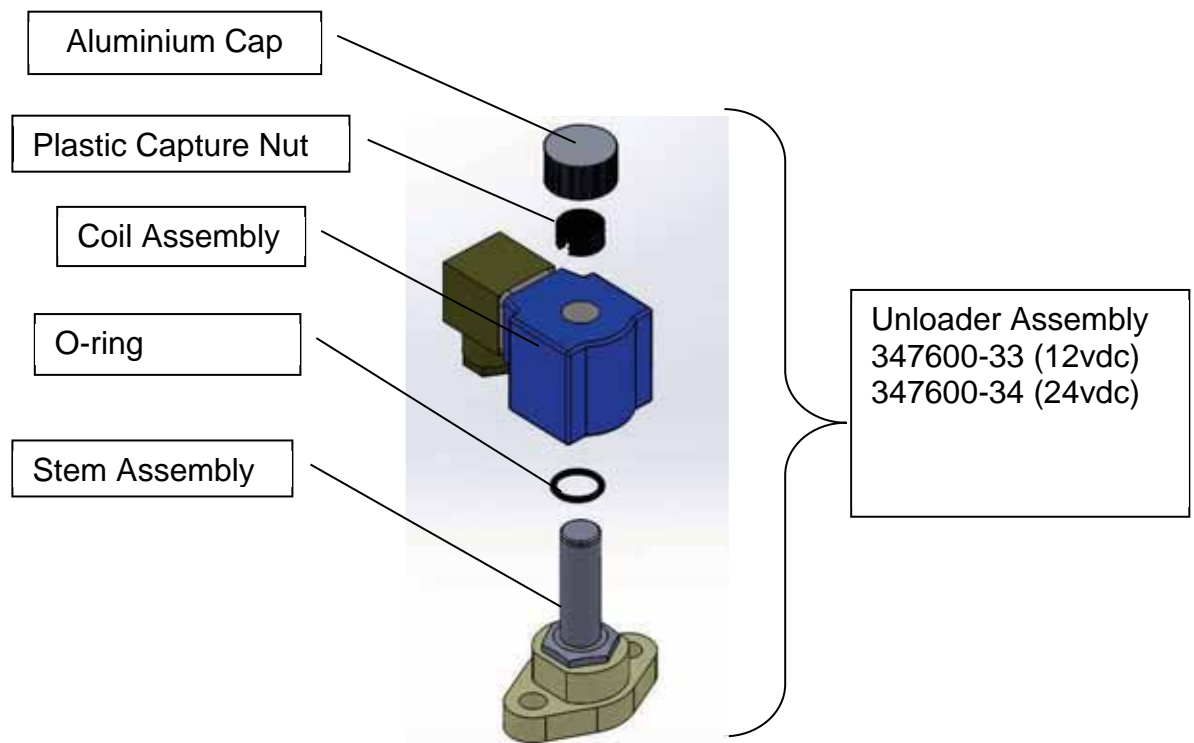

BITZER US, Inc.

4031 Chamblee Rd, Oakwood, GA 30566

Phone: 770.503.9226 Fax: 770.503.9440

www.bitzerus.com customerservice@bitzerus.com techsupport@bitzerus.com

Field Assembly Procedure

Assembly of the coil is a fairly straightforward process. The important point is the position of the coil as assembly and setting the correct torque to keep the cap securely fastened to the stem.

- If the cap comes loose from the unloader assembly it will be necessary to replace to maintain good operating order with the unloader.
 - The replacement part number for new cap components is 375068-02. This will include a new aluminum cap, capture nut and o-ring.
 - All 3 parts should be replaced during the exchange
1. Remove the existing capture nut, coil and o-ring
 2. Install a new o-ring over the stem assembly
 3. Slide the coil over the stem assembly and sit on o-ring
 4. Install capture nut onto valve stem. The capture nut “clicks” in place on the recess of the valve stem.
 5. While holding the coil in the desired position, install and tighten the aluminum cap by hand.
 6. Use the clamp tool and torque wrench to set the final torque on the cap;
 - a. Check torque wrench is set for **3Nm**
 - b. Hold the coil in desired position
 - c. Tighten the cap with the wrench **set at 90° to the clamp assembly** –see Figure 1 below.



Clamp and Torque Wrench Assembly

