

# PREVOST

## Instruction Sheet

## IS-13158

### Keyless Keypad Replacement (Using either kit 069140 or 069141)

#### MATERIAL

Kit # 069140 includes the following parts:

Part No.	Description	Qty
069072	Harness entrance door keyless SKIM	1
069164	Aluminium bracket, SKIM module	1
069167	Harness., Keyless Keypad - Deutsch	1
502868	Screw TC TR PH N500 #10-16 X 1/2	2
502903	Screw TC FL PH N500 10-24X1.25	3
504013	Cable tie mount, black 1/4"	3
504637	Cable tie, nylon black (std)	6
565914	Keypad, door lock w/connector	1
565916	Module, interface keyless system	1
IS-13158	Instruction Sheet EN	1
FI-13158	Instruction Sheet FR	1

Kit # 069141 includes the following parts:

Part No.	Description	Qty
069072	Harness entrance door keyless SKIM	1
069164	Aluminium bracket, SKIM module	1
069166	Harness., Keyless Keypad -CPC	1
502868	Screw TC TR PH N500 #10-16 X 1/2	2
502903	Screw TC FL PH N500 10-24X1.25	3
504013	Cable tie mount, black 1/4"	3
504637	Cable tie, nylon black (std)	6
565914	Keypad, door lock w/connector	1
565916	Module, interface keyless system	1
IS-13158	Instruction Sheet EN	1
FI-13158	Instruction Sheet FR	1

Kit application:

Vehicle type	Vehicle range	Required keyless kit
X Series Vehicles	All	069141
H Series Vehicles	Up to vehicle B-1720	069141
H series Vehicles	From vehicle B-1721	069140

**NOTE**

Material can be obtained through regular channels.

## PROCEDURE



### DANGER

Park vehicle safely, apply parking brake, stop engine and set battery master switch(es) to the OFF position prior to working on the vehicle.

### STEP 1: Removing the Keyless Keypad.

1. Remove the vehicle interior door panel.

**NOTE: Vehicle converter may have installed electronic equipment, lights and custom upholstery on the door panel, refer to the converter instruction for proper removal procedure.**

2. Inside the door, locate the door opening mechanism and disconnect the door locking bar from the bracket.

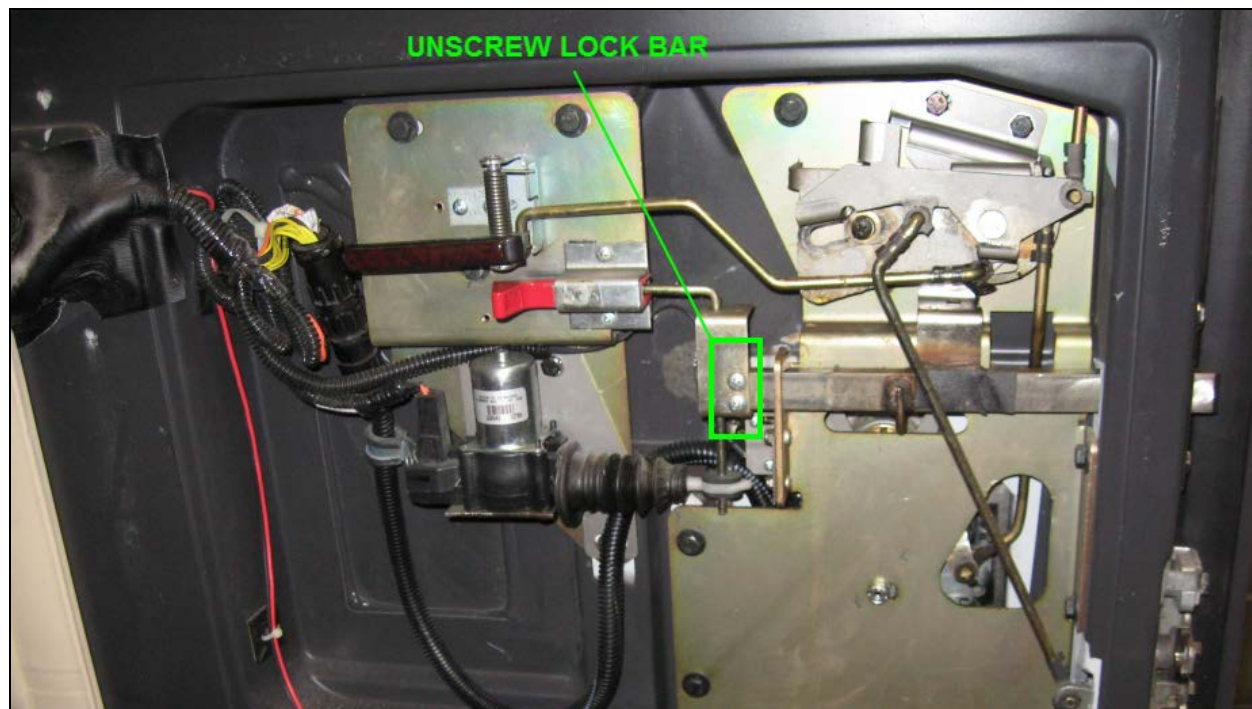

3. Disconnect the two wires behind the locking bar bracket.



4. Remove the P-clamp holding the harness to the door and disconnect the harness.

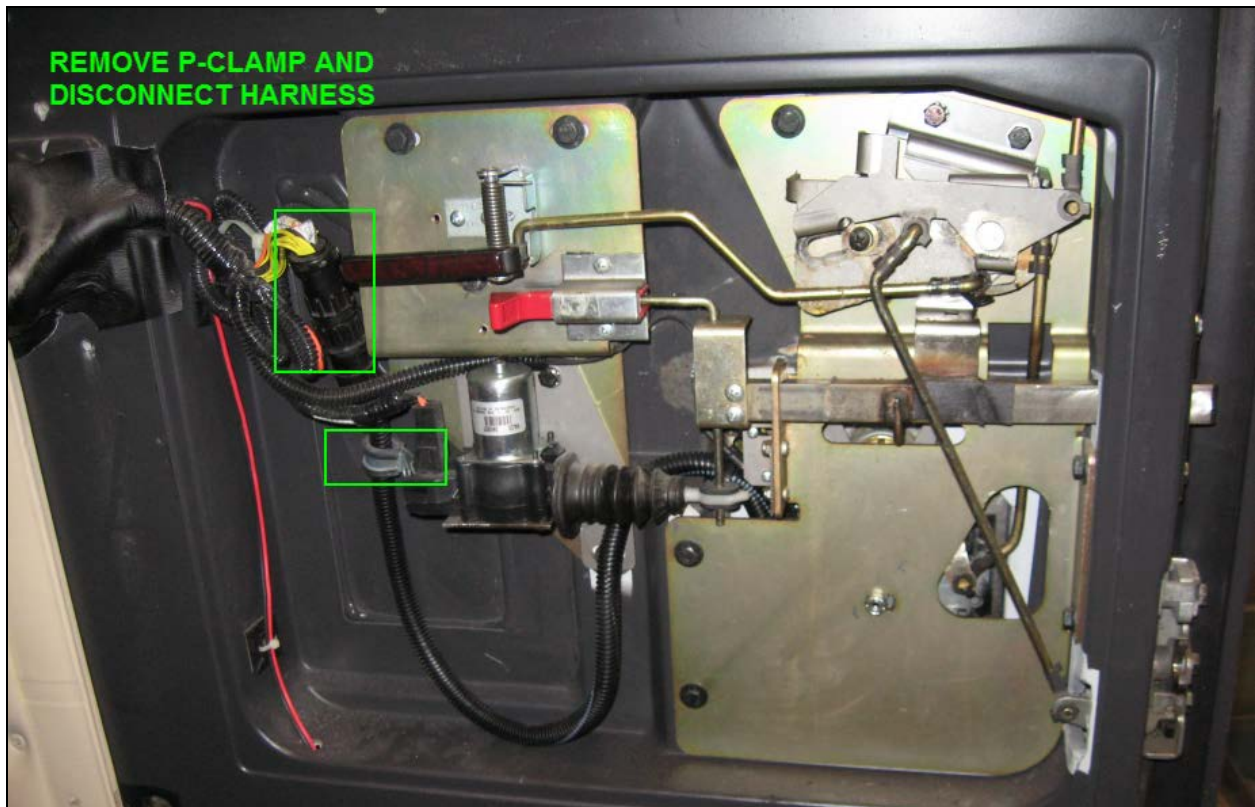

5. Disconnect one end of the four (4) actuator arms from the door mechanism as shown in the picture below.

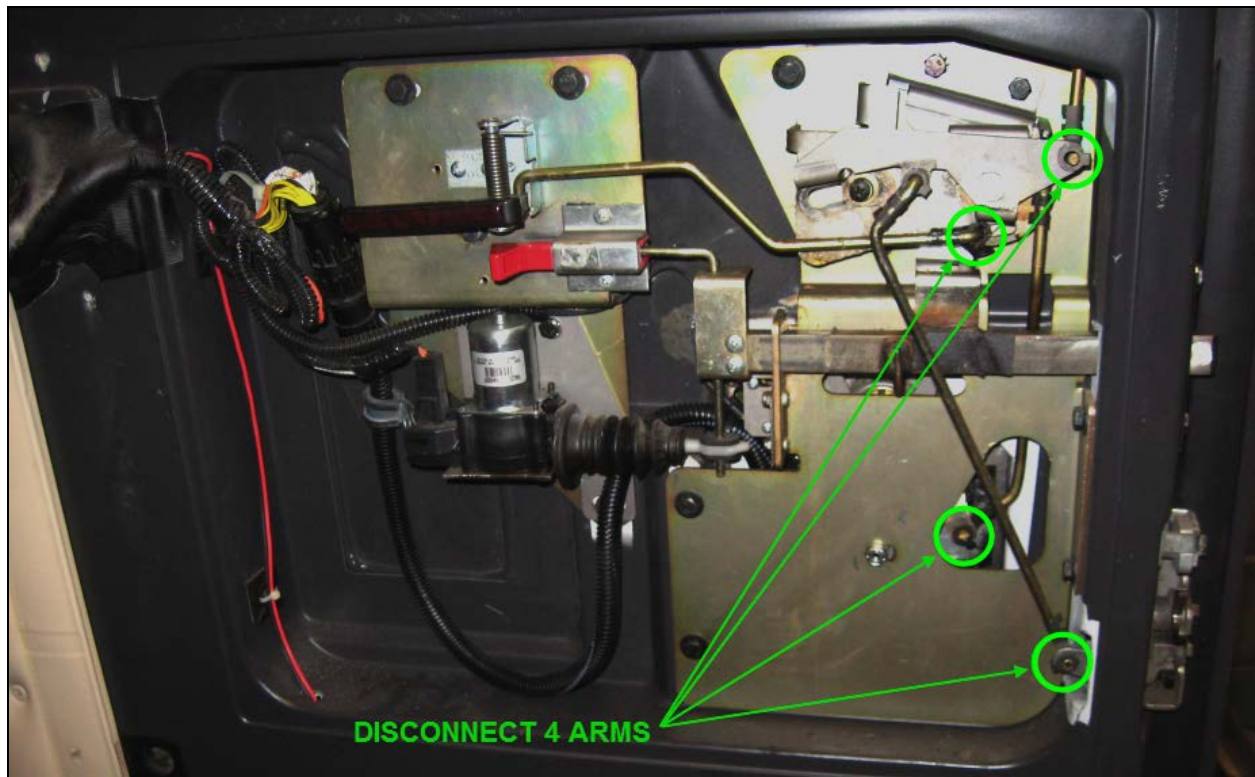

**NOTE**

The actuator arms retaining clips are left and right handed, It is recommended to “clip” them back on the arm until reinstallation to avoid mixing them.

Removing arm clip:



Arm and arm clip reinstallation (insert clip first):



6. Unscrew the five (5) mechanism back plate retaining hex screws and the center lock nut, remove the mechanism from the door.

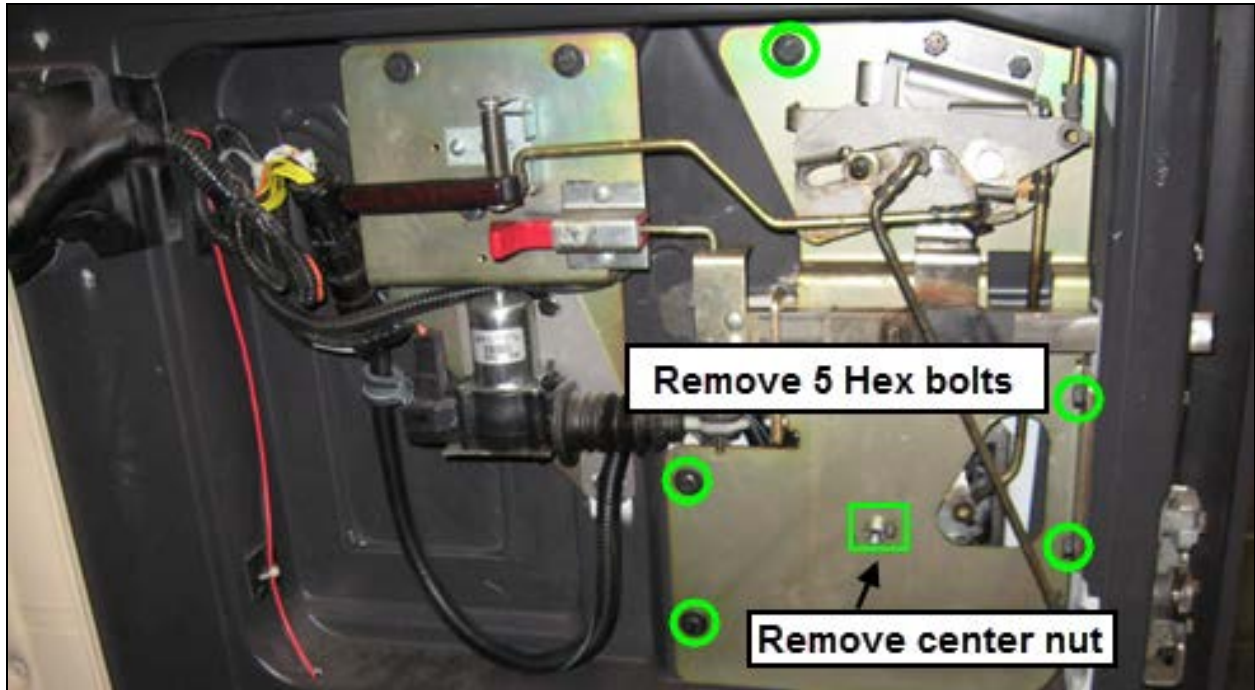

7. With the mechanism back plate out of the way, locate the keyless module backside and remove the retaining clip by sliding it out of the module as shown.

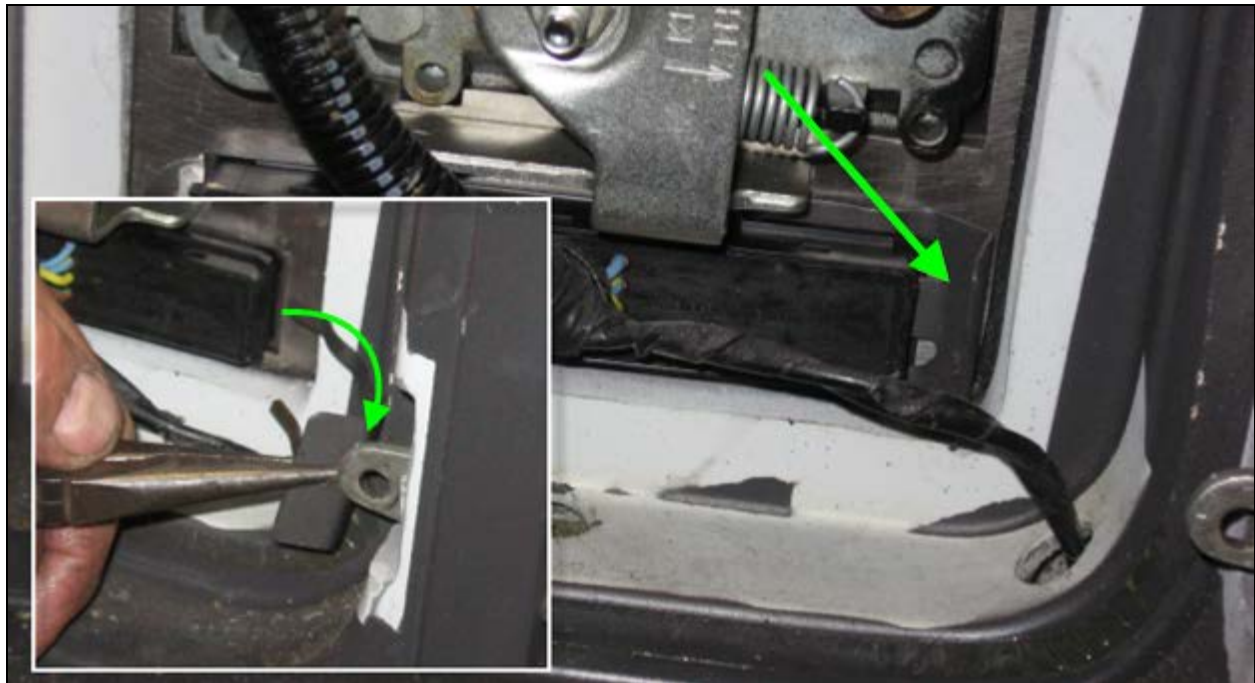

8. In the door lower lamp recess, disconnect the clamp that holds the harness part connecting to the lamp (lamp was removed with the door panel).

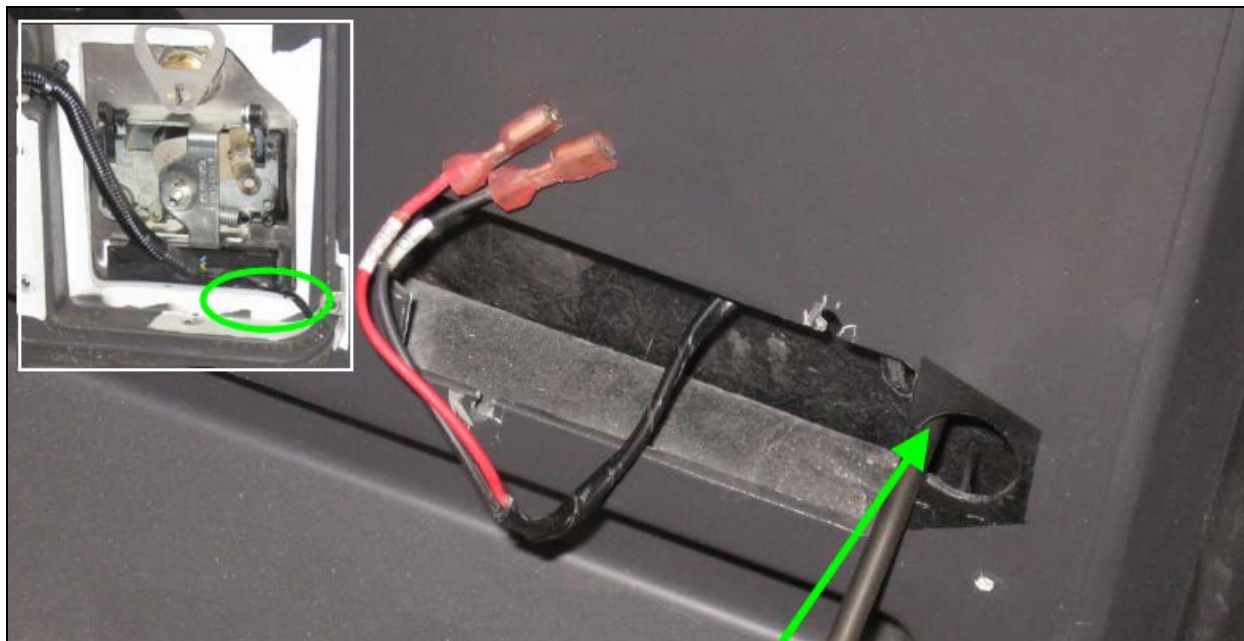

9. The keyless module and harness can now be removed from the outside of the door.

### STEP 2: New Keyless module connection.

10. Insert the new keyless module in the door opening and lock it in place using the retaining clip previously removed in part 1 step 7.



11. The new keyless module does not have a wiring harness attached to it like the older version. The keypad harness supplied with the kit must be connected to it and the other end of the harness reconnected to the vehicle door harness.

**NOTE: Kit 069140 includes # 069167 rectangular connector harness (Deutsch connector type) and kit 069141 a round CPC type connector # 069166 (see chart on page 2 for the proper kit selection).**

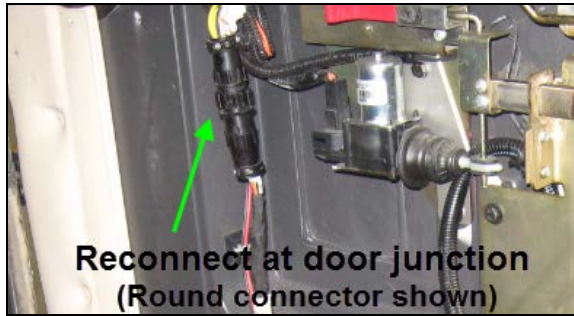

12. Reinstall the P-Clamp that holds the harness in place at the door connection.

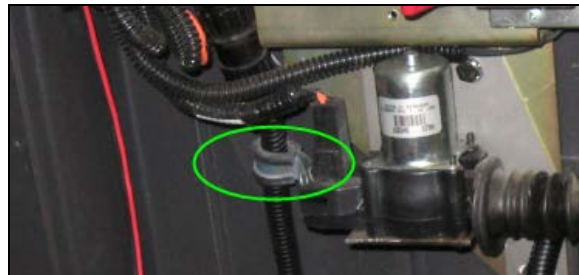

13. Route the lamp part of the harness inside the door frame toward the lower lamp recess and reinstall the wire clamp.

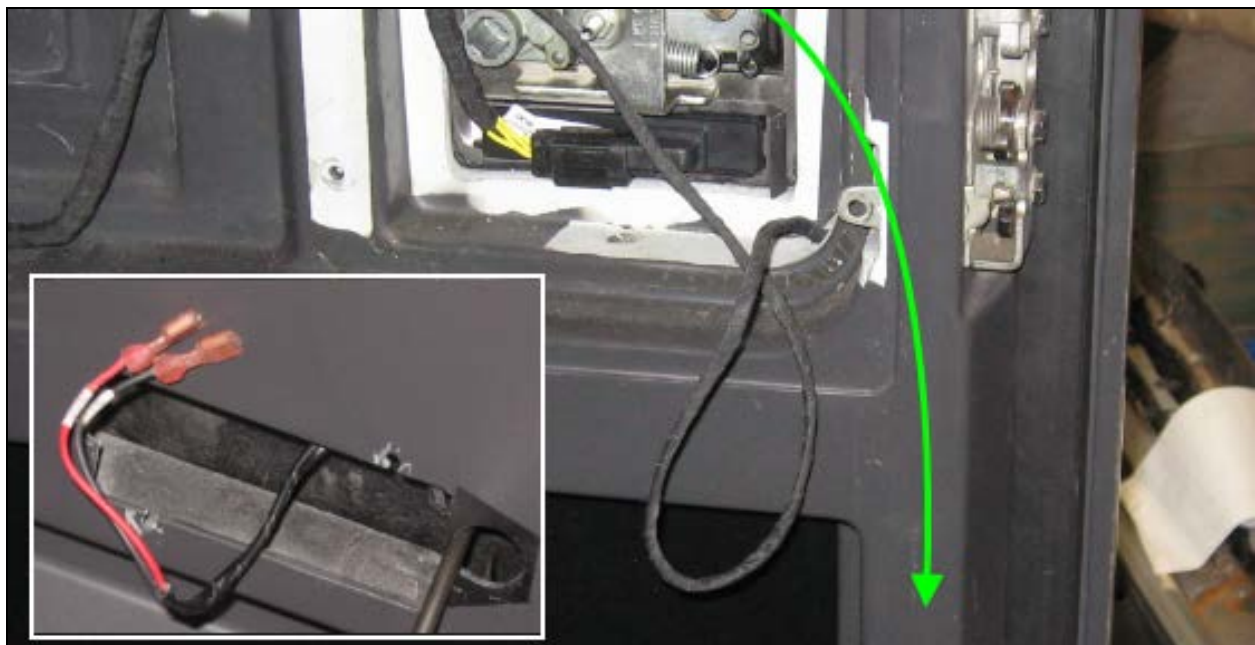

- Put back the door mechanism back plate in position and *hand tight* the center hex nut. Do not install the others hex nuts yet.

**NOTE:** Insert the locking bar in its bracket before tightening the hex nut.



- Connect the two wires behind the bracket and tighten the locking bar screws.

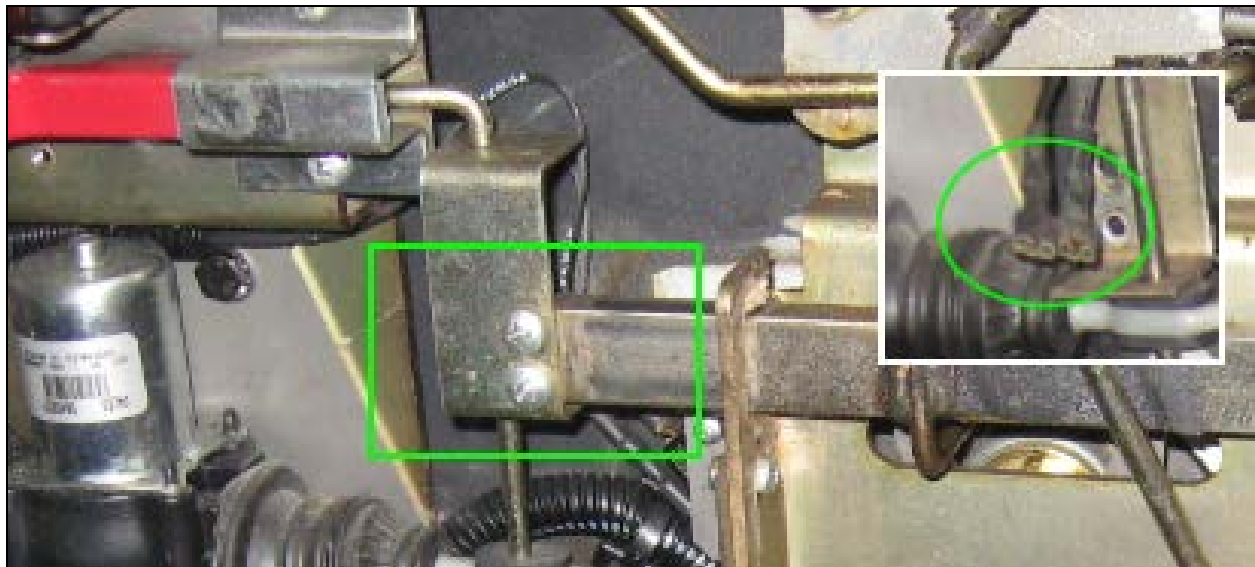

16. Reinstall the four (4) actuator arms in the order shown below

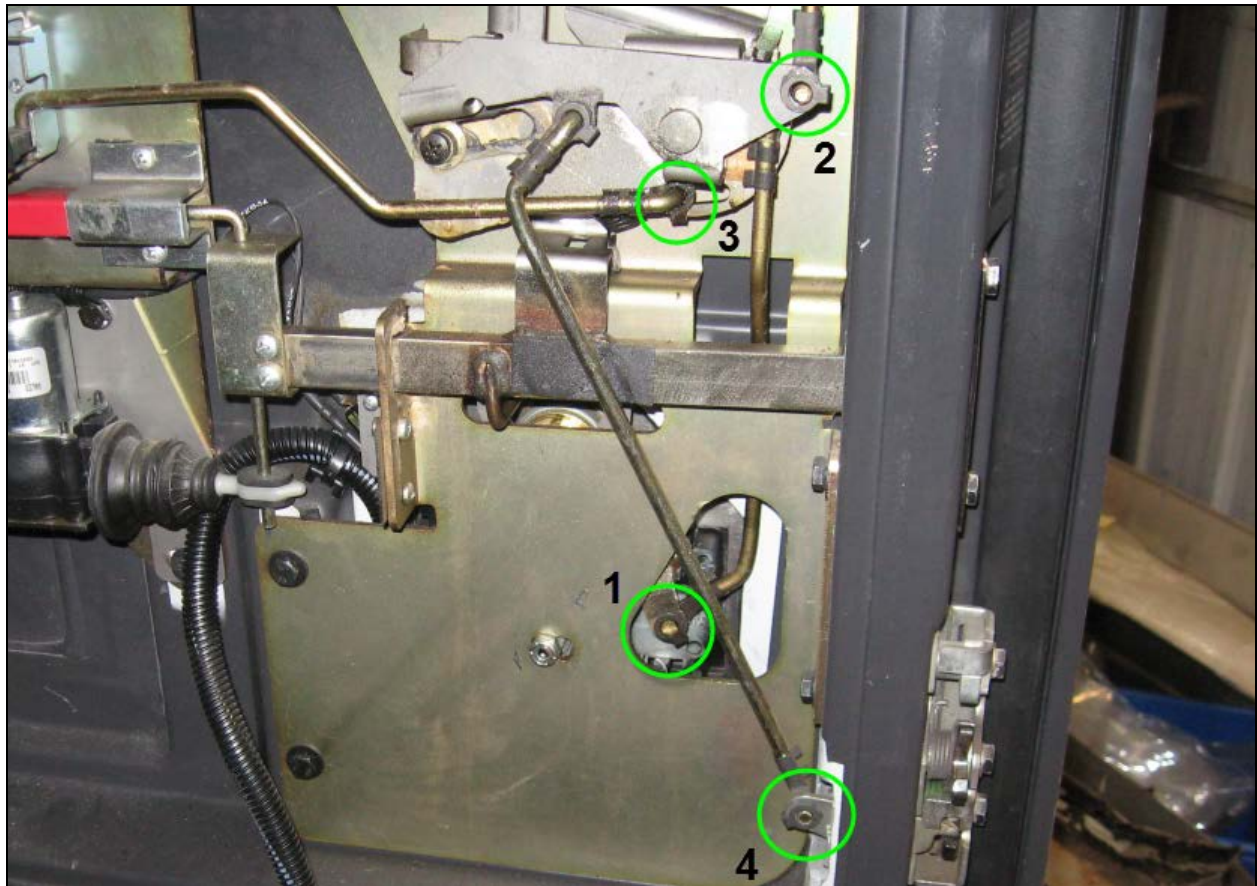

17. Reinstall the five (5) hex nuts around the mechanism back plate and tighten the center nut.

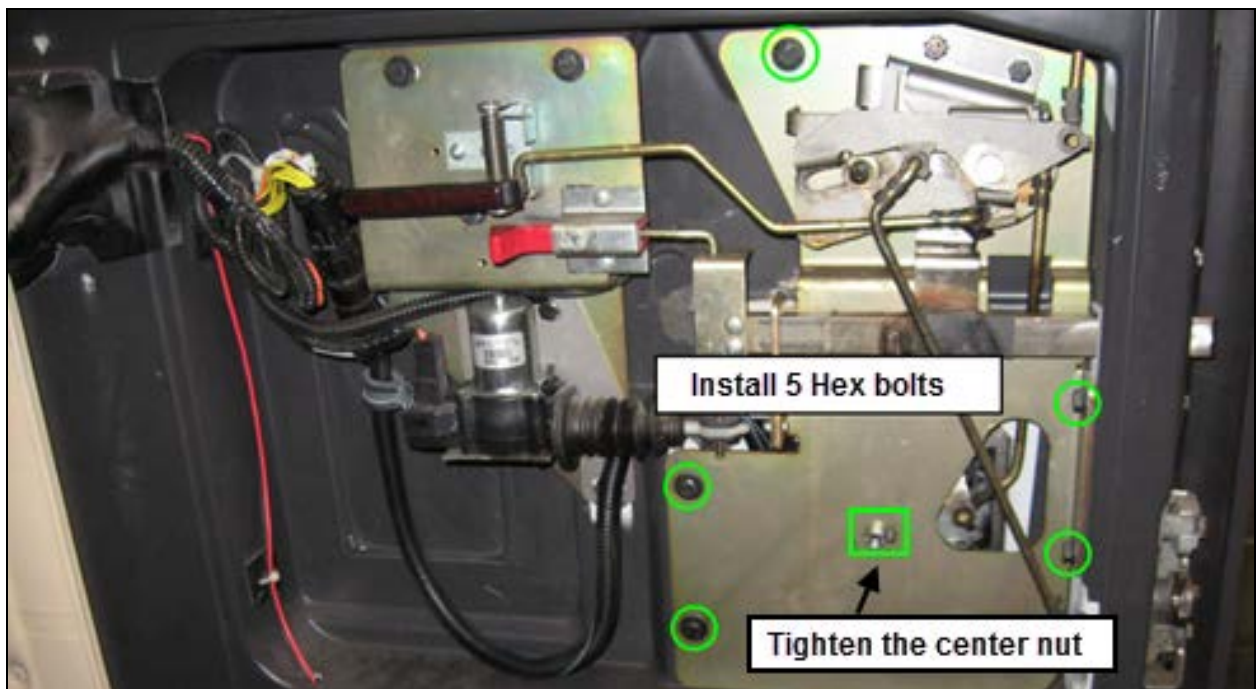

### STEP 3: SKIM Module connection.

#### **Keyless Module location :**

It is recommended to install the SKIM interface module as close as possible to the vehicle Keyless Module.

The Keyless Module can be found in different location on the vehicle depending on the vehicle management system.

For pre-multiplexed vehicles (pre-MUX), the module is located under the vehicle dashboard.

For multiplexed (MUX) vehicles, the module is located in the front electrical compartment.

- H Series Multiplexed vehicles VIN from 6-0436

- X Series Multiplexed vehicles VIN from 7-9096

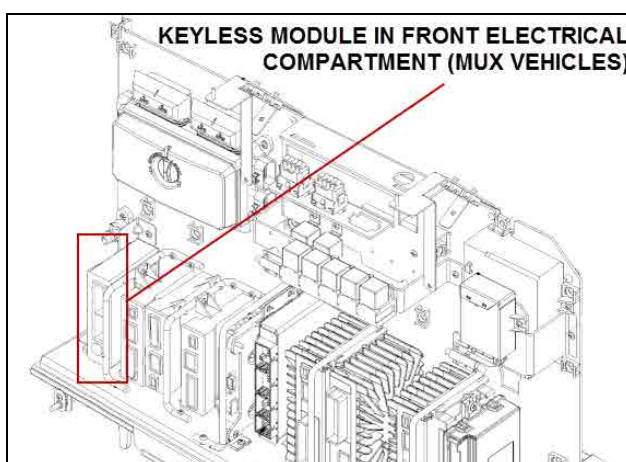
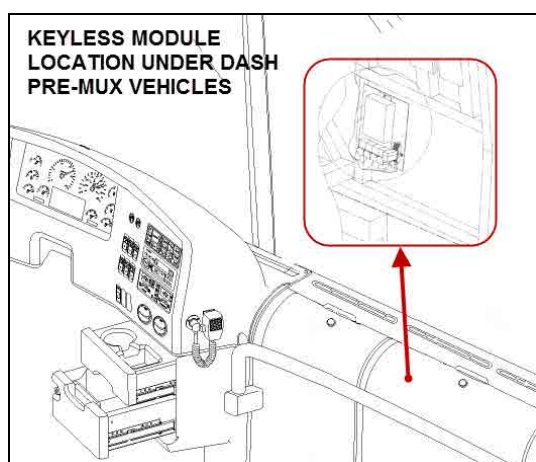

**NOTE:** Some early MUX vehicles may had their Keyless module installed at the opposite end of the module bank in the engine compartment

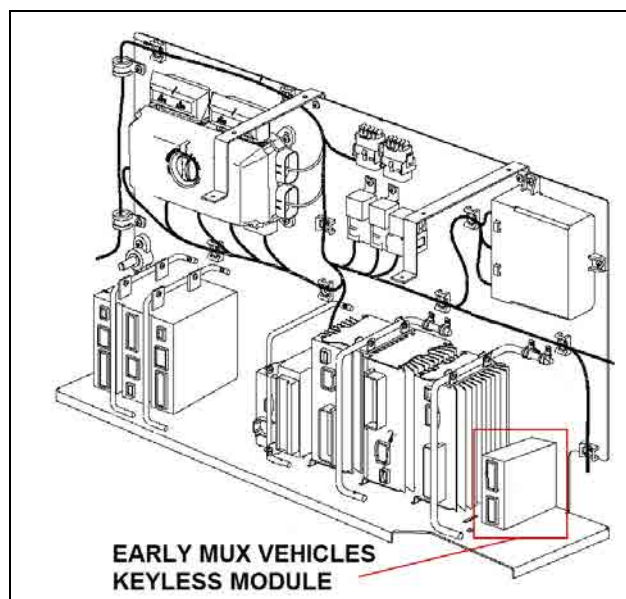



## CAUTION

The following steps will require cutting wires from the vehicle wiring harness. Double check that the battery master switch(es) are set to the OFF position prior to working on the vehicle.

**NOTE: Complete wiring diagram of the installation is provided at the end of the procedure**

18. Locate the keyless module on the vehicle (refer to the module location information on page 10).

19. At the module connection plug, identify the five yellow wires numbered 272, 274, 276, 278 and 280.

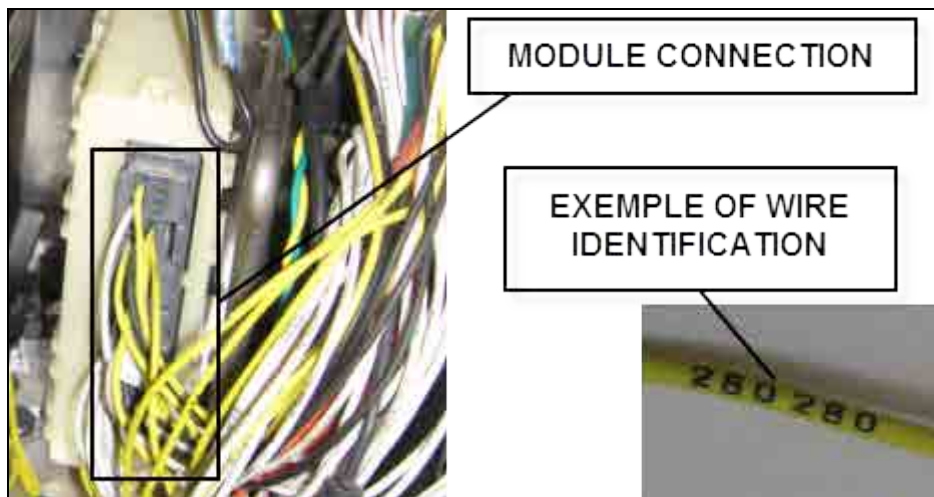

20. Cut the wires leaving a minimum of six inches at the back of the plug.

21. Strip the 5 wires at the plug end.

22. Strip wires 272, 278 and 280 at the vehicle harness end.

23. At the harness end, apply shrink tubing to protect the ends of wires 274 and 276, they will not be reused.

24. With the help of the pictures below, identify the 069072 harness connectors.

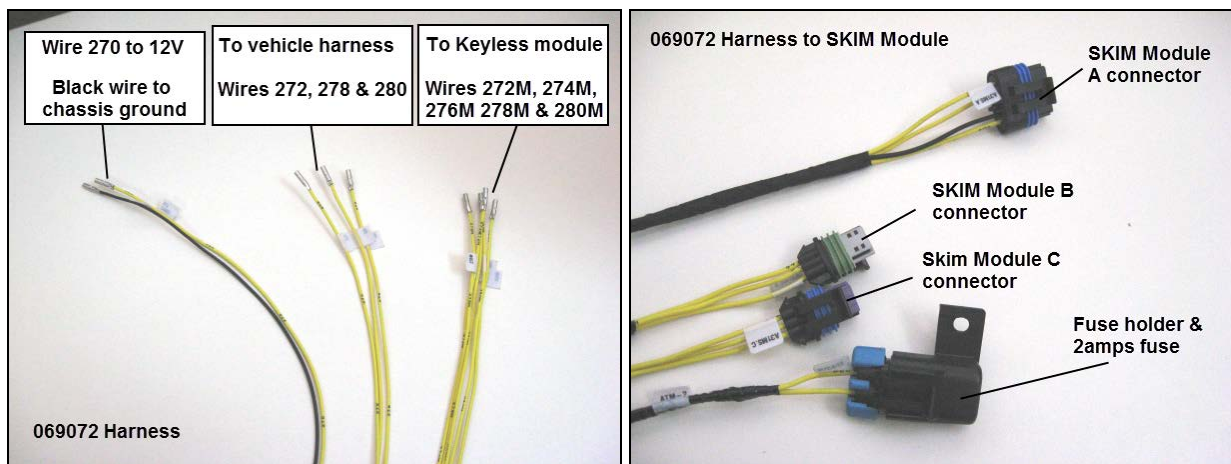

25. Connect (crimp & solder) the five "M" wires coming from the 069072 harness with their corresponding wires at the module end as shown below.

**NOTE: It is strongly suggested to *crimp & solder* all connections to ensure that they do not loosen or corrode over time.**

**Also use the provided *heat shrink tubing* to fully insulate all connections made to the vehicle harness.**

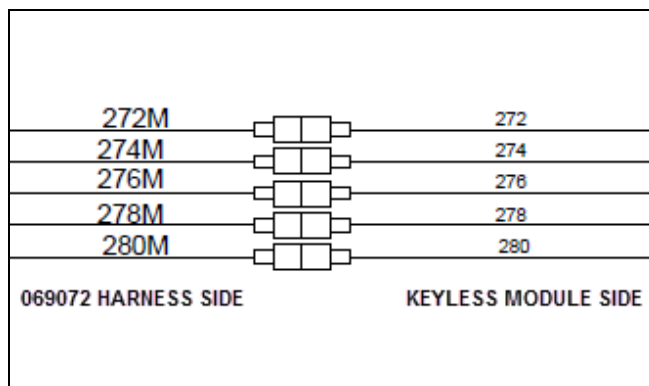

26. Crimp & solder wires 272, 278 and 280 of the 069072 harness to their corresponding wire at the vehicle harness end (use provided heat shrink tubing).

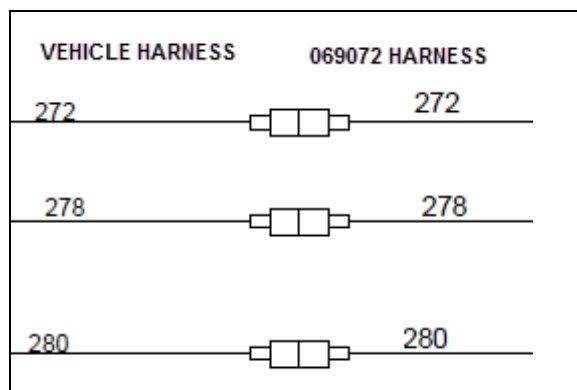

27. Connect (crimp & solder) the 270 (12VD2) wire of the 069072 harness to a suitable 12V direct spare wire on the vehicle harness (alternatively, it is possible to get a new power source directly from the front junction box using insulated 18ga wire).
28. Connect the 069072 black wire to a suitable vehicle electronic ground wire (wire may be numbered 0L or 00A). It is also possible to connect the wire directly to the front junction box ground.
29. Install the SKIM module as close as possible to the keyless module using the supplied aluminum bracket (069164) and mounting screws (502868 & 502903). Test the fit of the installation and make sure that sufficient space is provided at both ends of the module to allow the 069072 harness to be connected without creating sharp bends in the wiring.

Typical MUX (front electrical compartment) and pre-MUX (under dash) installations are provided below for reference purpose.

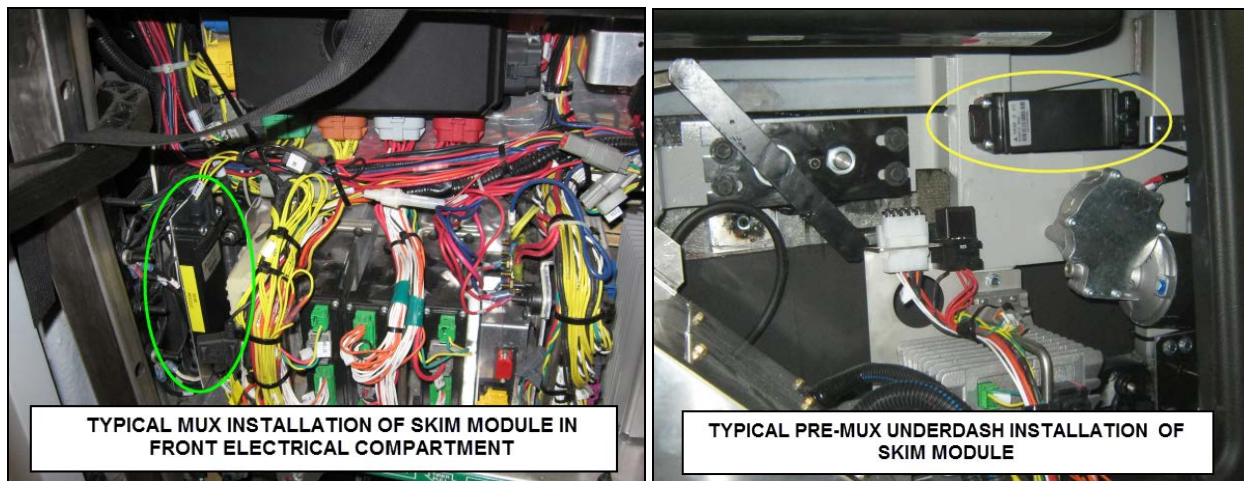

30. With the SKIM module installed on the vehicle, connect the tree (3) 069072 harness connectors (A, B & C) to their respective module connection as shown below (connectors plugs are all different to prevent misconnection).

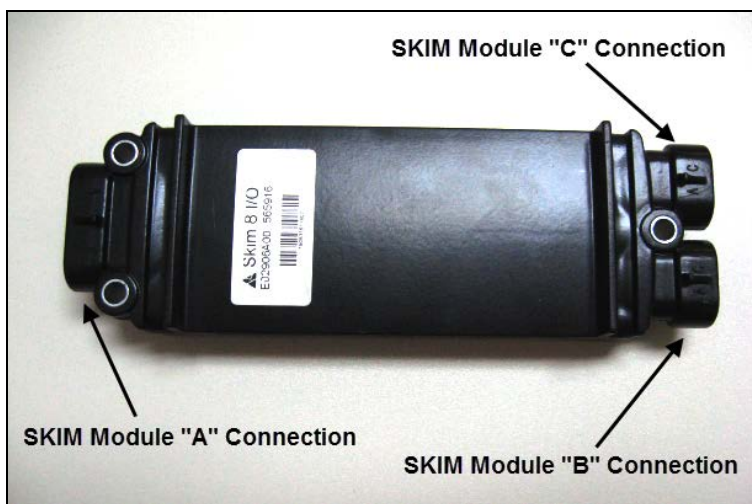

31. Using the supplied nylon cable ties, attach the 069072 harness to the vehicle existing harness so it will not hang or rub against the vehicle chassis or moving parts (screwing the fuse holder to the chassis is recommended).
32. Set the battery master switch to the ON position, lock and unlock the door a few times to test the installation. If the locking mechanism functions properly, reinstall the door panel and accessories to complete the installation

## **PARTS / WASTE DISPOSAL**

Discard waste according to applicable environmental regulations (Municipal/State[Prov.]/ Federal)

