

## LA 45 COMPO: Surge Tank Mount



**Prepared by:** Kalman Takacs  
Field Service Engineer  
Phone (256) 241-1243  
Fax (256) 832-0930

**Approved by:**

**Property name and top bus number:** LA 45CLFW, 95000, 218000, 269000



**Issue:** Surge tank mount.

**Reason/ cause:** During the production of the Compo buses, many type of surge tanks were used. Two different mounts were used to secure surge tanks to the top of the radiator. In order to install the latest surge tank on an old Compo bus, some minor modifications may require.

**Solution:** Install latest surge tank on an old Compo bus per this work instruction.

## LA 45 COMPO: Surge Tank Mount



**Number of affected buses:** As required

**Estimate repair hours/bus:** 2 hours

**Necessary parts:**

Surge tank, square, NABI Part #: **50A-1313-001**, 1 / bus,

**Note:** this surge tank is suitable replacement for **801-1313-000** tank on Metro Compo 8000 series bus. This surge tank also suitable replacement of **505-1313-001** surge tank (with three isolator mounts) and **506-1313-001** surge tanks (with four isolator mounts) however a slight modification is required on the radiator bracket. Please follow the instruction below.

**Necessary tools:** Usual hand tools (wrenches, sockets, screwdrivers, etc.), bucket to drain coolant.

# LA 45 COMPO: Surge Tank Mount



## SAFETY PRECAUTIONS MUST BE FOLLOWED ACCORDING TO ACCEPTED INDUSTRY STANDARDS AND LOCAL/PROPERTY REQUIREMENTS.

1. Park the bus on a flat surface and apply the parking brake.
2. Open engine compartment access door.
3. If surge tank needs to be replaced then follow safety precautions described at sections 9A and 9B of NABI Maintenance Manual. Let coolant (engine) cool down before performing the repair. Release pressure from surge tank before open the pressure cap.
4. There are two type of surge tank installations on the Compo:
  - On the 8000-8099 buses, the surge tank was installed with three rubber donuts (see item #6 below).

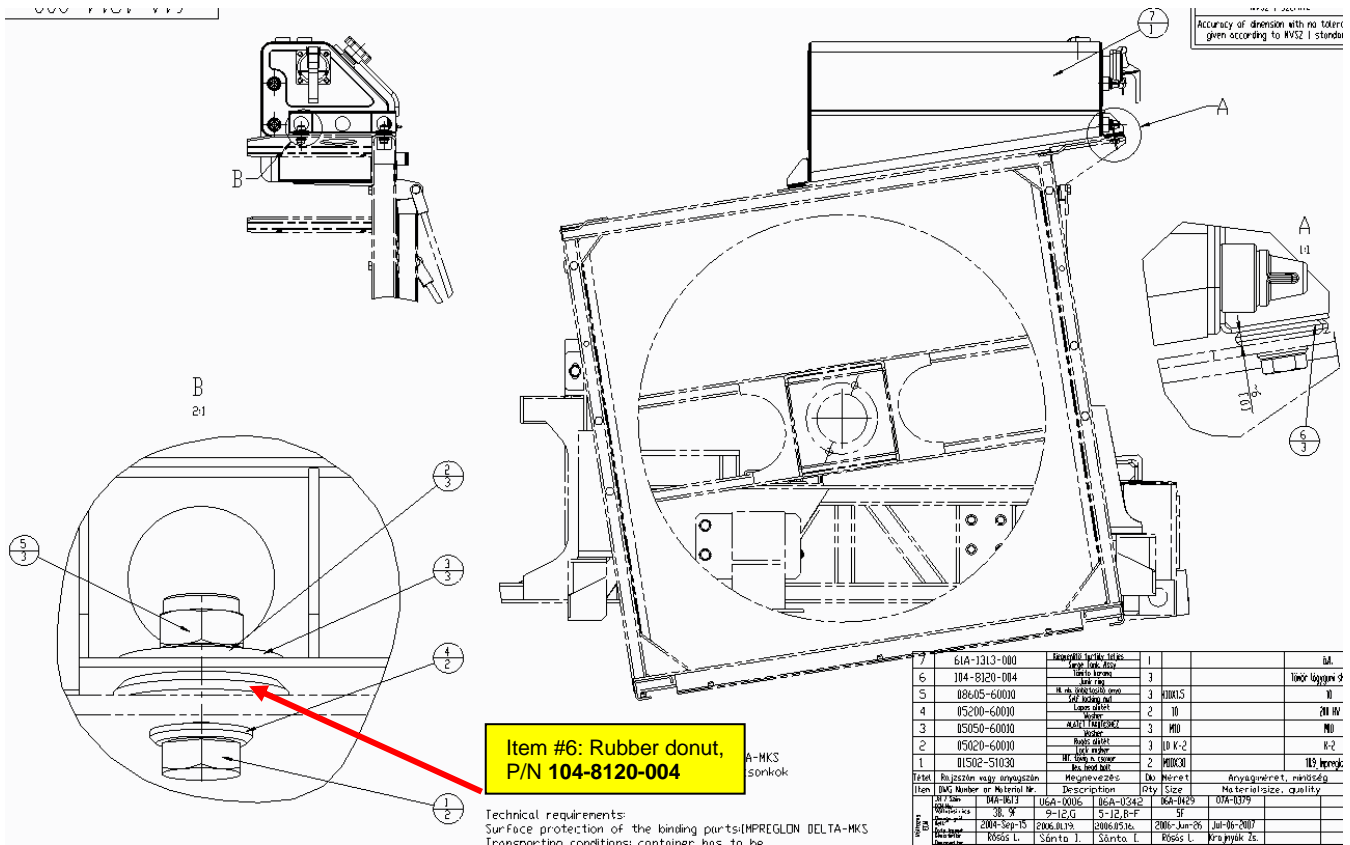

7	61A-1313-000	Kiegészítő tartály teljes Surge Tank, Assy	1			ö.A.
6	104-8120-004	Tömítő korong Junk ring	3			Tömítő lágygumi shore 60
5	08605-60010	Hl. mk. önbiztosító anya Self locking nut	3	M10X1.5		10
4	05200-60010	Lapos alátét Washer	2	10		200 HV
3	05050-60010	ALÁTÉT FAKÖTÉSHEZ Washer	3	M10		M10
2	05020-60010	Rugós alátét Lock washer	3	10 K-2		K-2
1	01502-51030	Hlf. tövög m. csavar Hex. head bolt	2	M10X30		10.9_Impreglon

## LA 45 COMPO: Surge Tank Mount



- Later NABI used surge tanks with three or four rubber isolators on bus # 8100-8400.

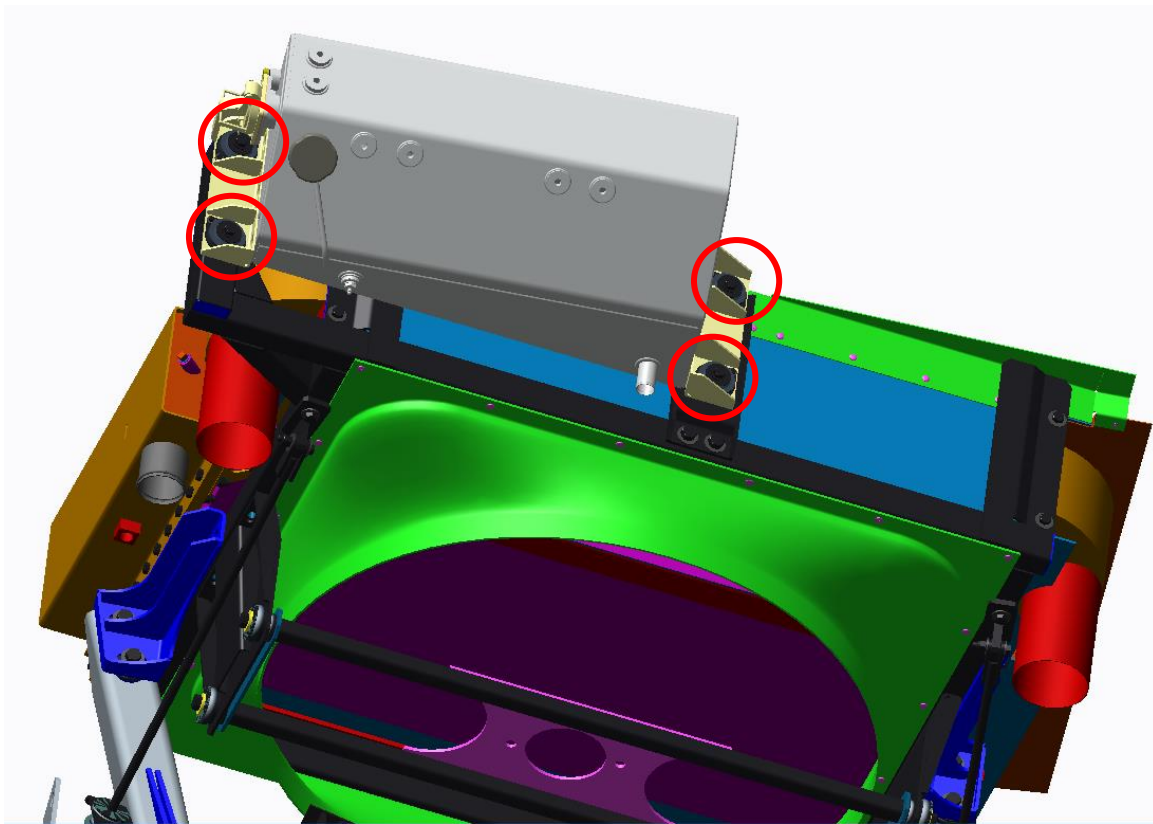
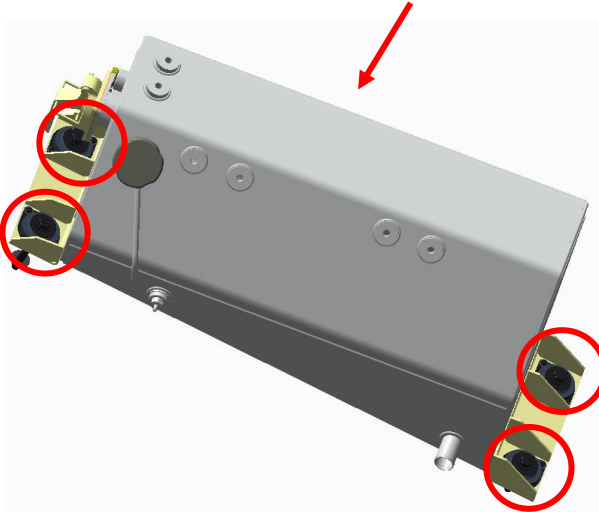

## LA 45 COMPO: Surge Tank Mount



5. The latest heavy duty “square” surge tank design (PN **50A-1313-001**) has the same mounts as the first original design (no isolators). This new square surge tank is interchangeable with the older version of square surge tanks (on bus # 8000-8099). On 8100-8400 Compo buses where three or four rubber isolators were used to secure the original square surge tank, follow the instructions below in order to install the new surge tank.

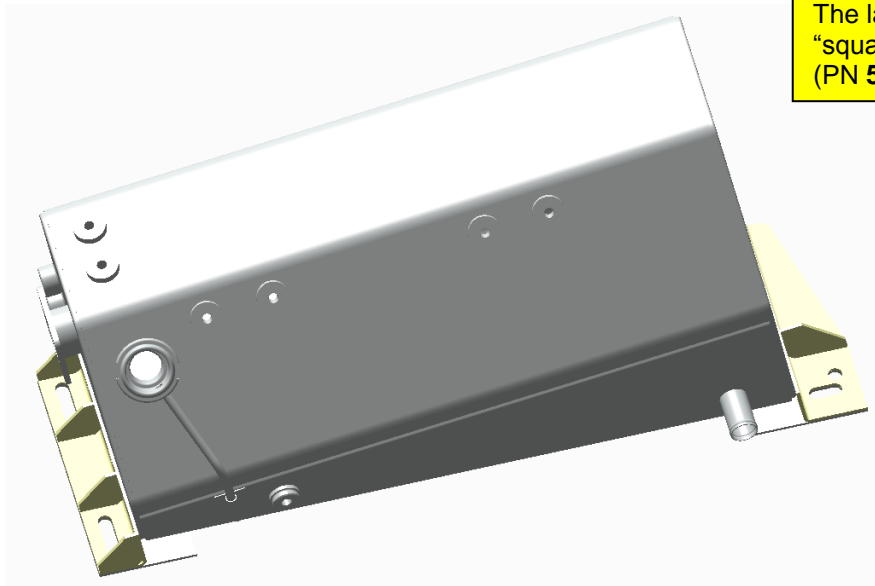

6. Drain coolant from surge tank.
7. Disconnect hoses and low coolant sensor harness from surge tank.
8. Remove 3/8-16x4 bolts, nuts and washers at the four isolator mounts.

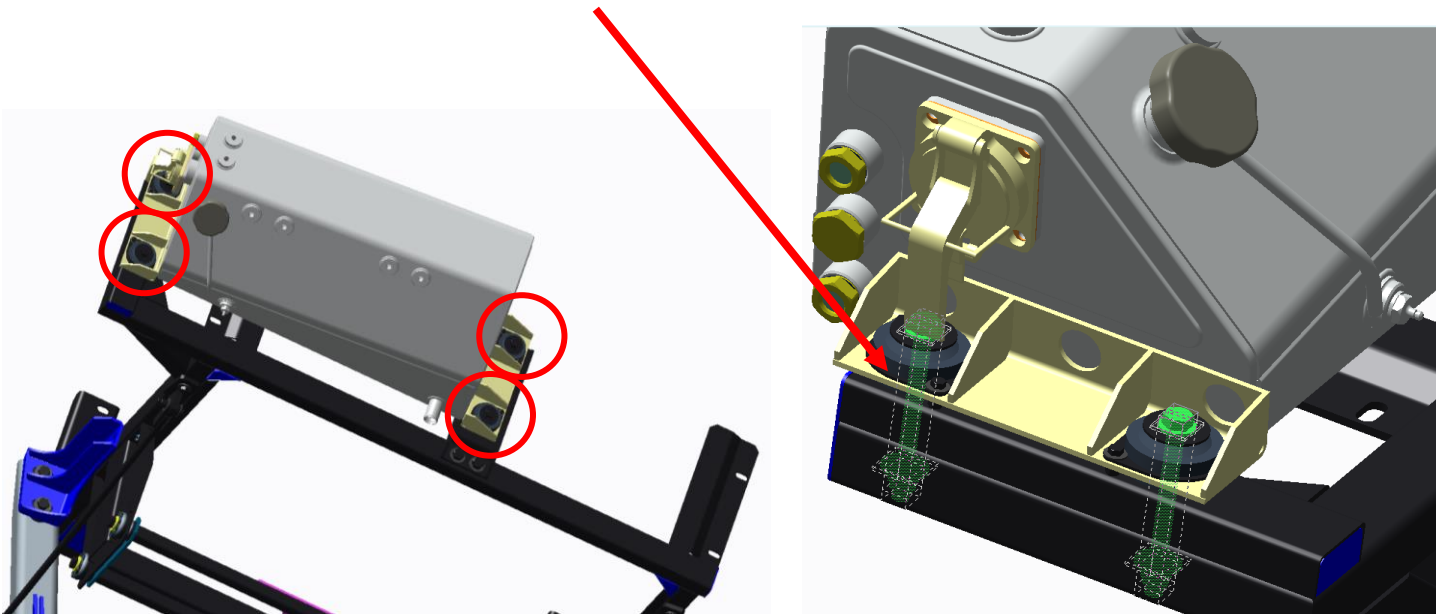

9. Remove surge tank together with four isolator mounts.

## LA 45 COMPO: Surge Tank Mount



10. Remove two mounting bolts of forward bracket then remove bracket from radiator. Save one set of mounting hardware for the new surge tank installation.

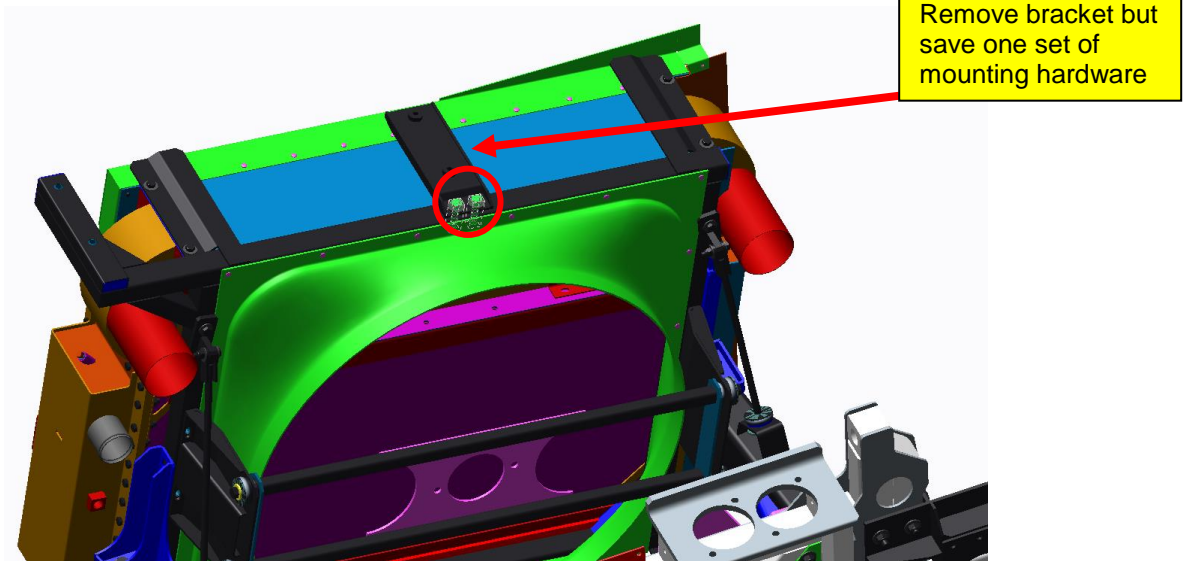

11. Position new surge tank over the existing holes (see red arrows below).



12. Place rubber donut (item #6 on the drawing at page 3) between the mounting holes of the frame and the surge tank.
13. Install new surge tank with the original 3/8-16x4 bolts, nuts and washers at the rear two mounts and with bolt, flat washer (that were secured the forward bracket) at the forward mount.
14. Tighten mounting hardware gently to prevent stress on surge tank.

## LA 45 COMPO: Surge Tank Mount



15. Reconnect hoses, vent lines, and reinstall low coolant sensor and harness. Ensure that the harness and/or vent lines are not rubbing other components. The vent lines must continuously raise towards the surge tank. Ensure that the vent lines are not kinked.
16. Refill surge tank.
17. De-aerate cooling system per section 9A of NABI Maintenance Manual.
18. Check for completeness of work.
19. Record fleet # and mileages.
20. Inspect coolant level and check for leaks periodically per NABI Maintenance Manual.