

Initialization of Parking Assist Monitor System

Service Category General

Section Pre-Delivery Service

Market USA

Lexus Supports
ASE Certification 

Applicability

YEAR(S)	MODEL(S)	ADDITIONAL INFORMATION
2015	GX460	

Introduction

The Parking Assist Monitor System assists the driver during parking and parallel parking by displaying an image of the area behind the vehicle.

When the Short Pin is removed or battery terminal is disconnected, the power source to the steering angle sensor is cut off. When the Short Pin is reinstalled or the battery terminal is reconnected, the rear view monitor will operate, but it cannot display guidelines to assist parking operation until the system has been initialized.

Initialize the Parking Assist Monitor System after installing the Short Pin during Pre-Delivery Service (PDS).

NOTE

Anytime the battery terminal has been disconnected, the Parking Assist Monitor System MUST be initialized.

Warranty Information

OP CODE	DESCRIPTION	TIME	OFP	T1	T2
N/A	Not Applicable to Warranty	–	–	–	–

Initialization of Parking Assist Monitor System

Initialization Procedure

1. Start the engine.
2. Check if the Parking Assist Monitor System is operative by moving the shift lever to the "R" position.

"System is initializing." appears on the rear view monitor as shown in Figures 1 and 2.

Figure 1. Rear View (Before Initialization)

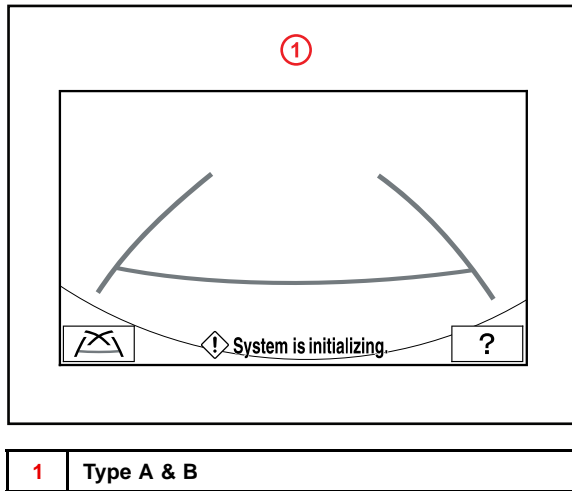
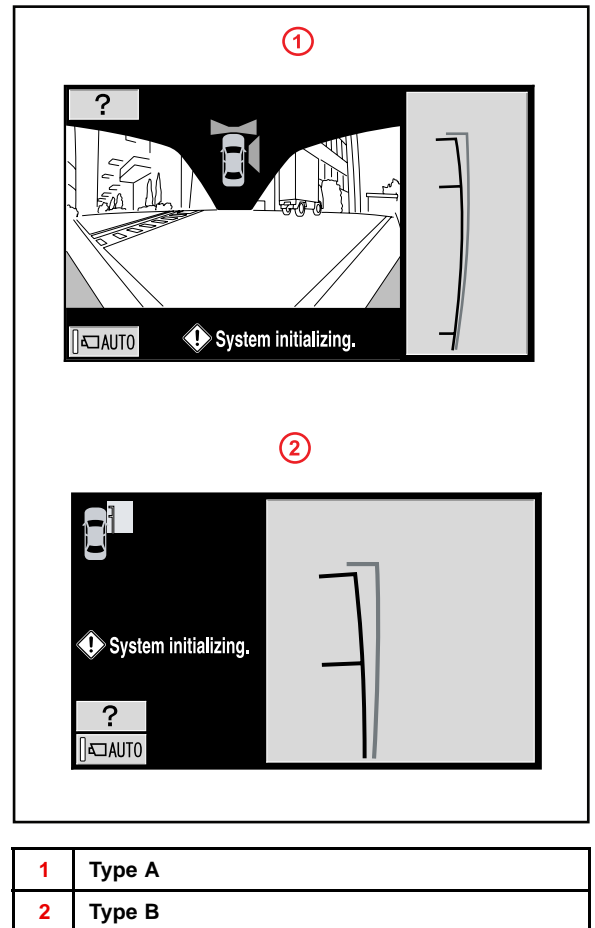

Figure 2. Side View (Before Initialization)



3. Move the shift lever to the "P" position and turn the steering wheel lock to lock.

Initialization of Parking Assist Monitor System

Initialization Procedure (Continued)

4. Move the shift lever to the "R" position.

When "Check surroundings for safety." appears on the rear view monitor as shown in Figures 3 and 4, the initialization of the Parking Assist Monitor System has been completed.

Figure 3. Rear View (After Initialization)

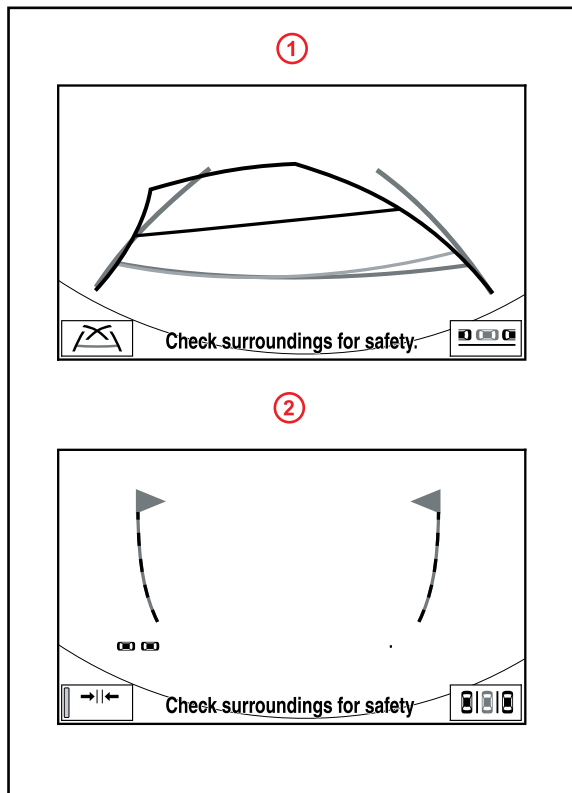

1	Type A
2	Type B

Figure 4. Side View (After Initialization)

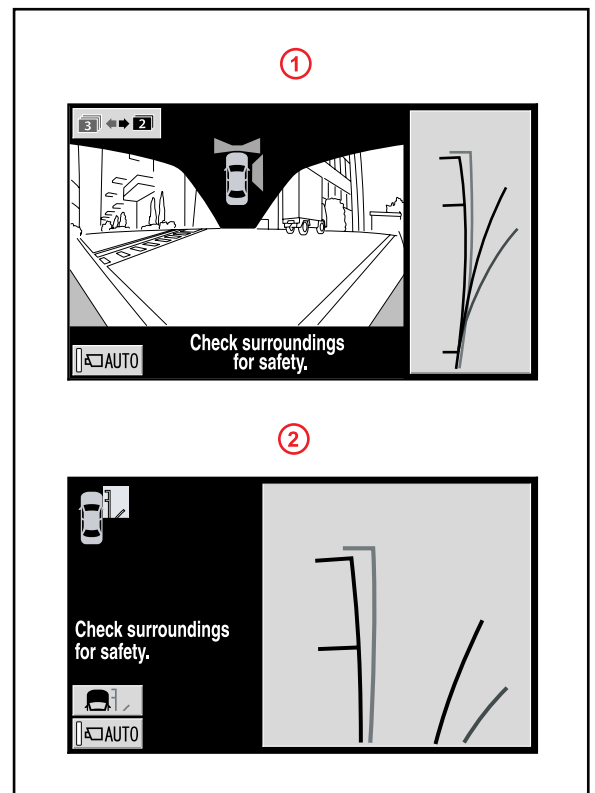

1	Type A
2	Type B