

Short Pin Installation During PDS

Service Category General

Section Pre-Delivery Service

Market USA

Lexus Supports
ASE Certification 

Applicability

YEAR(S)	MODEL(S)	ADDITIONAL INFORMATION
2015	ES300H, ES350	

Introduction

To minimize battery discharge during transportation and storage, the Short Pin has been removed at the assembly plant and temporarily stored in the engine compartment Relay Block. Reinstall the Short Pin into its original location and confirm all related Diagnostic Trouble Codes (DTCs) are cleared during Pre-Delivery Service (PDS).

Required Tools & Equipment

REQUIRED EQUIPMENT	SUPPLIER	PART NUMBER	QTY
Techstream 2.0*	ADE	TS2UNIT	1
Techstream Lite		TSLITEPDLR01	

* Essential SST.

NOTE

- Only ONE of the Techstream units listed above is required.
- Software version 9.20.022 or later is required.
- Additional Techstream units may be ordered by calling Approved Dealer Equipment (ADE) at 1-800-368-6787.

Warranty Information

OP CODE	DESCRIPTION	TIME	ONP	T1	T2
N/A	Not Applicable to Warranty	–	–	–	–

Short Pin Installation During PDS

Installation Procedure

1. Remove the Short Pin from the blank space of the Relay Block in the engine compartment and install the Short Pin in the Relay Block as shown.

Figure 1.

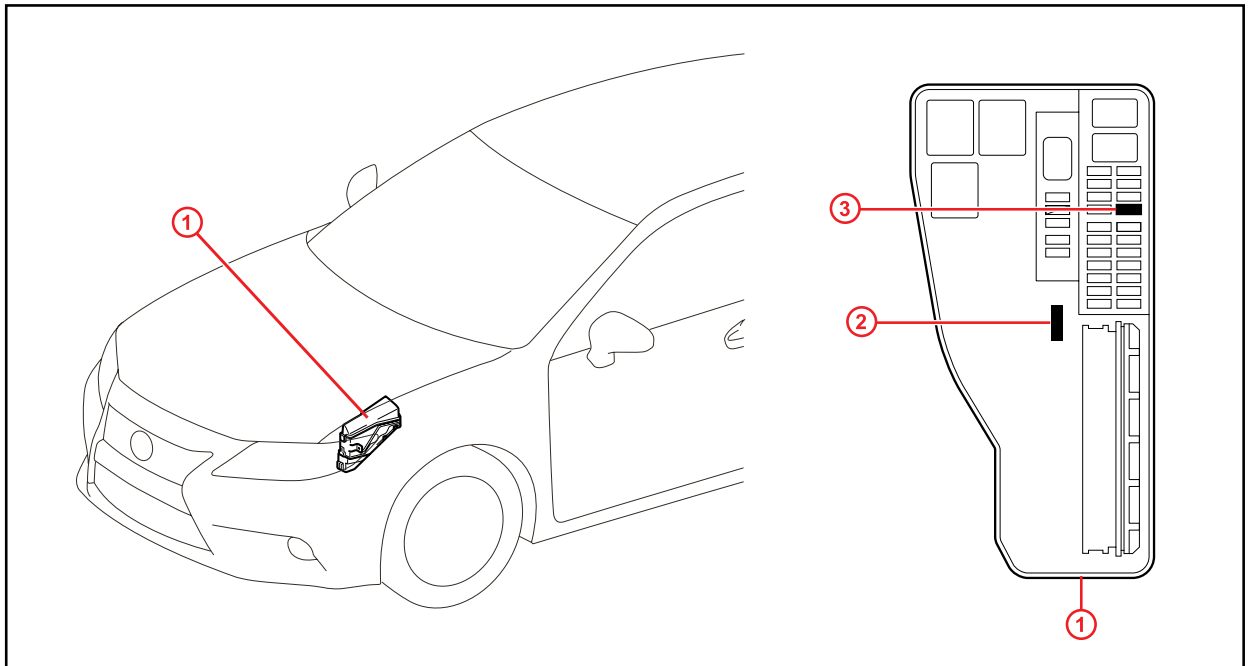

1	Relay Block
2	Remove This Short Pin

3	Install Short Pin Here (Original Location)
---	--

NOTE

- The Short Pin does NOT function as a fuse, so install it only in the position shown.
- If the vehicle is stored after PDS, disconnect the negative (-) battery terminal to prevent battery discharge. Refer to Service Bulletin No. [PG001-06](#), "Battery Maintenance for In-Stock Vehicles & Pre-Delivery."

DTC Clearing Procedure

With the Short Pin removed, the occupant classification ECU and Center Airbag Sensor Assembly (airbag ECU) may detect the interruption in battery voltage (B+) and store one or more DTCs. Clear DTCs B1650 and B1794 after installing the Short Pin.

1. Connect Techstream to the DLC3.
2. Cycle the ignition switch to the "IG-ON" position.

Short Pin Installation During PDS

DTC Clearing Procedure (Continued)

3. Using Techstream, check for any stored DTCs.

NOTE

If any DTCs other than B1650 and B1794 are found, repair the applicable system according to the Repair Manual before proceeding.

4. Erase DTCs and Freeze Frame Data.