



## 2015 PRE-DELIVERY SERVICE CHECK SHEET

BEFORE INSPECTION	OK	Adjust/Repair
01 Install DCC Fuse (see page 2) .....	<input type="checkbox"/>	<input type="checkbox"/>
02 Connect Delivery Mode Wire Harness Connectors (automatic transmission only) (see page 2) .....	<input type="checkbox"/>	<input type="checkbox"/>

FUNCTIONAL OPERATION		
<i>Apply parking brake and cycle ignition "IG-ON," place gear selector in reverse; turn on lights and rear defogger. Unlock all doors, release fuel door, release trunk hatch.</i>		
01 Check dome, courtesy, map, and sun visor lights* .....	<input type="checkbox"/>	<input type="checkbox"/>
02 Check warning/indicator lights, gauges, and horn .....	<input type="checkbox"/>	<input type="checkbox"/>
03 Check windshield wipers and washers .....	<input type="checkbox"/>	<input type="checkbox"/>
04 Check headlights, instrument lights, turn signals, dimmer switch, emergency flashers, and brake lights .....	<input type="checkbox"/>	<input type="checkbox"/>
05 Check inside/outside rear view mirror operation/adjustment .....	<input type="checkbox"/>	<input type="checkbox"/>
06 Check power outlet* and cigarette lighter .....	<input type="checkbox"/>	<input type="checkbox"/>
07 Check audio/navigation* systems, set SSP* to FR-S, and set clock .....	<input type="checkbox"/>	<input type="checkbox"/>
08 Install shift-lock override button cover .....	<input type="checkbox"/>	<input type="checkbox"/>

WALKAROUND INSPECTION		
<i>Start at driver's front door, check window and door lock operation (from master power switch, if equipped). Continue around vehicle in a counterclockwise direction checking each door and window operation, child door locks, seat belts, interior condition, all lights, luggage compartment contents. Finish by checking headlight aim and continue into UNDER HOOD checks.</i>		
01 Check Smart Key System* .....	<input type="checkbox"/>	<input type="checkbox"/>
02 Check door and door lock operation, including each wireless remote control/theft deterrent system* .....	<input type="checkbox"/>	<input type="checkbox"/>
03 Check power window operation .....	<input type="checkbox"/>	<input type="checkbox"/>
04 Check that engine starts with all keys .....	<input type="checkbox"/>	<input type="checkbox"/>
05 Check seats and seat belt operation .....	<input type="checkbox"/>	<input type="checkbox"/>
06 Check rear defogger .....	<input type="checkbox"/>	<input type="checkbox"/>
07 Check side marker, tail, backup, and license plate lights .....	<input type="checkbox"/>	<input type="checkbox"/>
08 Check rear cargo area trim appearance .....	<input type="checkbox"/>	<input type="checkbox"/>
09 Adjust compact spare tire pressure and check jack and tool installation .....	<input type="checkbox"/>	<input type="checkbox"/>
10 Check headlight aim .....	<input type="checkbox"/>	<input type="checkbox"/>

UNDER HOOD		
01 Check engine oil level .....	<input type="checkbox"/>	<input type="checkbox"/>
02 Check brake and clutch* fluid levels .....	<input type="checkbox"/>	<input type="checkbox"/>
03 Check engine coolant level .....	<input type="checkbox"/>	<input type="checkbox"/>
04 Check windshield washer fluid level .....	<input type="checkbox"/>	<input type="checkbox"/>
05 Check battery state-of-charge using Digital Battery System Analyzer (SOC Reading: _____%) .....	<input type="checkbox"/>	<input type="checkbox"/>
06 Inspect for fuel, oil, coolant, and other fluid leaks .....	<input type="checkbox"/>	<input type="checkbox"/>

UNDER VEHICLE (ON HOIST)	OK	Adjust/Repair
01 Remove disc brake anti-rust covers/anti-corrosion wheel film* .....	<input type="checkbox"/>	<input type="checkbox"/>
02 Activate the Tire Pressure Warning System (TPWS) sensors (see page 2) .....	<input type="checkbox"/>	<input type="checkbox"/>
03 Inspect tires for defects/damage .....	<input type="checkbox"/>	<input type="checkbox"/>
04 Install rubber body plugs .....	<input type="checkbox"/>	<input type="checkbox"/>
05 Remove spring spacers (Release Series 1.0 only) ....	<input type="checkbox"/>	<input type="checkbox"/>
06 Inspect for fuel, oil, coolant, and other fluid leaks .....	<input type="checkbox"/>	<input type="checkbox"/>
07 Visually check bolts and nuts on chassis and powertrain for looseness .....	<input type="checkbox"/>	<input type="checkbox"/>
08 Inspect under the vehicle for damage, rust, etc. ....	<input type="checkbox"/>	<input type="checkbox"/>

ROAD TEST		
<i>A complete road test helps assure customer satisfaction. Drive vehicle over a variety of road surfaces and driving conditions. Check for unusual noise and driving performance.</i>		
<b>Enter Odometer Reading</b>		
Reading Before Test: _____ Reading After Test: _____		
01 Check cold engine operation .....	<input type="checkbox"/>	<input type="checkbox"/>
02 Check engine operation during warm-up .....	<input type="checkbox"/>	<input type="checkbox"/>
03 Check engine at normal operating temperature .....	<input type="checkbox"/>	<input type="checkbox"/>
04 Check clutch or automatic transmission operation .....	<input type="checkbox"/>	<input type="checkbox"/>
05 Check brake and parking brake operation .....	<input type="checkbox"/>	<input type="checkbox"/>
06 Check steering operation and off-center/vehicle pull/flutter .....	<input type="checkbox"/>	<input type="checkbox"/>
07 Inspect for abnormal noise and vibration .....	<input type="checkbox"/>	<input type="checkbox"/>
08 Inspect for squeaks and rattles .....	<input type="checkbox"/>	<input type="checkbox"/>
09 Check heater and A/C operation .....	<input type="checkbox"/>	<input type="checkbox"/>
10 Check speedometer operation .....	<input type="checkbox"/>	<input type="checkbox"/>
11 Check cruise control operation .....	<input type="checkbox"/>	<input type="checkbox"/>

FINAL INSPECTION AND CLEANING		
01 Remove interior protective covers, unnecessary labels, tags, etc. (Remove protective covers just before delivery to customer) .....	<input type="checkbox"/>	<input type="checkbox"/>
02 Verify floor mat application and install using retaining clips* .....	<input type="checkbox"/>	<input type="checkbox"/>
03 Visually inspect all interior parts for installation, damage, fit, dirt, etc. ....	<input type="checkbox"/>	<input type="checkbox"/>
04 Remove Rappgard™ and clear protective bumper film* ...	<input type="checkbox"/>	<input type="checkbox"/>
05 Wash and clean vehicle .....	<input type="checkbox"/>	<input type="checkbox"/>
06 Inspect paint finish for scratches, chips, rust, dents, damage, etc. ....	<input type="checkbox"/>	<input type="checkbox"/>
07 Inspect exterior body parts for proper installation, damage, rust, etc. ....	<input type="checkbox"/>	<input type="checkbox"/>
08 Place Owner's Guide and first aid kit portfolio* in glove box .....	<input type="checkbox"/>	<input type="checkbox"/>
09 Place oil change sticker on inside of windshield, top left corner .....	<input type="checkbox"/>	<input type="checkbox"/>
10 Perform Techstream Health Check .....	<input type="checkbox"/>	<input type="checkbox"/>
11 Install front license plate and mounting bracket* (see page 2) .....	<input type="checkbox"/>	<input type="checkbox"/>
<b>* Inspect or install when equipped/required.</b>		

Completion and retention of this form is required to comply with Toyota's Warranty Policy.

TECHNICIAN'S SIGNATURE \_\_\_\_\_

SERVICE MANAGER'S SIGNATURE \_\_\_\_\_

NAME (PLEASE PRINT) \_\_\_\_\_

NAME (PLEASE PRINT) \_\_\_\_\_

Date \_\_\_\_\_

Dealer Name \_\_\_\_\_

Dealer Code \_\_\_\_\_

Vehicle Identification Number (Sticker) \_\_\_\_\_

**We hereby certify that all items on this form have been checked and corrected for proper operation as required.**

## DCC FUSE INSTALLATION

To minimize battery discharge the DCC fuse has been removed and is stored in the engine compartment Relay Block. Install the DCC fuse during PDS.

### NOTE

Failure to install the DCC fuse may cause the Check Engine Light (MIL) to flash with no engine misfires or DTCs stored and may cause the radiator fans to cycle on and off rapidly.

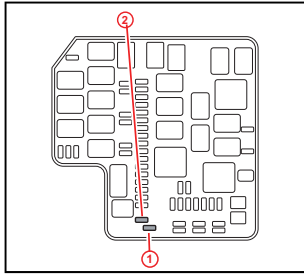

- 1 Remove This DCC Fuse
- 2 Install DCC Fuse Here

## DELIVERY MODE WIRE HARNESS CONNECTORS

(Automatic Transmission ONLY)

The delivery mode connectors for key interlock have been disconnected at the assembly plant to prevent damage to automatic transmission during rail transport.

The disconnected delivery mode connectors must be connected during PDS.

1. From the driver side cowl trim, remove the 2 disconnected connectors.
2. Connect the 2 connector ends.
3. Place connector inside cowl trim area.
4. Confirm transmission will not shift from P with ignition OFF.
5. Confirm the ignition switch cannot be turned from ACC to LOCK or that the key cannot be removed from the key cylinder when the shift lever is NOT in P.

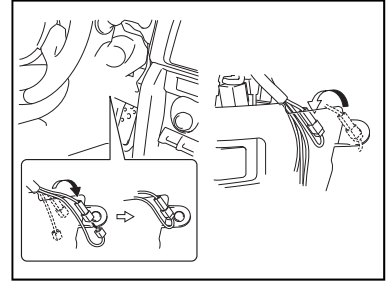

## TPWS ACTIVATION

### Activation Procedure

1. Connect Techstream.
2. Cycle the IG switch to the "IG-ON" position and check that the Low Tire Pressure Warning Light blinks for 1 minute and then remains illuminated.
3. Press or remove the valve core to reduce the tire inflation pressure rapidly by 6 psi (0.4 kgf/cm<sup>2</sup>, 40 kPa), or more, within 30 seconds.
4. Check that the Low Tire Pressure Warning Light goes OFF after all the TPWS sensors are activated.

### NOTE

To adjust the tire pressure correctly when the outside temperature is significantly colder than shop temperature, perform a Health Check using Techstream and select the "Compensation Tire Pressure" checkbox. Compensation pressures will be displayed on the Health Check results screen. Adjust the tire pressure when the tires are cold.

5. Using Techstream, check for DTCs (C2111-C2114). If DTCs C2111-C2114 are stored, repeat step 3.
6. System initialization is NOT available or required.

## FRONT LICENSE PLATE AND MOUNTING BRACKET INSTALLATION\*

For states that require a front license plate, please install per this procedure. The mounting bracket, self-tapping screws, flange bolts, J-nuts, and non-corroding bolts are stored in the luggage compartment.

### Installation Procedure

1. Align holes "A" of the mounting bracket and the dimples on the front intake cover. Temporarily install the 2 self-tapping screws.
2. Mark the location of holes "B" on the front bumper cover.

### NOTE

Holes "A" and "B" are used for the installation of the mounting bracket to the bumper cover.

3. Remove the license plate mounting bracket.
4. Mark the Mark "C" locations on the front bumper cover as shown in the illustration.
5. Drill 2 relief holes with a diameter of 10 mm (0.39 in.) at Mark "B" on the front bumper cover.
6. Drill 6 relief holes with a diameter of 22 mm (0.87 in.) at Mark "C" on the front bumper cover as shown in the illustration.

### NOTE

Holes "C" are used to install J-nuts to the front bumper cover.

7. Install the 2 J-nuts to the front bumper cover through holes "C".
8. Align holes "B" of the mounting bracket and the J-nuts on the front bumper cover. Temporarily install the 2 flange bolts.
9. Align holes "A" of the mounting bracket and the dimples on the front intake cover. Temporarily install the 2 self-tapping screws.
10. Tighten the 2 flange bolts and tapping screws equally so that there is no clearance between the license plate mounting bracket and the front bumper cover.
11. Install the front license plate to the mounting bracket using the 2 non-corroding bolts.

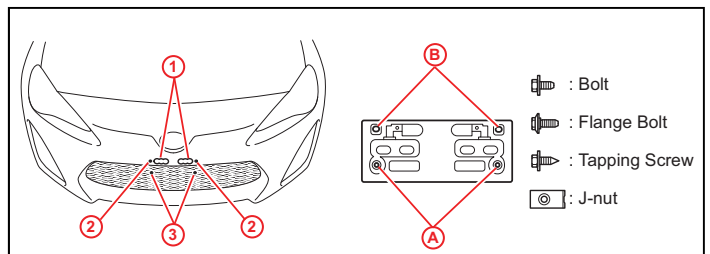

- 1 Mark "C"
- 2 Mark "B"
- 3 Dimples
- A Holes "A"
- B Holes "B"

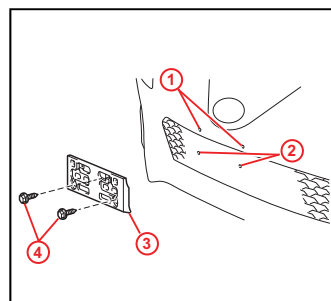

- 1 Mark "B"
- 2 Dimples
- 3 License Plate Mounting Bracket
- 4 Tapping Screw

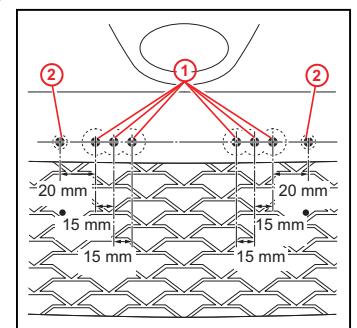

- 1 Mark "C"
- 2 Mark "B"

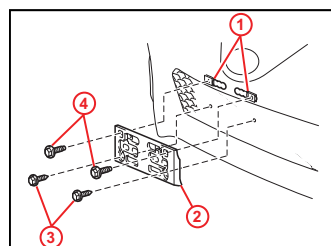

- 1 J-nut
- 2 License Plate Mounting Bracket
- 3 Tapping Screw
- 4 Flange Bolt