

# Spring Spacer Removal During PDS

**Service Category** General

**Section** Pre-Delivery Service

**Market** USA

Scion Supports ASE Certification 

## Applicability

YEAR(S)	MODEL(S)	ADDITIONAL INFORMATION
2015	FR-S	

## Introduction

The 2015 model year FR-S has a new accessory package known as Release Series 1.0 that includes a suspension kit. To minimize vehicle damage during transportation, spacers have been installed on the front shock absorber piston shafts to hold the front of the vehicle up approximately two (2) inches over normal ride height. These spacers must be removed during Pre-Delivery Service (PDS).

The Release Series 1.0 package can be identified by a number of ways, two of which are:

1. “Yuzu” vehicle paint.
2. Embossed TRD logo in the rear fascia.

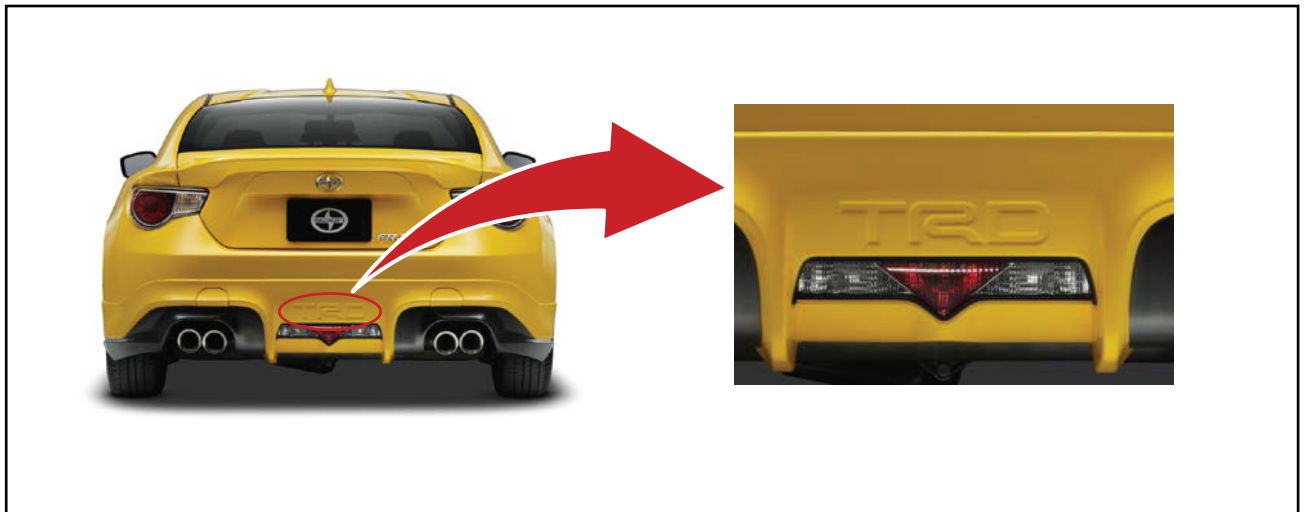

## Warranty Information

OP CODE	DESCRIPTION	TIME	ONP	T1	T2
N/A	Not Applicable to Warranty	–	–	–	–

## Spring Spacer Removal During PDS

### Repair Procedure

1. Raise the vehicle on a hoist.
2. Lift corrugated dust boot on the front shock assembly.

Figure 1.

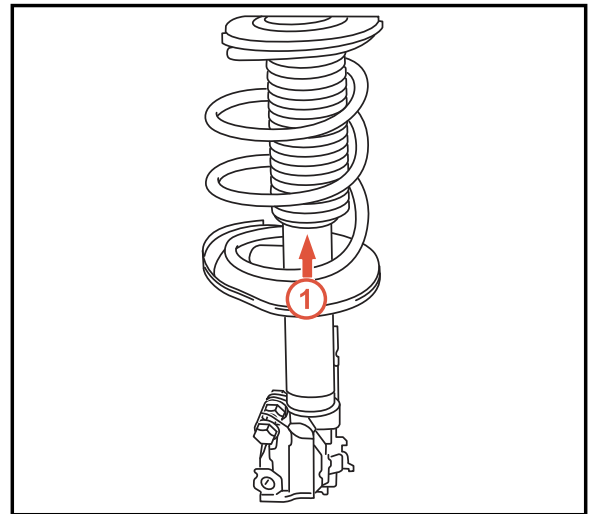

1 Dust Boot

3. Clip the nylon tie from the red spring spacer.
4. Remove the red spring spacers and nylon ties from the shock absorber and pull through the open spring coil.

**NOTE**

- There are two spacers on each front shock absorber.
- Make sure the dust boot is properly in place when finished.

Figure 2.

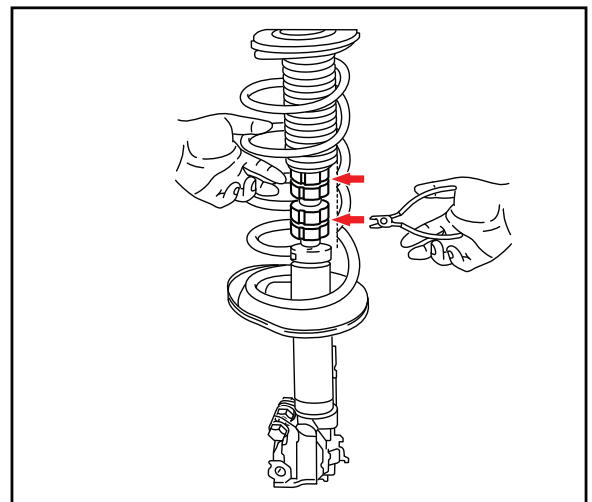

5. Repeat steps 2 - 4 for other front shock absorber.