

D/C Cut Fuse Installation During PDS

Service Category General

Section Pre-Delivery Service

Market USA

Lexus Supports
ASE Certification 

Applicability

| YEAR(S) | MODEL(S) | ADDITIONAL INFORMATION |
|---------|----------------|------------------------|
| 2015 | NX200T, NX300H | |

Introduction

To minimize battery discharge during transportation and storage, the D/C Cut fuse (20A) has been removed at the assembly plant, and temporarily stored in the blank space of the relay block in the engine compartment.

During Pre-Delivery Service (PDS), reinstall the D/C Cut fuse into its original location.

Warranty Information

| OP CODE | DESCRIPTION | TIME | OFP | T1 | T2 |
|---------|----------------------------|------|-----|----|----|
| N/A | Not Applicable to Warranty | – | – | – | – |

D/C Cut Fuse Installation During PDS

Installation Procedure

1. Remove the D/C Cut fuse (20A) from the blank space of the relay block in the engine compartment and install it in the location shown in Figure 1 during Pre-Delivery Service (PDS).

Figure 1.

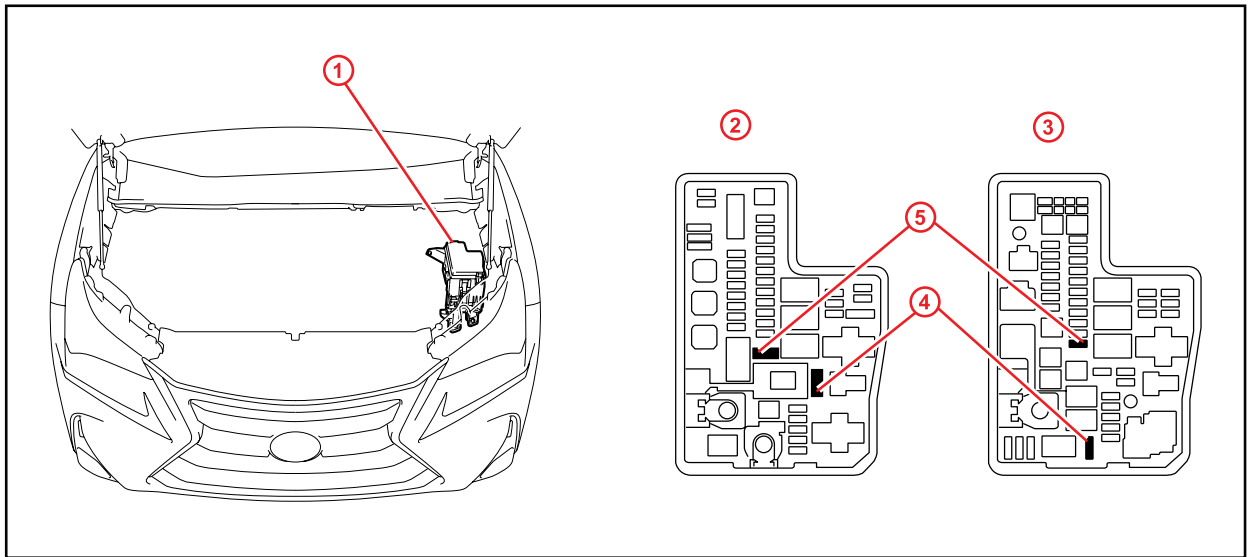

| | |
|---|-----------------------|
| 1 | Relay Block |
| 2 | For Hybrid Vehicles |
| 3 | For Gasoline Vehicles |

| | |
|---|---|
| 4 | Remove this D/C Cut Fuse (20A) |
| 5 | Install D/C Cut Fuse (20A) Here (Original Location) |

NOTE

While the vehicle is stored at the dealership, disconnect the negative (-) battery terminal to prevent battery discharge. Refer to Service Bulletin No. [PG001-06](#), "Battery Maintenance for In-Stock Vehicles & Pre-Delivery," for battery maintenance information.