

TECHNICAL BULLETIN  
LTB00679NAS1  
07 AUG 2014



© Jaguar Land Rover North America, LLC

NOTE: The information in Technical Bulletins is intended for use by trained, professional Technicians with the knowledge, tools, and equipment required to do the job properly and safely. It informs these Technicians of conditions that may occur on some vehicles, or provides information that could assist in proper vehicle service. The procedures should not be performed by 'do-it-yourselfers'. If you are not a Retailer, do not assume that a condition described affects your vehicle. Contact an authorized Land Rover service facility to determine whether this bulletin applies to a specific vehicle.

**SECTION: 415-01**

Loss Of Global Positioning System (GPS) Signal

**AFFECTED VEHICLE RANGE:**

**Range Rover Sport (LW)**

**Model Year:** 2014

**VIN:** EA350500-EA360010

**Range Rover (LG)**

**Model Year:** 2013-2014

**VIN:** DA158800-EA160031

**MARKETS:**

NAS

**CONDITION SUMMARY:**

**Situation:** The Global Positioning System (GPS) may be inactive with a red 'slash' displayed across the GPS icon on the Touch Screen.

**Cause:** This may be caused by GPS antenna circuit board delamination.

**Action:** Should a customer express this concern, follow the Service Instruction outlined below.

**PARTS:**

LR059752

Roof pod

Quantity: 1

**TOOLS:**

Refer to Workshop Manual for any required special tools.

**WARRANTY:**

 **NOTE: Repair procedures are under constant review, and therefore times are subject to change; those quoted here must be taken as guidance only. Always refer to TOPIx to obtain the latest repair time.**

 **NOTE: DDW requires the use of causal part numbers. Labor only claims must show the causal part number with a quantity of zero.**

DESCRIPTION	SRO	TIME (HOURS)	CONDITION CODE	CAUSAL PART
Roof pod - Renew - Range Rover Sport (L494)	<b>86.53.05</b>	1.9	42	XUI000120
Roof pod - Renew - Range Rover (L405)	<b>86.53.05</b>	1.7	42	XUI000120

 **NOTE: Normal Warranty policies and procedures apply.**

**SERVICE INSTRUCTION:**

 **NOTE: Removal steps in this procedure may contain installation details.**

-  **NOTE: This procedure must be carried out on both sides.**

Remove the Sun Visor (see TOPIx Workshop Manual, section 501-05).

-  **NOTE: This procedure must be carried out on both sides.**

Remove both A-pillar trim panels (see TOPIx Workshop Manual, section 501-05).

-  **NOTE: This procedure must be carried out on both sides.**

Remove both B-pillar trim panels (see TOPIx Workshop Manual, section 501-05).

4.  **NOTE: This procedure must be carried out on both sides.**

Remove both C-pillar trim panels (see TOPIx Workshop Manual, section 501-05).

5.  **NOTE: This procedure must be carried out on both sides.**

Remove both D-pillar trim panels (see TOPIx Workshop Manual, section 501-05).

6.  **NOTE: This procedure must be carried out on both sides.**

Remove the overhead console (see TOPIx Workshop Manual, section 501-12).

7.  **NOTE: Note the orientation of the seal prior to detaching.**

Reposition the tailgate seal.

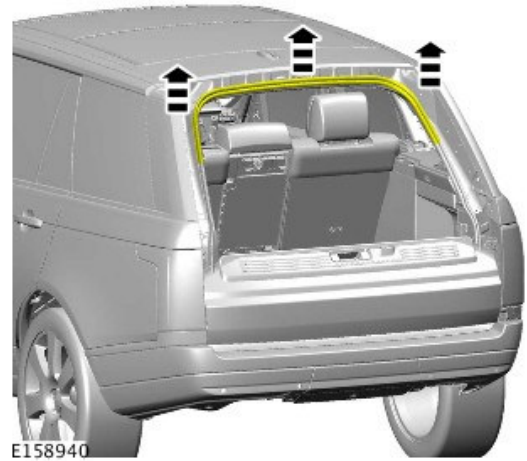

E158940

8.  **NOTE: This procedure must be carried out on both sides.**

Remove the roof handle and position the front door seal to one side.

- Torque: 6 Nm.

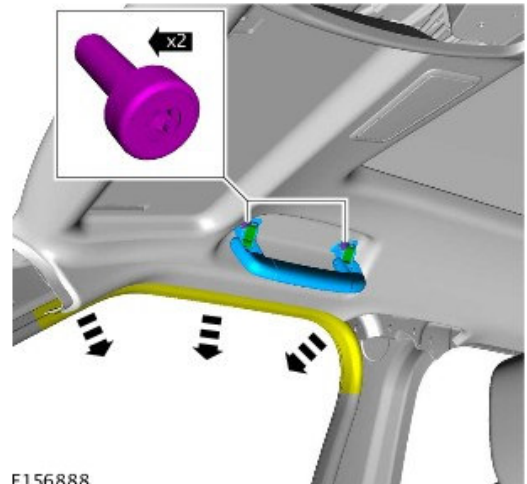

E156888

9.  **NOTE: This procedure must be carried out on both sides.**

Remove the roof handle and position the rear door seal to one side.

- Torque: 6 Nm.

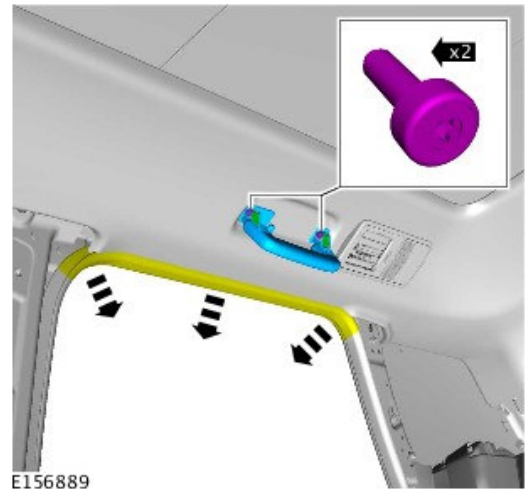

10.  **NOTE: This procedure must be carried out on both sides.**

Remove the interior lamp cover.

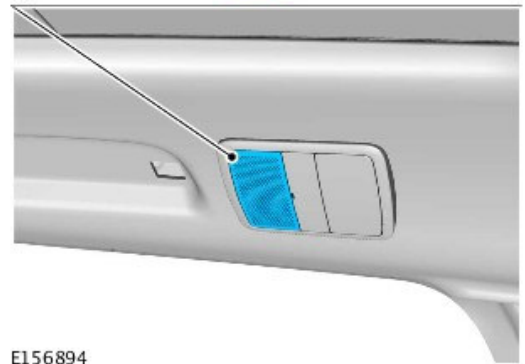

11.  **NOTE: This procedure must be carried out on both sides.**

Remove the interior lamp cover retaining bolt.

- Torque: 6 Nm.

12.  **NOTE: This procedure must be carried out on both sides If equipped.**

Remove the roof air vents.

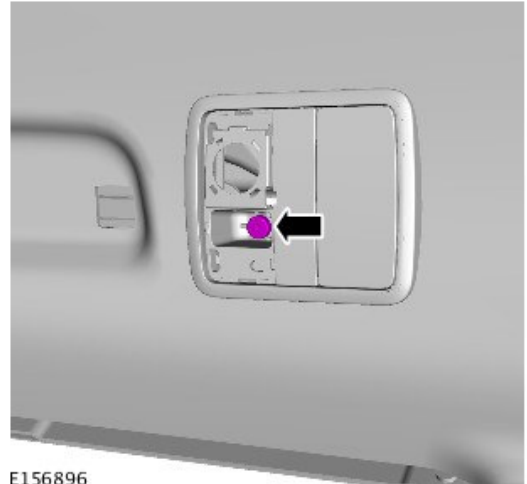

13.  **NOTE: This procedure must be carried out on both sides If equipped.**

Remove the roof air vent fixings.

- Torque: 6 Nm.

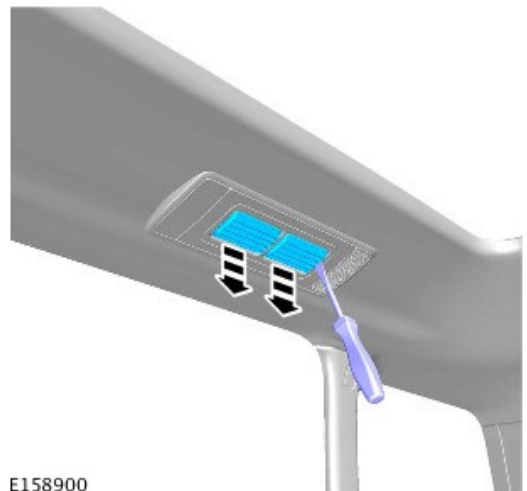

14.  **CAUTION:**  
Take extra care not to damage the component.



 **NOTE:**  
This procedure must be carried out on both sides if equipped.

Detach the headliner retainers as shown.

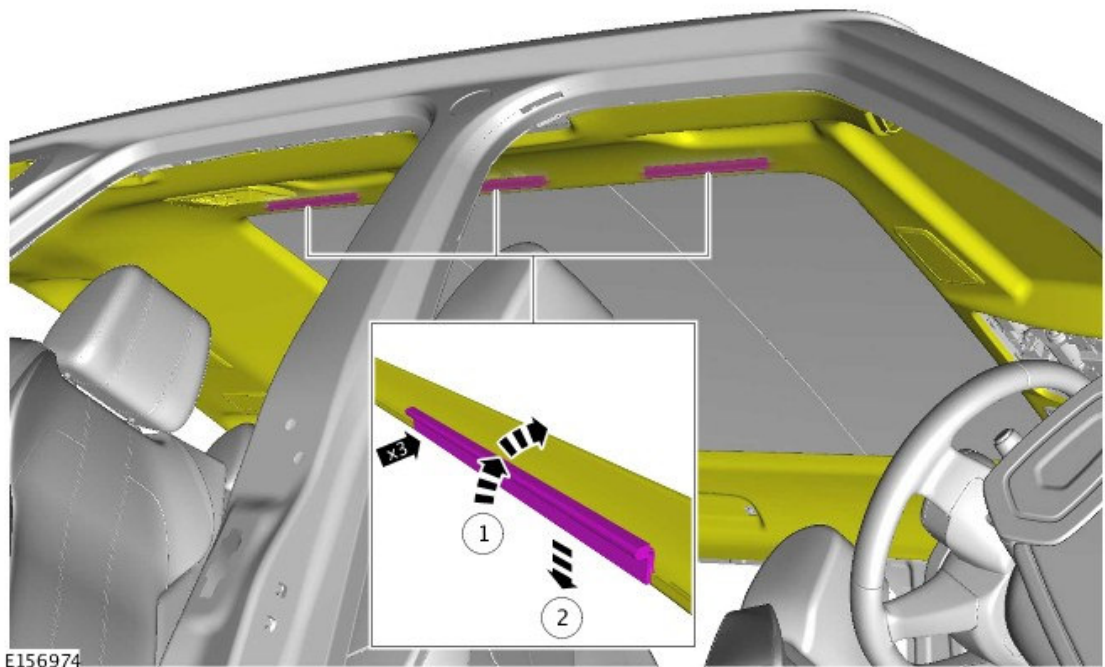

15.  **CAUTION:** Take extra care not to damage the component.

 **CAUTION:** Using a suitable plastic trim tool, release the magnetic fixings.

 **CAUTION:** Make sure that there is at least 50mm clearance between the magnetic fixings and the headliner during the removal procedure. The fixings will engage if too close to each other.

Remove the headliner retaining clips as shown.

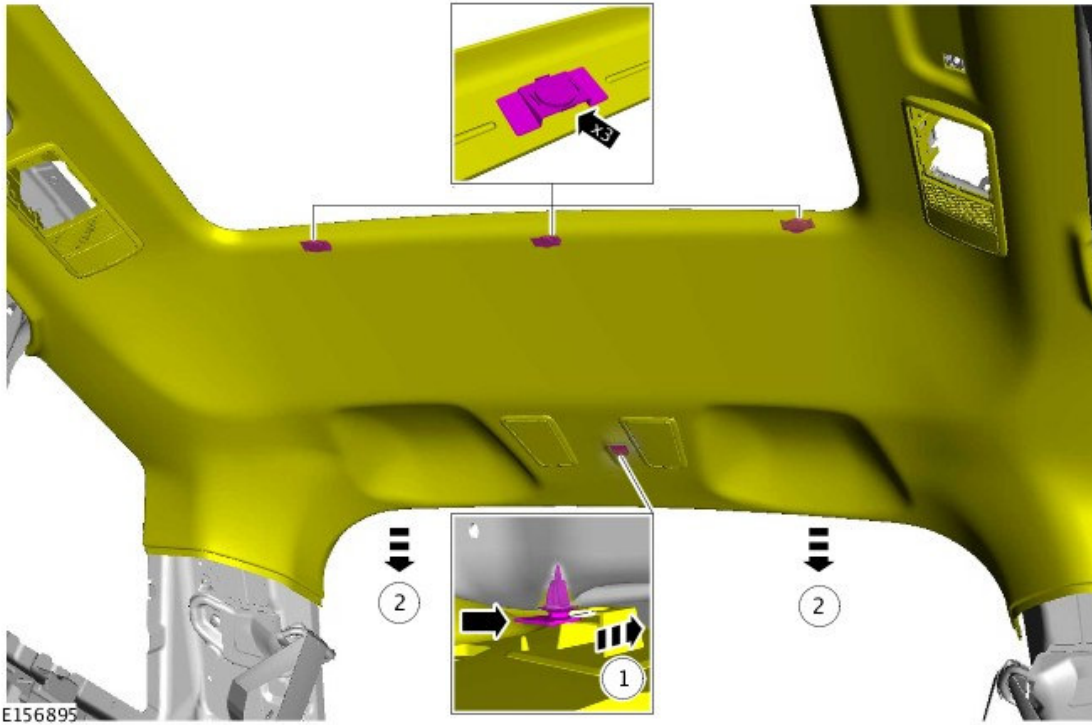

16. Remove the headliner retaining clips as shown.

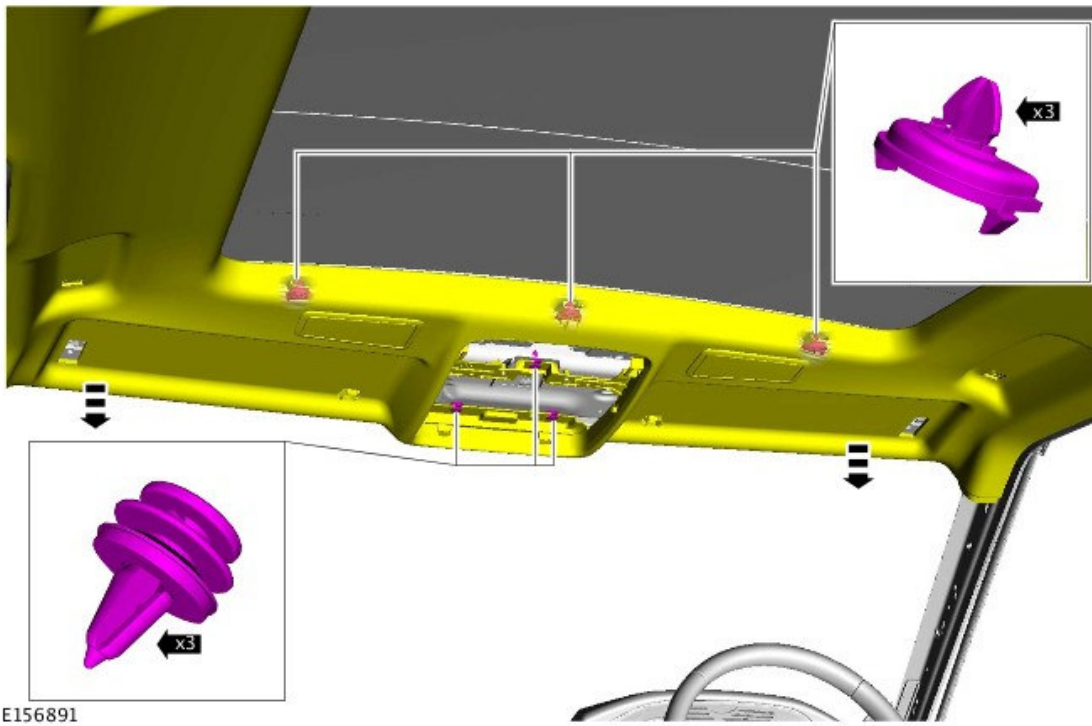

17.  **CAUTION: Take extra care not to damage the component.**

Lower the headliner.



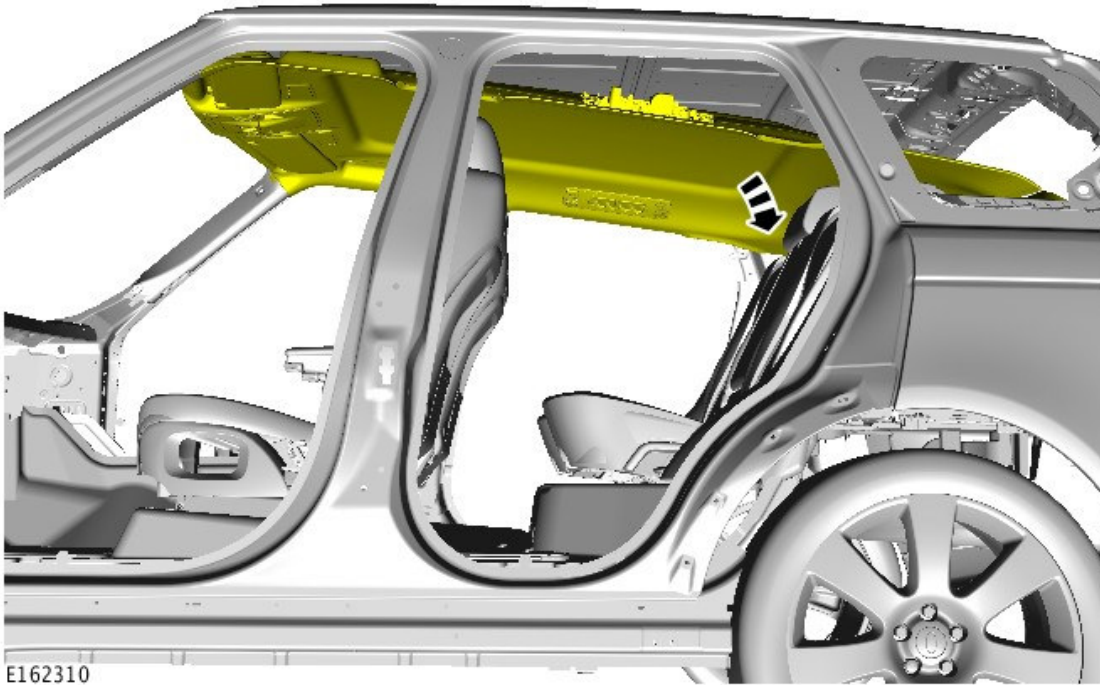

**18.** Remove the roof pod retaining nuts.



**19.** Disconnect the roof pod electrical connectors.

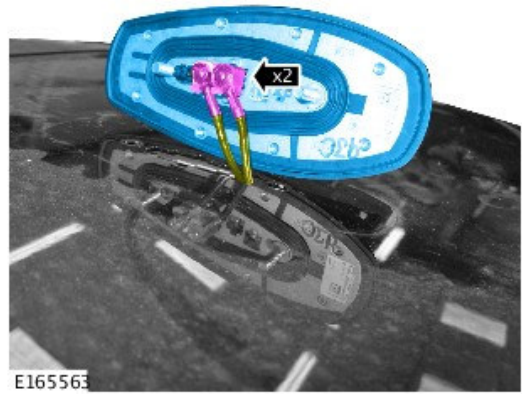

**20.** Remove and discard the roof pod.

**21.** Reverse steps 1-20 to install the new roof pod.