

TECHNICAL BULLETIN
LTB00557NAS2
23 JAN 2014



© Jaguar Land Rover North America, LLC

NOTE: The information in Technical Bulletins is intended for use by trained, professional Technicians with the knowledge, tools, and equipment required to do the job properly and safely. It informs these Technicians of conditions that may occur on some vehicles, or provides information that could assist in proper vehicle service. The procedures should not be performed by 'do-it-yourselfers'. If you are not a Retailer, do not assume that a condition described affects your vehicle. Contact an authorized Land Rover service facility to determine whether this bulletin applies to a specific vehicle.

This reissue replaces all previous versions. Please destroy all previous versions. Only refer to the electronic version of this Technical Bulletin in TOPIx.

Changes are highlighted in gray

SECTION: 204-00

Knock Sound From Front Suspension

AFFECTED VEHICLE RANGE:

Range Rover (LG)

Model Year: 2013 Onwards

VIN: DA000083 Onwards

MARKETS:

NAS

CONDITION SUMMARY:

Situation: A knock sound from the front suspension may be heard inside the vehicle when traveling over an uneven road surface. The sound may be noticeable, when one of the front wheels travels over a uneven surface while the opposite front wheel remains on a smooth surface.

Cause: This may be caused by the operation of the Dynamic Response system actuators.

Action: Should a customer express this concern, follow the Diagnostic Procedure outlined below.

PARTS:



NOTE: If required, an allowance of £35.00 (approximately \$53.65 US) for the Dynamic Response system fluid (Texaco cold climate fluid PSF14315 [33270]) and Loctite 243 has been provided and should be claimed using code 'ZZZ001'.

LR052058	Front Stabilizer Actuator (if required)	Quantity: 1
LR050753	Bolt (M12x55mm) (if required)	Quantity: 4
LR045743	Bolt (M14x55mm) (if required)	Quantity: 2
LR045788	M12 steel Repair Insert (if required)	Quantity: 4
LR043320	M14 Steel Repair Insert (if required)	Quantity: 2
RVW500010	O-Ring Seal (if required)	Quantity: 2
BTR6506	Insulation pad (if required)	Quantity: 1
QYG500090	Bolt - Steering column (M8x30mm) (if required)	Quantity: 1
LR054870	O-ring seal - Air conditioning pipe (if required)	Quantity: 1

TOOLS:

Refer to Workshop Manual for any required special tools.

WARRANTY:



NOTE: Repair procedures are under constant review, and therefore times are subject to change; those quoted here must be taken as guidance only. Always refer to TOPIx to obtain the latest repair time.



NOTE: DDW requires the use of causal part numbers. Labor only claims must show the causal part number with a quantity of zero.

DESCRIPTION	SRO	TIME (HOURS)	CONDITION CODE	CAUSAL PART
Carry out suspension diagnostics	05.11.10	1.0	42	LR046089
Actuator - Renew	60.60.50	1.60	42	LR046089
Fit steel inserts to subframe	60.35.74	2.30	42	LR046089
Strut brace bars - Remove	05.10.40	0.40	42	LR046089



NOTE: Normal Warranty policies and procedures apply.

DIAGNOSTIC PROCEDURE:

BASIC DIAGNOSTIC PROCESS:



- NOTE:** Use customer supplied occurrence information (speed/road surface/symptom) to understand what is the most probable root cause of the noises observed.

SYMPTOM: Single 'knock' OR a series of isolated 'knocks':

- **Drive Cycle / Conditions:** Single-wheel and dual-wheel inputs from speed bumps /damaged road surfaces or similar while traveling ONLY in a forward direction at speeds of up to 25mph (40kmh).

- **Action:** Perform SERVICE INSTRUCTION 1.



E162272

2. SYMPTOM: 'Knock' noise:

- **Drive Cycle / Conditions:** Noise occurs during single-wheel inputs (one side only) at speeds up to 12mph (20kmh) when traveling in both a forward

AND reverse direction. Noise can also be heard during dual-wheel input but to a lesser extent. Test both sides of the vehicle independently.

- **Action:** Refer to Technical Bulletin LTB00604NAS, Front Air Spring / Damper Hydraulic Fluid Leak.

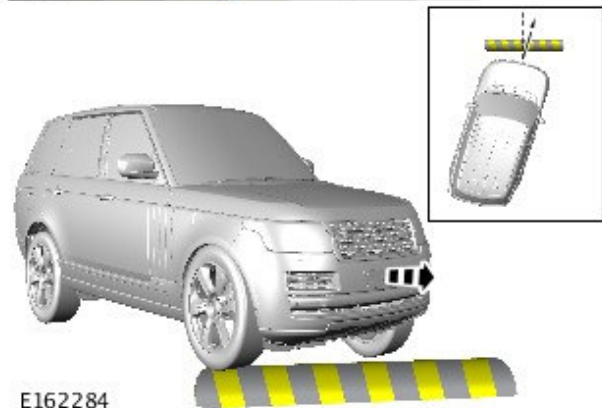

3. SYMPTOM: 'Click' noise:

- **Drive Cycle / Conditions:** 'Click' noise occurs during harsh cornering, rapid acceleration, and/or abrupt braking.
- **Action:** Refer to Technical Bulletin LTB00618NAS, 'Click' / 'Rattle' Noise From Engine Compartment When Driving.
 - If the issue is not rectified after performing the Service Instruction in this bulletin, remedial work may be required to the steering rack. Before contacting the Technical HelpLine, raise a Technical Assistance (TA) request, detailing the following: customer symptoms, road surfaces, and road speeds that create the noise. After submitting the TA request, the Technical HelpLine will advise the remedial actions required.

4. SYMPTOM: 'Rattle' noise:

- **Drive Cycle / Conditions:** Noise occurs while traveling at speeds up to 20mph (32kmh) over road surfaces shown.
- **Action:** Refer to Technical Bulletin LTB00618NAS, 'Click' / 'Rattle' Noise From Engine Compartment When Driving.
 - If the issue is not rectified after performing the Service Instruction in this bulletin, remedial work may be required to the

steering rack. Before contacting the Technical HelpLine, raise a Technical Assistance (TA) request, detailing the following: customer symptoms, road surfaces, and road speeds that create the noise. After submitting the TA request, the Technical Helpline will advise the remedial actions required.



E162256

5. SYMPTOM: 'Thud' noise:

- **Drive Cycle / Conditions:** Noise occurs while braking abruptly at low vehicle speeds.
- **Action:** Refer to Technical Bulletin LTB00573NAS, 'Thud' / 'Thump' Noise From Front Suspension On Brake Application .

SERVICE INSTRUCTION:

1.  **NOTE: This Technical Bulletin is written in a specific order where the most likely causes of this issue are dealt with first. The most likely causes will also give the biggest benefit if addressed. It is therefore imperative that the steps are followed in order.**

 **NOTE: Refer to TOPIx for all torques not explicitly specified in this document.**

 **NOTE: Replacement of any suspension component which affects suspension geometry must be followed by conducting a four-wheel alignment check following the procedure highlighted in the vehicle Workshop Manual.**

 **NOTE: Vehicle Testing: It is important to identify a test route that highlights the customer concern of suspension knock and re-test the vehicle over the same test route when identified in the following procedure. The test route should include roads that have a uneven road surface or drain covers that allow single wheel inputs. The vehicle speed that highlights the issue should be noted during the initial appraisal of the customer concern and then replicated on subsequent test drives.**

 **NOTE: Typically noise from the Dynamic Response System can be observed at low vehicle speeds (10–25mph / 16–40 km/h). Some occurrences of hydraulic knock should be expected. Only excessive /**

abnormal knocking noise indicates a concern.

Front Suspension Knock Diagnostic Test: vehicles fitted with the Dynamic Response System are expected to exhibit a low level of hydraulic knock from the system during normal operation as the input forces are reacted by the Dynamic Response System. Where there is a customer complaint of excessive / abnormal knocking noise, the following steps should be taken.

- Check and rectify basic faults before beginning diagnostic routines.
- Verify the customer concern.
- Visually inspect for obvious signs of mechanical damage.
- Ensure all tire pressures are set according to the tire label in the driver's door opening.
- It is important to identify a test route that highlights the customer concern of suspension knock and re-test the vehicle over the same test route when identified in the following procedure. The test route should include roads that have a broken road surface or drain covers that provide numerous single wheel inputs. The vehicle speed that highlights the issue should be noted during the initial appraisal of the customer concern and then replicated on subsequent test drives.

2.  **NOTE: Disconnecting the Dynamic Response System fuse is not recommended to help in diagnosing front suspension knock as it will change the forcing into the suspension.**

Front Suspension Knock Diagnostic Test (refer to step 1)

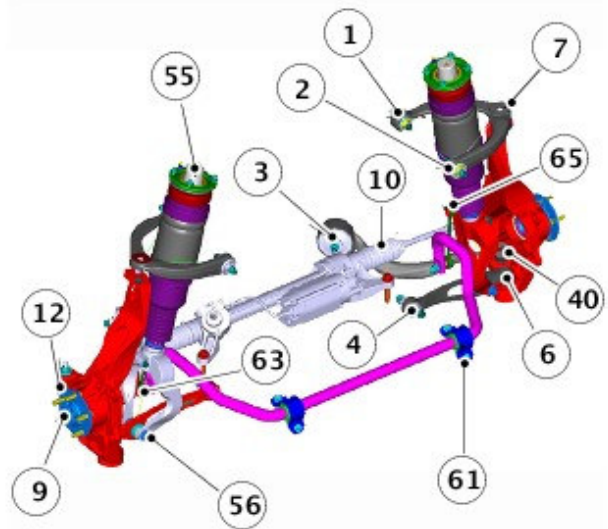

E156340

3. Disconnect electrical connectors from front Adaptive Damping System shock absorbers.

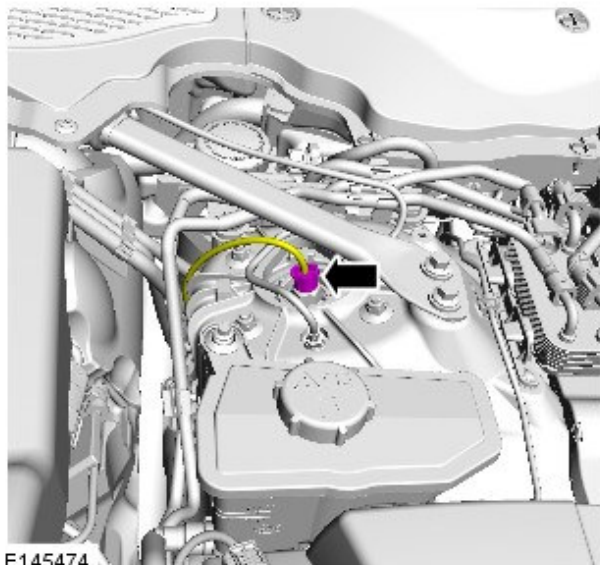

E145474

4. Carry out road test.

- If the noise is still present, refer to the Basic Diagnosis table above as the noise is not likely to be related to the Dynamic Response system.
- If the noise is not present, continue to the next step.

5. Renew the stabilizer drop link if abnormal play is found.

6. Carry out road test: if the concern is rectified, return the vehicle to the customer. If not, then continue to the next step.

- If the issue is not still present, return the vehicle to the customer.
- If the issue is still present, continue to the next step.

7. Does the roll bar arm have greater than +/- 10mm of play?

- If **YES**, perform a system bleed.
 - Initially only bleed the front Actuator as detailed in TOPIX Workshop Manual section 204-06: Active Stabilization System Bleeding.
- If **NO**, continue to the next step.

8.  **NOTE: Minimum Torque: 190Nm (refer to table 1).**

P3 Lower Control Arm to Frame

- If the measured torque is less than the minimum residual torque shown, the fixing should be replaced with new and torque with reference to TOPIX Workshop Manual section 204-01: Front Suspension.

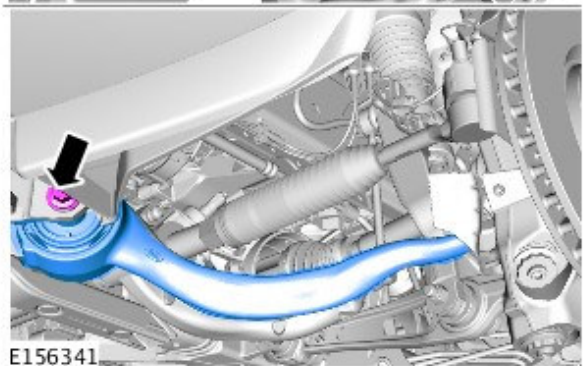
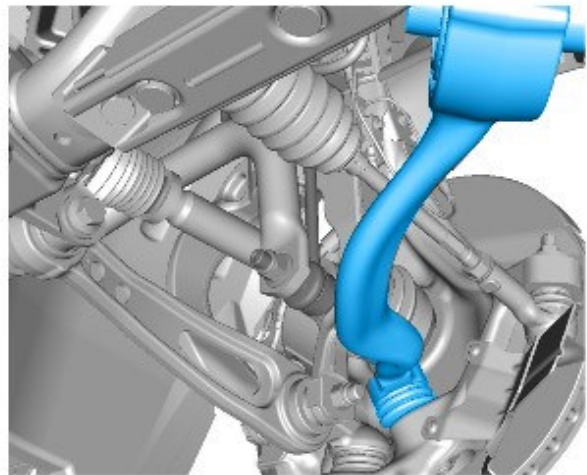

9.  **NOTE: Minimum Torque: 190Nm (refer to table 1).**

P4 Lower Control Arm to Frame

- If the measured torque is less than the minimum residual torque shown, the fixing should be replaced with new and torque with reference to TOPIX Workshop Manual section 204-01: Front Suspension.

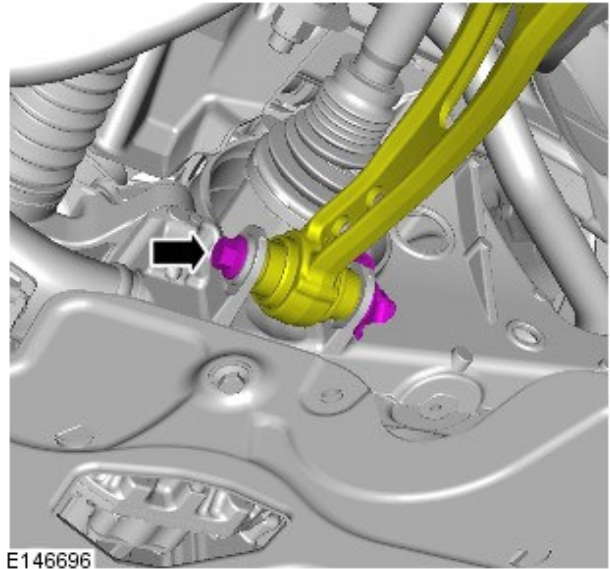

10.  **NOTE: Minimum Torque: 273Nm (refer to table 1).**

P6 Lower Ball Joint Knuckle (Lower Arm Rear)

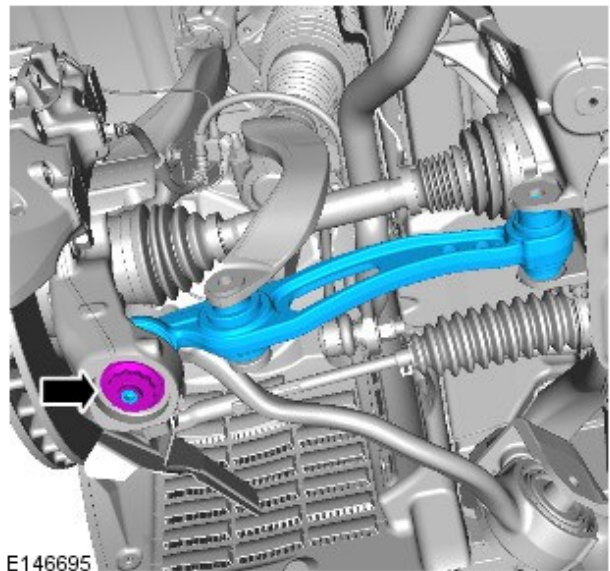

11.  **NOTE: Minimum Torque: 60Nm (refer to table 1).**

P7 Upper Control Arm to Knuckle

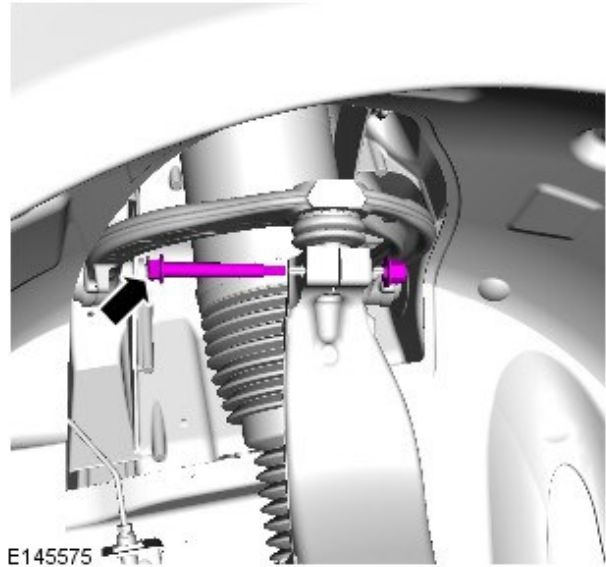

12.  **NOTE: Minimum Torque: 273Nm (refer to table 1).**

P40 Lower Ball Joint Knuckle (Lower Arm Front)



13.  **NOTE: Minimum Torque: 210Nm (refer to table 1).**

P56 Adaptive Shock Absorber Yoke to Lower Control Arm.

- If the measured torque is less than the minimum residual torque shown, the fixing should be replaced with new and torque with reference to TOPIX Workshop Manual section 204-01: Front Suspension.

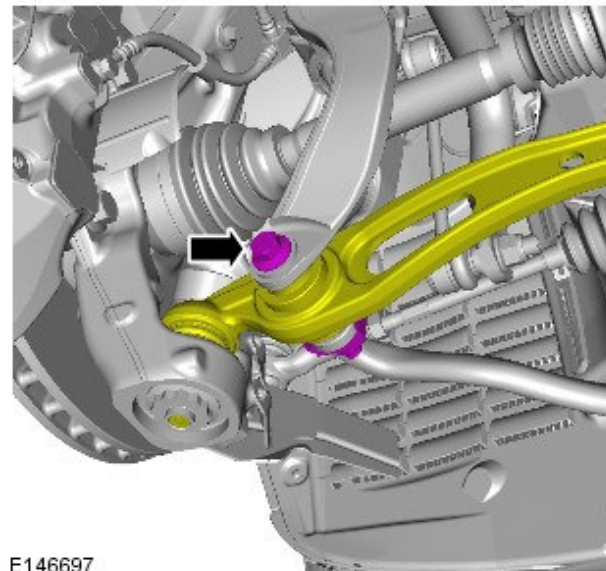

14.  **NOTE: M12 x 4 off Minimum Torque: 140Nm; M14 x 2 off Minimum Torque: 230Nm (refer to table 1).**

Dynamic Response Front Actuator Ski Bracket

- If the measured torque is less than the minimum residual torque shown, the fixing should be replaced with new and torque with reference to TOPIX Workshop Manual section 204:01: Front Suspension.

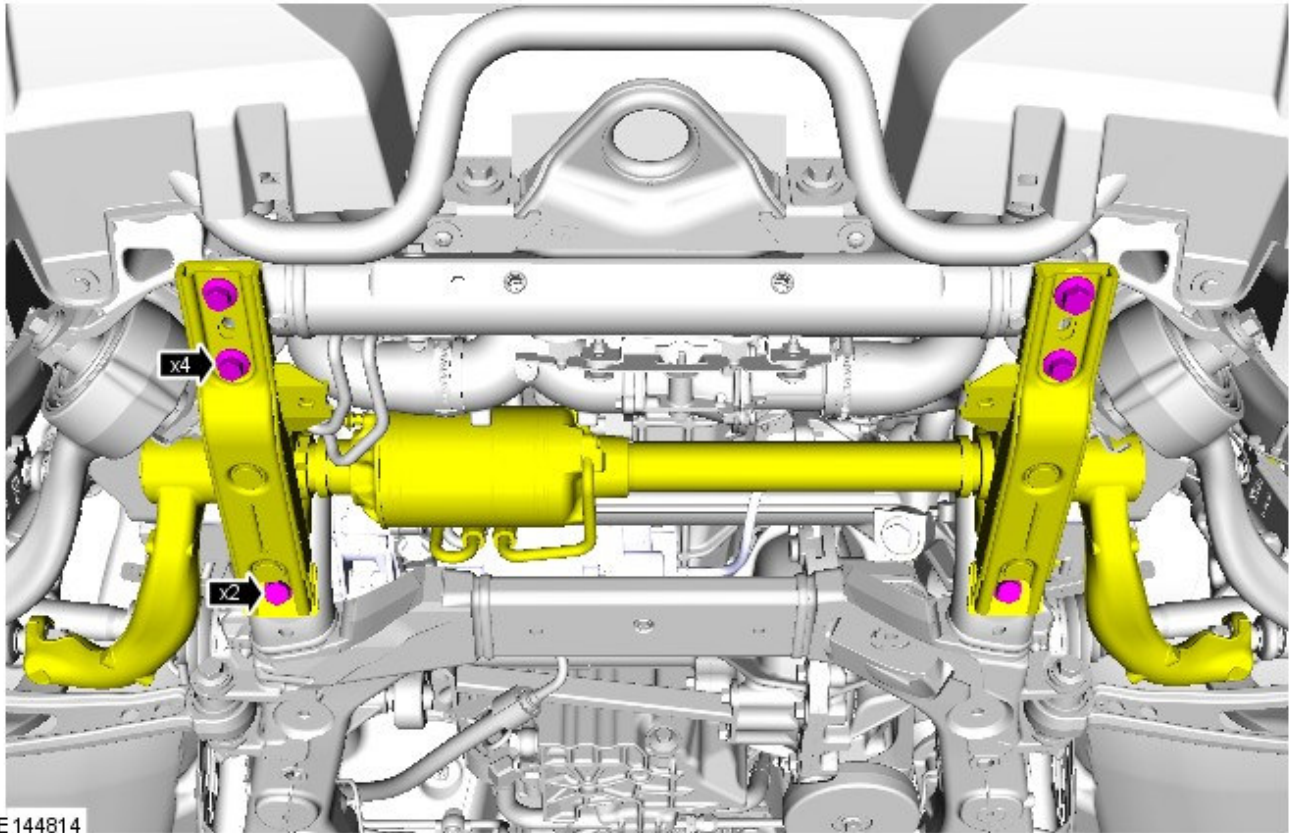

E144814

15.  **NOTE: Minimum Torque: 174Nm (refer to table 1).**

Front Stabilizer Links, Actuator Bar Arms to Knuckle

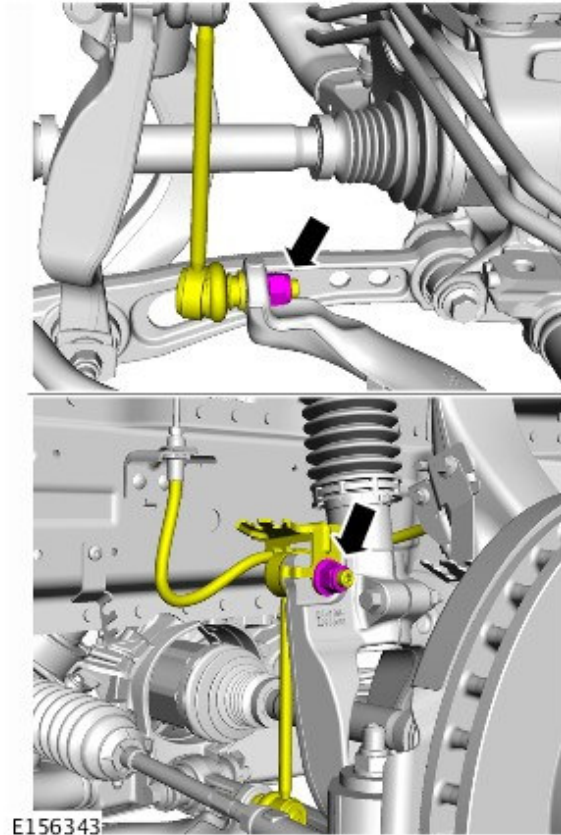

16.  **NOTE: Minimum Torque: 89Nm (refer to table 1).**

Pinch Bolt - Front Air Strut to Yoke

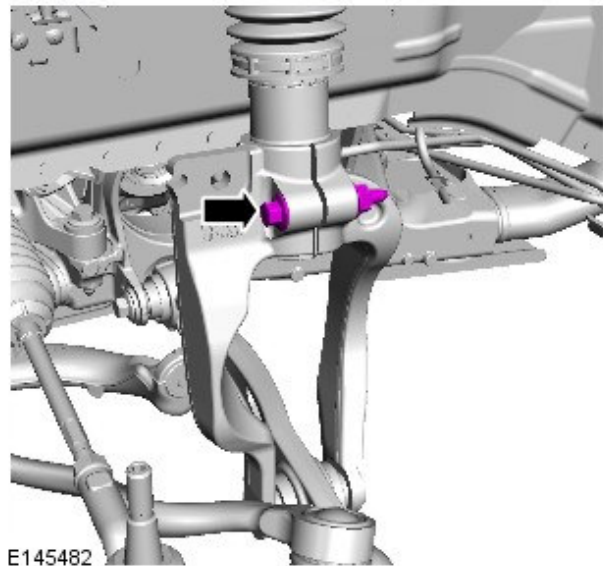

17.  **NOTE: Minimum Torque: 60Nm (refer to table 1).**

P1/P2 Upper Control Arm to Knuckle

- If the measured torque is less than the minimum residual torque shown, the fixing should be replaced with new and torque with reference to TOPIx

Workshop Manual section 204:01: Front Suspension.

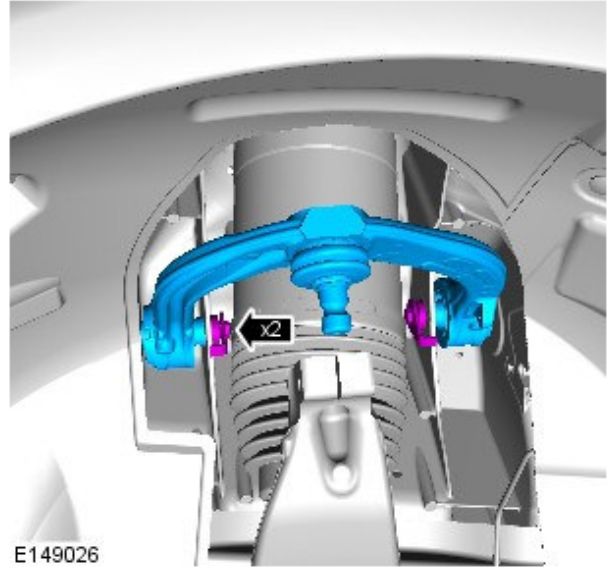

18.  **NOTE: Torque: 30Nm (refer to table 1)**
Tighten in a diagonal sequence.

Upper Fixings - Front Air Strut

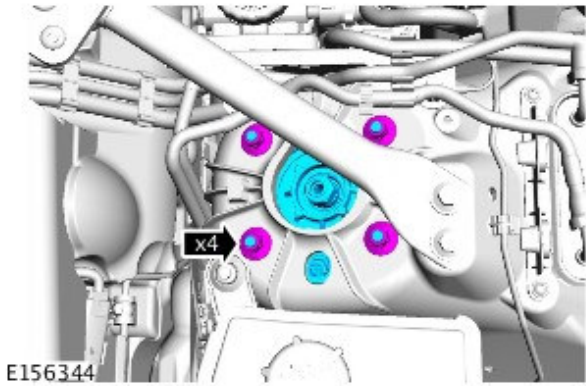

19. Check Pipes for Fouls

- Front pipe set to longitudinal. Check for a foul between the front hydraulic pipe set and the longitudinal.

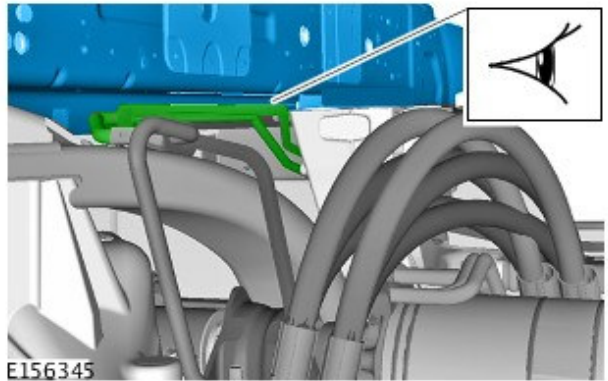

20. Front Pipe Set to Subframe

- Check that the rubber buffer is fitted to the hydraulic pipe. Ensure that there is not a hard foul between the hydraulic pipe and the sub frame.

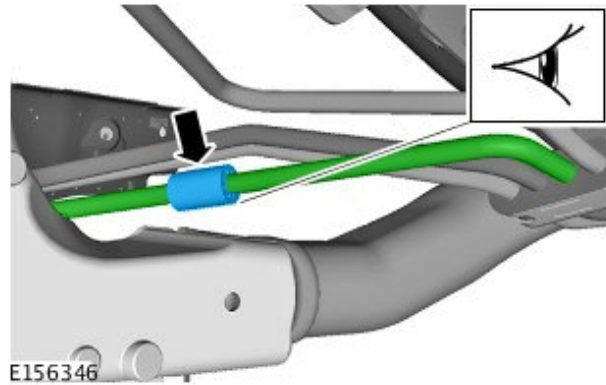

21. Return Hose to Longitudinal

- Check that the rubber buffer is fitted and that there isn't a hard foul between the return pipe/hose and the underside of the longitudinal.

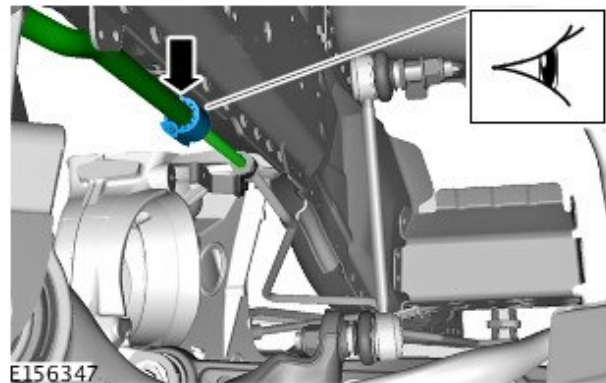

22. Rear Pipe to Aero Shield

- Check for a foul as the rear pipes exit from the aero under shield.
- Check the hydraulic pipe routing under the aero shield and ensure free of fouls to the fuel pipes.

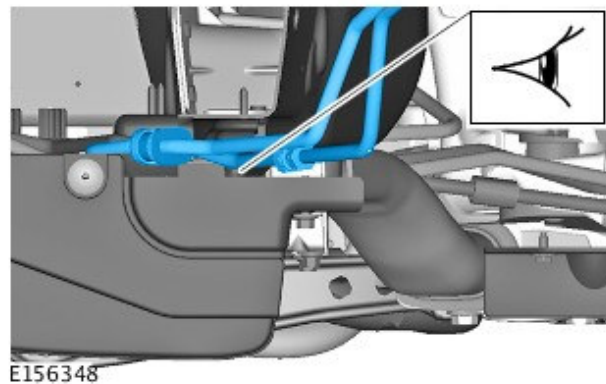

23. **NOTE: View of the end of hydraulic valve block from front of vehicle.**

Valve Block to Body Stud Clearance

- There should be sufficient clearance between the valve block body and the plastic body fastener that secures the fuel lines. Where no or very little clearance exists, the head of the fastener should be modified, by removing it and drilling an axial hole 5mm diameter through the head, so that the body stud passes through the head of the fixing.

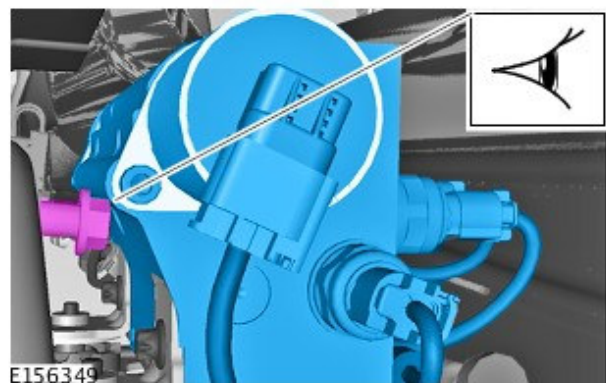

24. Front Pipes to Edge Clip on Subframe Ski Bracket (Front

right-hand)

- There should be sufficient clearance between the hydraulic pipes and the ski bracket.

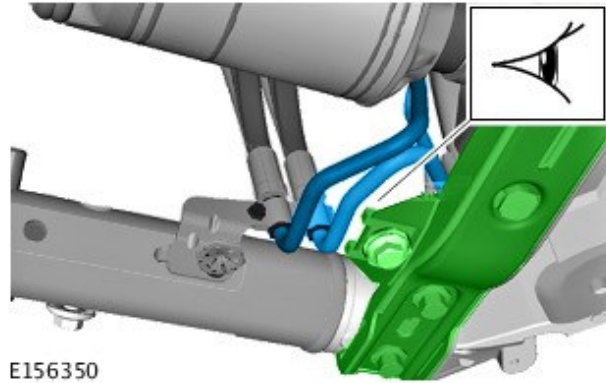

E156350

25. Carry out road test:

- If the issue is not still present, return the vehicle to the customer
- If the issue is still present, continue to the next step.

26.  **NOTE: If any of the six (6) Dynamic Response front actuator ski bracket bolts have been removed on three (3) previous occasions, steel inserts are required to be fitted into the subframe (see TOPIx Workshop Manual section 502-00: Thread repair inserts).**

2013MY vehicles: If the knocking noise is still present and considered unacceptable after performing above steps, replace the Dynamic Response front actuator (vehicles fitted with Dynamic Response System [part number LR052058], shown as **B** in E156543; see TOPIx Workshop Manual section 204-06: Ride and Handling Optimisation - Front Stabilizer Bar). **2014MY vehicles from VIN EA125193 will have the latest level parts already fitted.**

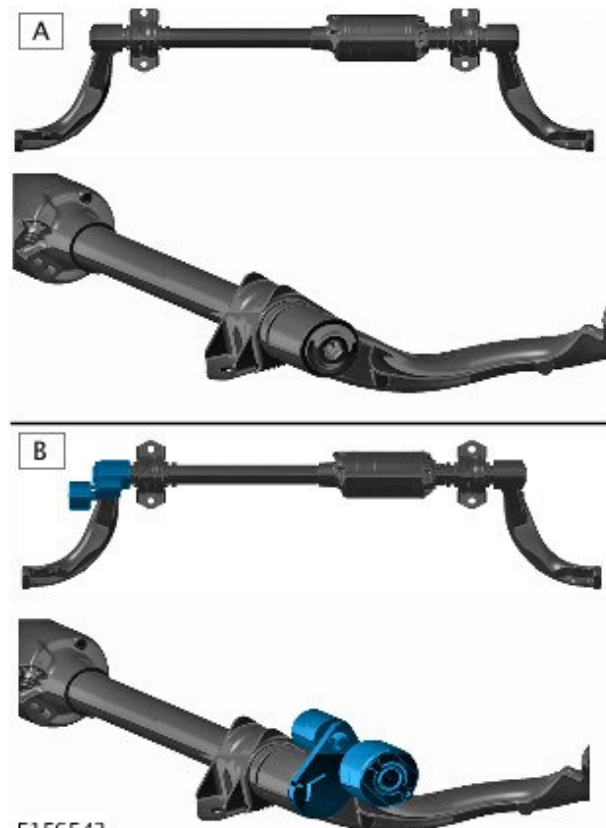

E156543

27.  **NOTE: If the knocking noise is still present and considered unacceptable after performing the above steps, remove and discard both under hood strut brace bars.**

Remove the cowl panel grille (see TOPIx Workshop Manual section 501-02: Front End Body Panels).

28. Remove both strut brace bars.

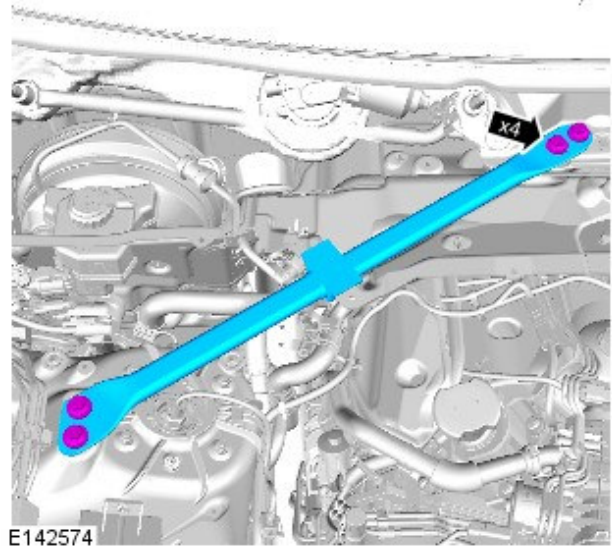

29. Remove the grommets from strut brace and discard both strut brace bars.

30.  **NOTE: One foam pad is sufficient for both strut brace bars.**

Insert foam pad (BTR6506; cut to a length of 38mm) into rear of the strut brace bar grommets as shown.

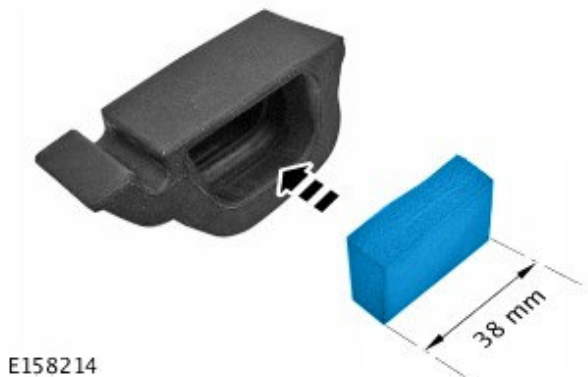

31. Insert the grommet as shown.



32.  **NOTE: Discard the four (4) fixing bolts that**

attach the brace bar to the bulk head (below wind screen).

Install strut brace bar bolts back into the struts as shown; tighten to 55Nm.

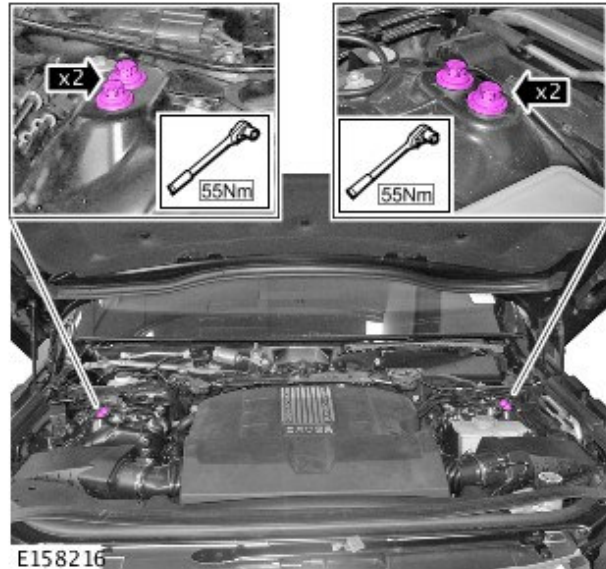

33. Install the cowl panel grille (see TOPIx Workshop Manual, section 501-02: Front End Body Panels).

34. After performing all listed remedial actions, it is possible that a low level of residual knocking noise may still be present. This low level of knocking noise may be caused by the Dynamic Response system's hydraulic operation. If the concern has not improved to an acceptable level, contact the Land Rover Technical HelpLine for further assistance.

TABLE 1: Torque Specification - Front Suspension

Joint Description	Torque	Nominal	Graphic
P1 Upper Control Arm to Body	60-90Nm	75Nm	E149026
P2 Upper Control Arm to Body (Rear Mount)	60-90Nm	75Nm	E149026
P3 Lower Control Arm to Frame	190-340Nm	n/a (torque + angle)	E156341
P4 Lower Control Arm to Frame	190-340Nm	n/a (torque + angle)	E146696
P6 Lower Ball Joint Knuckle (Lateral Arm)	290 ± 17Nm	290Nm	E146695
P7 Upper Control Arm to Knuckle	70 ± 10Nm	70Nm	E145575
P40 Lower Ball Joint Knuckle (Lower Arm Front)	290 ± 17Nm	290Nm	E156342
P56 Adaptive shock absorber Yoke to Lower Control Arm	210-340Nm	n/a (torque + angle)	E146697
Dynamic Response front actuator Ski Bracket M12 joints (x4)	140-230Nm	n/a (torque + angle)	E144814
Dynamic Response front actuator Ski Bracket M14 joints (x2)	230-300Nm	n/a (torque + angle)	E144814
Stabilizer Links, Actuator bar arms to knuckle	185 ± 11Nm	185Nm	E156343
Front Strut To Body - Upper	30Nm	30Nm	E156344
Front Strut To Yoke	89-101Nm	95Nm	E145482