



NEW FLYER

SERVICE MANUAL BULLETIN

This Service Manual Bulletin is prepared by the Publications Department of New Flyer Industries Canada ULC. Refer to details below.

SMB-135

ISSUE DATE: Aug 20 2014

APPLICABILITY					
VEHICLE LENGTH	<input type="checkbox"/> 30ft.	<input type="checkbox"/> 35ft.	<input type="checkbox"/> 40ft.	<input type="checkbox"/> 60ft.	<input checked="" type="checkbox"/> ALL
VEHICLE TYPE	<input type="checkbox"/> High Floor	<input type="checkbox"/> Low Floor	<input type="checkbox"/> Invero®	<input checked="" type="checkbox"/> Xcelsior®	<input type="checkbox"/> ALL
FUEL TYPE	<input type="checkbox"/> Diesel	<input type="checkbox"/> Electric	<input type="checkbox"/> CNG	<input type="checkbox"/> LNG	<input checked="" type="checkbox"/> ALL
	<input type="checkbox"/> Diesel/Electric	<input type="checkbox"/> Gas/Electric	<input type="checkbox"/> Fuel Cell		
SUBJECT	Steering Damper Inspection Interval & Criteria				
SECTION TITLE	PM - Preventive Maintenance				
DETAILS	<p>This bulletin provides a new inspection interval and criteria for the steering damper assembly installed on your New Flyer vehicle.</p> <p>This bulletin supersedes all prior information on this subject already provided in your New Flyer Service Manuals. Make this Service Bulletin available to service personnel to inform them of changed information.</p>				

1. Steering Damper

Inspect the steering damper every 6,000 miles (9,600 km) as follows:

- Check for excessive play at ball joints ends. See “Fig. 1: Steering Damper Inspection” on page 2.
- Inspect for any external damage to cylinder or piston rod. Replace damper if bent or damaged.
- Check for evidence of leakage. Replace damper if leaking.
- Inspect condition of protective sleeve on cylinder and ensure it can move freely and extend 2 to 3 inches from cylinder.
- Inspect exterior surfaces for evidence of corrosion. Clean light surface rust, otherwise replace damper if badly corroded.

NOTE:

If maintenance records indicate that the vehicle is experiencing front end steering shimmy, then a cylinder damping inspection should be performed.

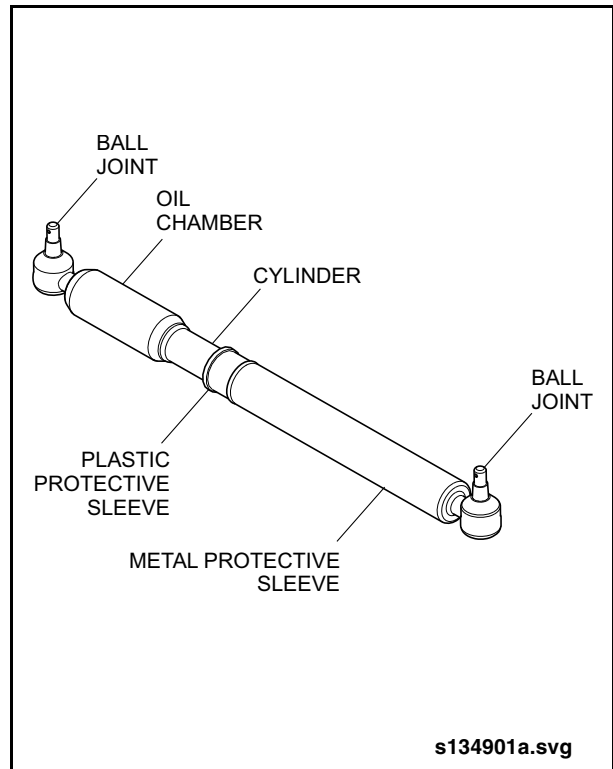

Fig. 1: Steering Damper Inspection



1.1. Cylinder Damping Inspection

1. Remove steering damper from vehicle. Refer to Section 3 of your New Flyer Service Manual for procedure.
2. Hold the steering damper in a vertical position with the oil chamber at the bottom.
3. Extend the piston rod fully by hand.
4. Operate the steering damper twice through its full range of travel in both compression and extension strokes.
5. Hold the steering damper fully extended in the vertical position for at least one minute.

NOTE:

Ensure that no pressure is applied to the piston rod while it is in the extended vertical position. The plastic protective sleeve should also be in the fully extended position.

6. Slowly compress the piston rod into the cylinder while noting both the resistance and distance travelled. Stop compressing the piston once resistance is felt.
7. Mark the position of resistance by scribing a line on the plastic protective sleeve that coincides with the position of the metal protective sleeve.
8. Retract the piston upwards until the plastic protective sleeve is fully extended. Measure the distance between the edge of the metal protective sleeve and the mark scribed on the plastic protective sleeve. See "Fig. 2: Damper Measurement" on page 3.

9. The piston rod must not travel more than 0.118 in. (3.0 mm) before damping resistance is felt. Replace steering damper if free travel (slip) exceeds these limits.
10. Reinstall steering damper on vehicle. Refer to Section 3 of your New Flyer Service Manual for procedure.

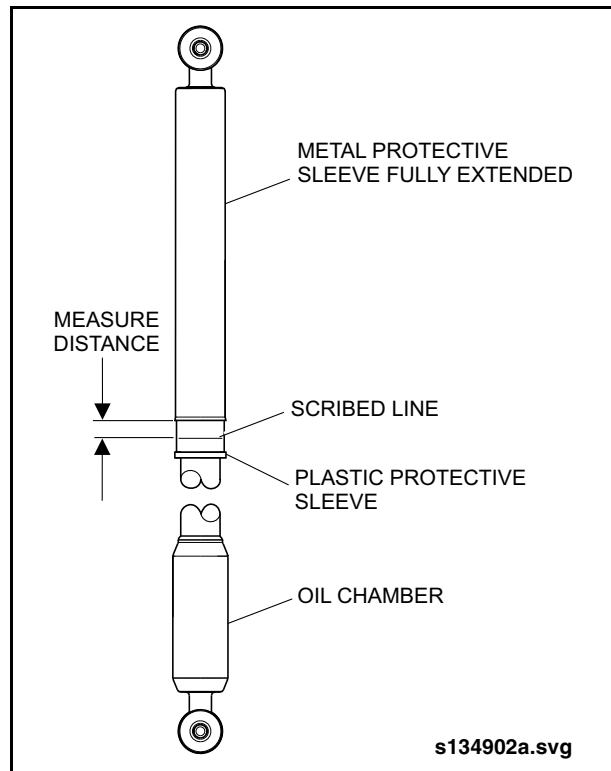

Fig. 2: Damper Measurement