



INSTRUCTION TO SERVICE

ITS: 5850	
SECTION:	350 Drivers Controls
WRITTEN BY:	Ken Chubaty
SUBJECT:	Replace old stock Smartrend Foot Switches with new stock (improved) Smartrend Foot Switches

ITS5850

THIS DOCUMENT AND THE CONTENTS DISCUSSED HEREIN ARE THE CONFIDENTIAL AND PROPRIETARY INFORMATION OF NEW FLYER INDUSTRIES CANADA ULC AND NEW FLYER OF AMERICA INC. AND ARE DISCLOSED BY NEW FLYER IN CONFIDENCE. THIS DOCUMENT AND THE CONTENTS HEREIN ARE NOT TO BE DISCLOSED BY THE INTENDED RECIPIENT WITHOUT THE PRIOR WRITTEN AUTHORIZATION OF NEW FLYER. ANY UNAUTHOIZED DISCLOSURE, REPRODUCTION OR OTHER DISTRIBUTION OF THIS DOCUMENT OR INFORMATION IS STRICTLY PROHIBITED AND MAY RESULT IN ACTION BEING TAKEN AGAINST THE PARTY MAKING THE UNAUTHORIZED DISCLOSURE. THIS DOCUMENT AND ALL COPIES HEREOF MUST BE RETURNED TO NEW FLYER UPON REQUEST.

PROCEDURE:

1. Turn the main battery disconnect switch to the “OFF” position.
2. At the driver’s area, locate the turn signal foot switches.

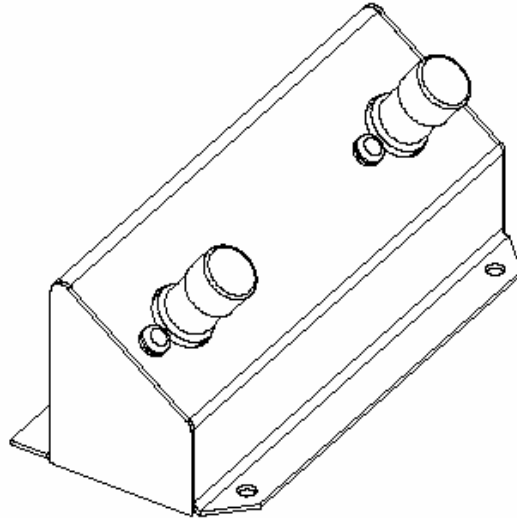

Figure 1: Turn Signal Foot Switches

3. To access, remove, and inspect the foot switches; the entire assembly must be pulled up from the floor to gain access to the bottom side of the switch.

NOTE: Use caution to not damage the wiring when removing the assembly.

4. Disconnect the wiring from each switch.
5. Remove the screws from the top of the assembly to allow the switches to slip out from the bottom.
6. Inspect each switch for a Smartrend stamp on the side.



Figure 2: Smartrend Foot Switch Stamp



NEW FLYER

7. If the switch has the stamp, it is the latest iteration of the switch and should be used. If it does not have any stamps, the switch can be discarded.
8. Using the new switch (PN 5925959) which does have the Smarttrend stamp on the side, install it in place of the old switch. The same hardware can be used.
9. Re-wire the switches with the existing wiring. See Figure 3 for reference.

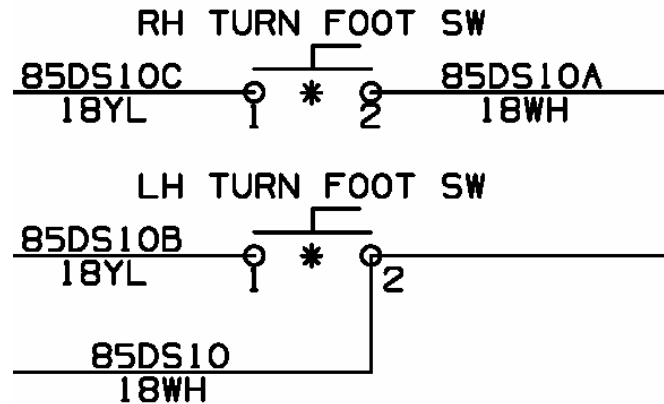

Figure 3: Turn Signal Foot Switch Wiring

10. Reinstall the foot switch assembly to the floor.
11. Turn the main battery disconnect switch to the "ON" position.
12. Turn the MRS to the RUN position and ensure both turn signal foot switches work correctly.



NEW FLYER

LABOUR ESTIMATE

	Operation	Men	Hours	Labour Time M X HR
1	Replace old stock Smartrend Foot Switches with new stock (improved) Smartrend Foot Switches	1	0.5	0.5

PARTS REQUIRED

Item	Part Number	Description	Qty. per Coach	Units	Notes
1	5925959	SWITCH-FOOT, TURN SIGNAL/PA MOD	2	EA	