

## JERR-DAN CORPORATION

CUSTOMER SUPPORT  
13224 FOUNTAINHEAD PLAZA  
HAGERSTOWN, MD 21742  
Phone: (800) 926-9666  
Fax: (301) 745-5375  
www.jerr-dan.com

### Service Letter Reference: JD 14-126

**Date:** May 6, 2014

**To:** Jerr-Dan Customer Dealers and Service Providers

**Models Affected:** Jerr-Dan Heavy Duty Wreckers, Including 25 Ton, 35 Ton, 50 Ton, and HDR1000 Models

**Subject:** Weld Inspection on Sheave Support Weldments

**Issue:**

Jerr-Dan has determined that sheave support weldments, (P/Ns 3249000008, 3249000010, 3249000011, and 3249000015) on certain Heavy Duty Wrecker units, may exhibit insufficient welds, which could result in a failure of the sheave support weldment. If your sheave support weldment is missing any of the welds in the highlighted weld pattern, replacement is necessary. Reference the illustration below:

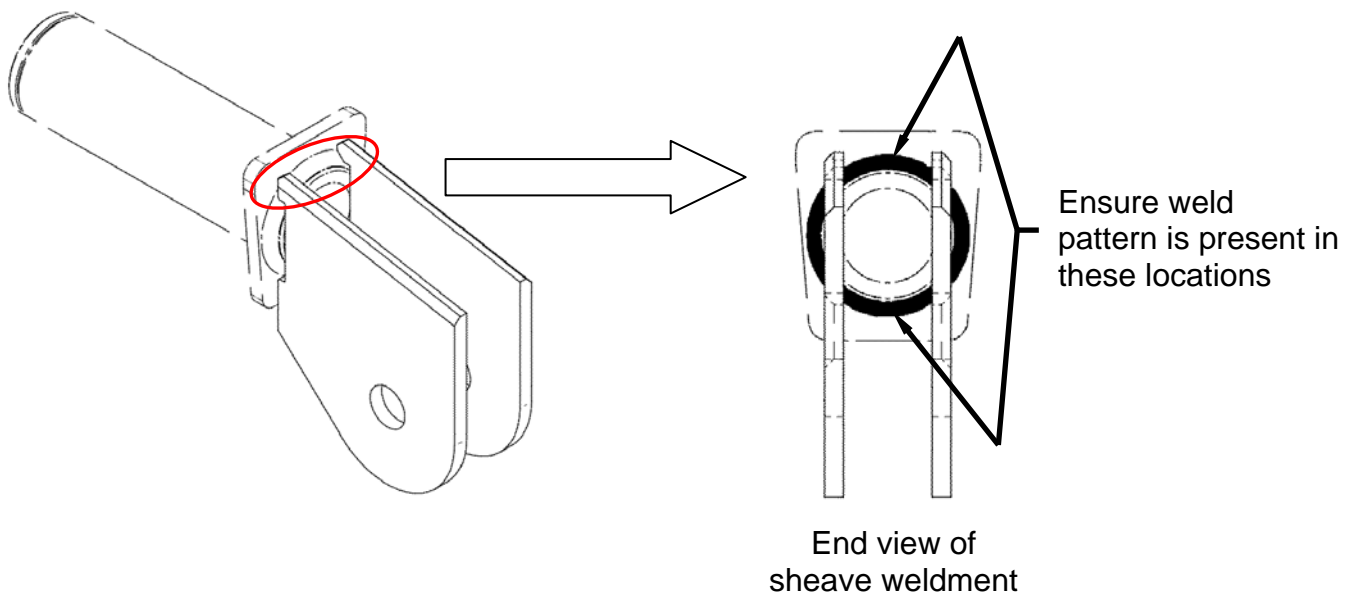

**Resolution:**

Jerr-Dan has worked with the sheave support weldment manufacturer to ensure that the correct weld pattern is being used. It is recommended that the sheave support weldment be inspected for proper weld pattern. If weld pattern is incorrect, replacement of the sheave support weldment is necessary. Please follow the Jerr-Dan Sheave Support Weldment Replacement Instructions, included for your reference, to ensure proper installation.

**Warranty:**

Jerr-Dan recommends the inspection of the sheave support weldment within the next 30 days. If replacement is required, Jerr-Dan will reimburse your account the cost of the part, and three (3.0) hours labor for each unit completed. No travel will be paid in accordance with this Service Letter. This bulletin will expire 6 months after the date of distribution. Please reference JD 14-126 on your warranty claim.

The replacement part can only be ordered by a local servicing entity of Jerr-Dan products. This servicing entity must have a Jerr-Dan account and be capable of purchasing parts and filing warranty claims. When ordering a part, the servicing entity will be charged (debited) for the cost of each part.

Should you have any questions or concern, please contact Jerr-Dan Customer Support.

Regards,

Jerr-Dan Customer Support

**Enclosures**

- Jerr-Dan Sheave Support Weldment Replacement Instructions
- Master Serial Number Listing of Affected Units
- Owner Update Form
- Individual Serial Number Listing

## JERR-DAN CORPORATION

---

CUSTOMER SUPPORT  
13224 FOUNTAINHEAD PLAZA  
HAGERSTOWN, MD 21742  
Phone: (800) 926-9666  
Fax: (301) 745-5375  
www.jerr-dan.com

## Jerr-Dan Sheave Support Weldment Replacement Instructions

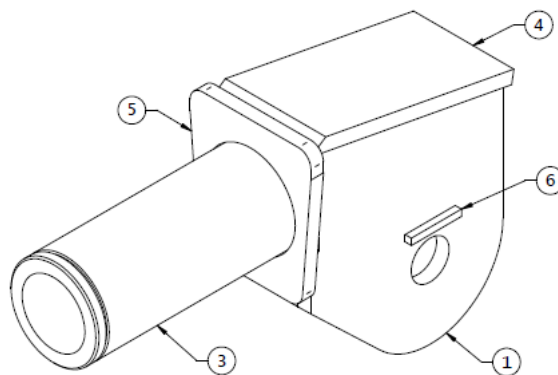

### **IMPORTANT:**

When removing the wire rope from the winch drum and reinstalling, reference the Winch Operators Manual for proper instructions and manufacturer specifications.

1. Remove wire rope from winch drum.
2. Remove "C" Style retaining clip from the rear of the sheave support weldment.
3. Slide the sheave support weldment out of the boom. Take to work bench area.
4. Remove the pin and keepers from the center of the sheave and remove the cable guide weldment.
5. Remove the old sheave support weldment and discard.
6. Reuse the pin and keepers and reinstall the cable guide weldment on the new sheave support weldment.
7. Slide the sheave support weldment and cable guide weldment back into the boom.
8. Reinstall the "C" Style retaining clip at the rear of the sheave support weldment.
9. Reinstall the wire rope back onto the winch drum. Please refer to the winch Operators Manual to ensure the wire rope is installed per manufacturer specifications.

**Master Serial Number Listing of Affected Units**

0230000763	0230001420
0230000771	0230001466
0230000802	0230001467
0230000803	0230001479
0230000944	0230001493
0230000984	0230001494
0230001119	0230001509
0230001174	0230001539
0230001197	0230001547
0230001198	0230001548
0230001200	0230001563
0230001208	0230001568
0230001209	0230001573
0230001215	0230001588
0230001216	0230001589
0230001217	0230001594
0230001224	0230001603
0230001225	0230001617
0230001233	0230001618
0230001250	0230001623
0230001261	0230001649
0230001262	0230001659
0230001263	0230001676
0230001274	0230001682
0230001310	0230001691
0230001327	0230001692
0230001407	0230001707
0230001408	0230001717



**Product Owner Update Form**

- Complete ALL Sections of this form and mail or fax to the appropriate location specified below.
- It is very important to keep Jerr-Dan updated with current product ownership information. By registering the products you own, you can ensure that Jerr-Dan will be better prepared to serve you and provide support.
- DO NOT include Lessees/Renters of Leased/Rented Products on this form.
- To report a *Scrapped, Stolen, Missing, or Recovered product*, use the "Jerr-Dan Product Status Verification Form No. PSR015-JDC."

**Product Information**

Make: \_\_\_\_\_ Model: \_\_\_\_\_

Serial Number or VIN/PIN: \_\_\_\_\_

Make: \_\_\_\_\_ Model: \_\_\_\_\_

Serial Number or VIN/PIN: \_\_\_\_\_

Make: \_\_\_\_\_ Model: \_\_\_\_\_

Serial Number or VIN/PIN: \_\_\_\_\_

Make: \_\_\_\_\_ Model: \_\_\_\_\_

Serial Number or VIN/PIN: \_\_\_\_\_

**Contact Information**

Company Name: \_\_\_\_\_

Street Address: \_\_\_\_\_ Address1: \_\_\_\_\_

City: \_\_\_\_\_ State/Province: \_\_\_\_\_ Zip/Postal Code: \_\_\_\_\_ Country: \_\_\_\_\_

Telephone: \_\_\_\_\_ Facsimile: \_\_\_\_\_ E-Mail Address: \_\_\_\_\_

Contact Name: \_\_\_\_\_ Signature: \_\_\_\_\_ Date: \_\_\_\_\_

**\*Product Owner Information**  (Same as Contact)

Company Name: \_\_\_\_\_

Street Address: \_\_\_\_\_ Address1: \_\_\_\_\_

City: \_\_\_\_\_ State/Province: \_\_\_\_\_ Zip/Postal Code: \_\_\_\_\_ Country: \_\_\_\_\_

Telephone: \_\_\_\_\_ Facsimile: \_\_\_\_\_ E-Mail/Website Address: \_\_\_\_\_

**Mail or Fax Completed Form to:**

**Jerr-Dan Corporation  
Product Safety & Reliability Department  
13224 Fountainhead Plaza  
Hagerstown, MD 21742**

**Facsimile: 301/745-3713  
Email: productsafety@jerr-dan.com**