

Date	Group	No.	Release	Page
11.2014	214	019	01	1(18)

Rocker Arms, Replacement
and Injector Re-torque
MP10 US2014
TD

PI0856, Rocker Arms, Replacement and Injector Re-torque

(November 2014)

Mack Trucks has authorized replacement of the exhaust brake rocker arms and injector re-torque on vehicles built between 09/03/2014 and 10/27/2014 with MACK MP10 US2014 engines. The engine brake rocker arms must be changed on all vehicles involved in this campaign. Before proceeding, verify campaign eligibility by checking Service Program status in VDA.

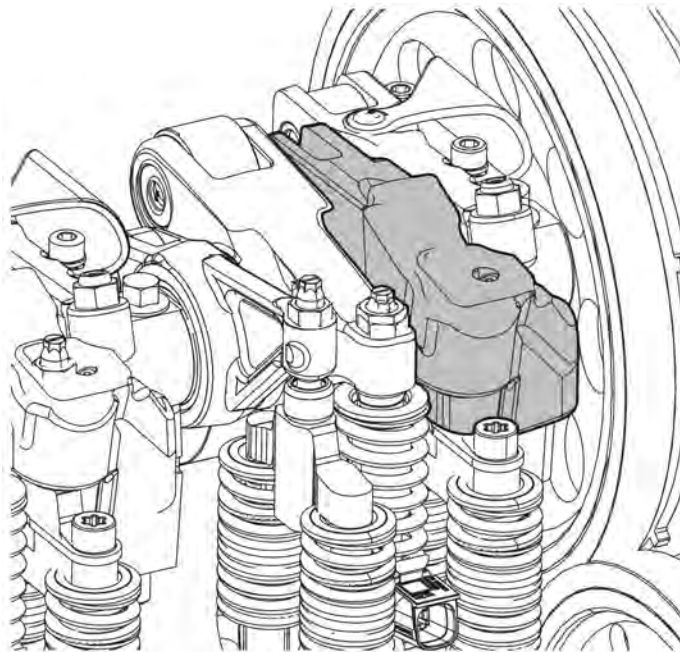

W2005872

Procedure

You must read and understand the precautions and guidelines in Service Information, Function Group 20, Engine Safety Practices, before performing this procedure. If you are not properly trained and certified in this procedure, ask your supervisor for training before you perform it.

Special tools: 9989876, 9999696, 85109035, 85111377, 85111493, 88800014

- 1 Secure the vehicle for service by parking it on a flat level surface, applying the parking brake, chocking the rear wheels, and placing the transmission in neutral or park.
- 2 Disconnect all cables from the negative (ground) battery terminals to prevent personal injury from electrical shock and prevent damage to electrical components
- 3 Remove the valve cover. Refer to Function Group 21.
- 4 Cut the tie straps securing the electrical harness to the engine brake control valve.

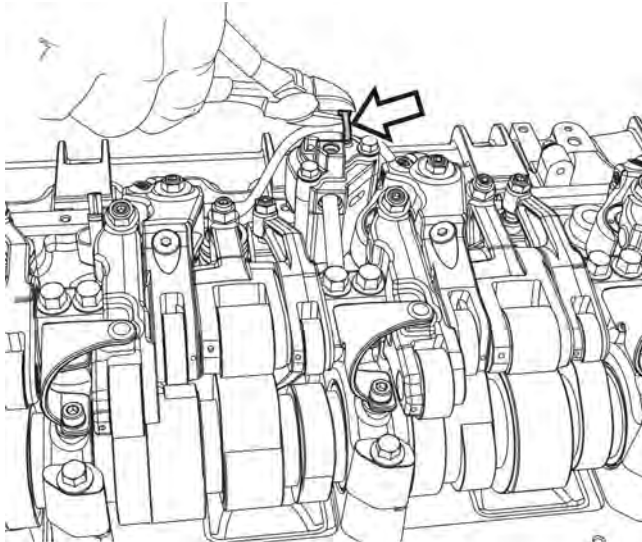

W2005846

- 5 Clean around the engine brake control valve and remove the control valve electrical harness connector from the bottom of the control valve.



W2004837

- 6 Remove the engine brake control valve mounting bolts. Remove the control valve, oil pipe and valve seal spacer off the cylinder head.

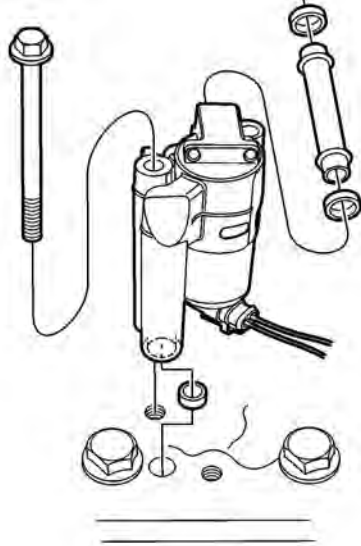

W2004869

- 7 To prevent piston damage when removing the rocker arm shaft, secure the pistons in the exhaust rocker arms with elastic bands or tie straps so that the pistons do not fall out as the rocker arm shaft is removed.

Note: Pistons and rocker arms are matched together and should not be mixed during reassembly.

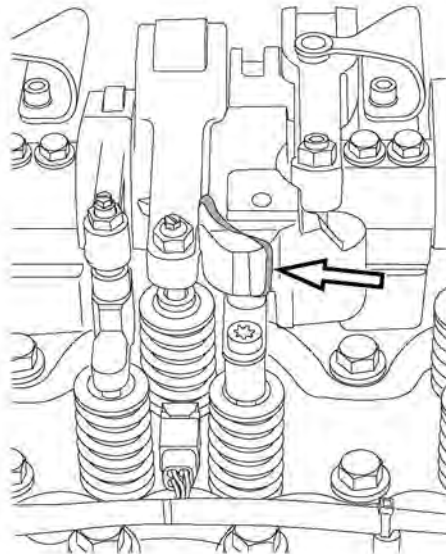

W2006172

- 8 Use an Allen wrench to remove the fasteners securing the leaf springs to the engine brake control valve rocker arms. Remove the leaf springs.

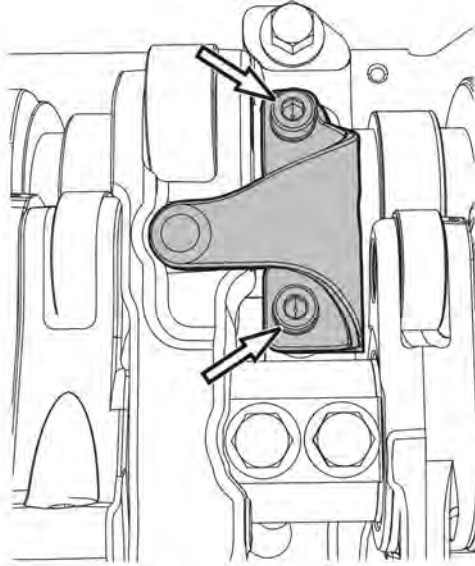

W2005845

- 9 Remove the plug from the flywheel housing and install the flywheel turning tool.

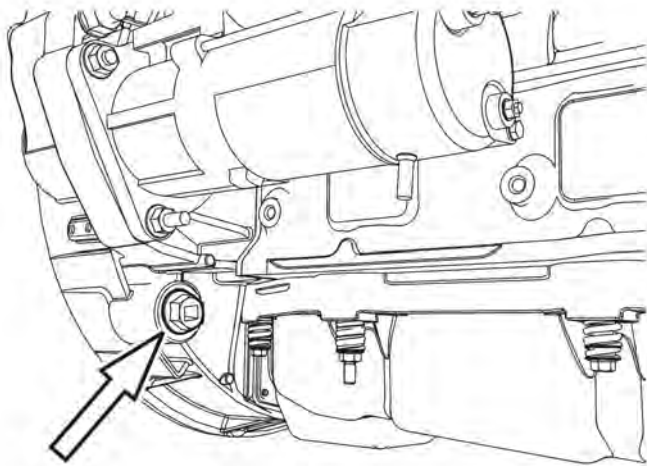

W0002368

- 10 Use the flywheel turning tool to rotate the camshaft so it is positioned at top dead center (TDC). Align the TDC mark on the camshaft with the timing marks on the No. 1 camshaft bearing cap.

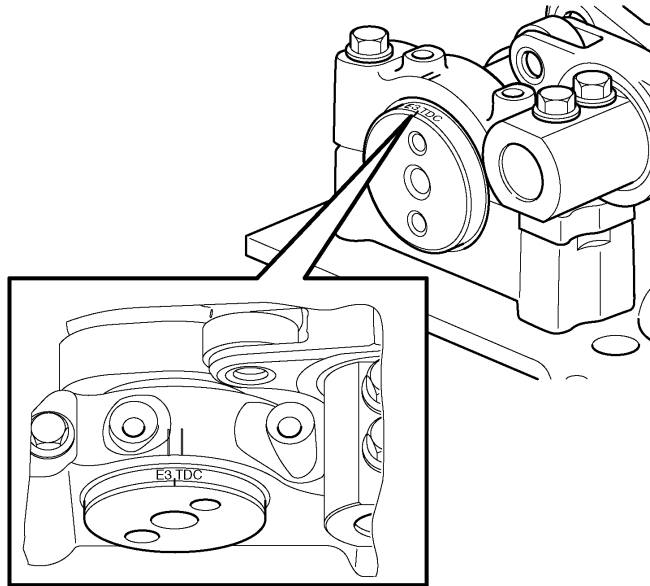

W2006173

- 11 Loosen the jam nuts and back off all rocker arm and fuel injector adjusting screws.

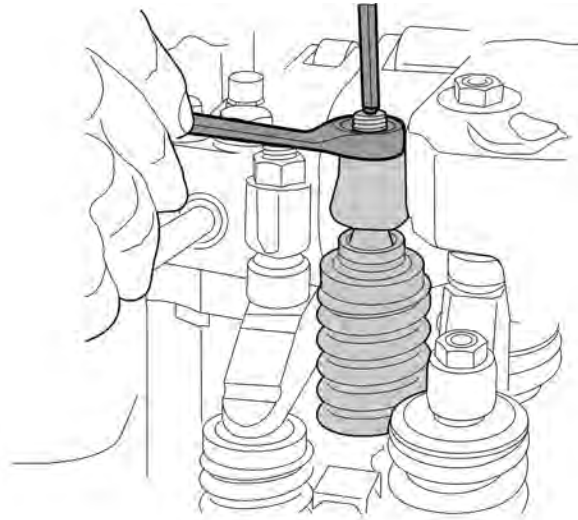

W2005816

- 12 Loosen the rocker arm shaft mounting fasteners (evenly in stages to avoid bending the shaft) until all the fasteners are removed.
- 13 Carefully attach the rocker assembly lifting tool to the rocker arm shaft assembly.
- 14 With the aid of an assistant, remove the rocker arm shaft assembly using the rocker assembly lifting tool. Place the rocker arm shaft assembly in a secure location until time to disassemble and inspect the components.

Note: Ensure that the pistons are secured in the exhaust rocker arms with elastic bands so that the pistons do not fall out as the shaft is removed.

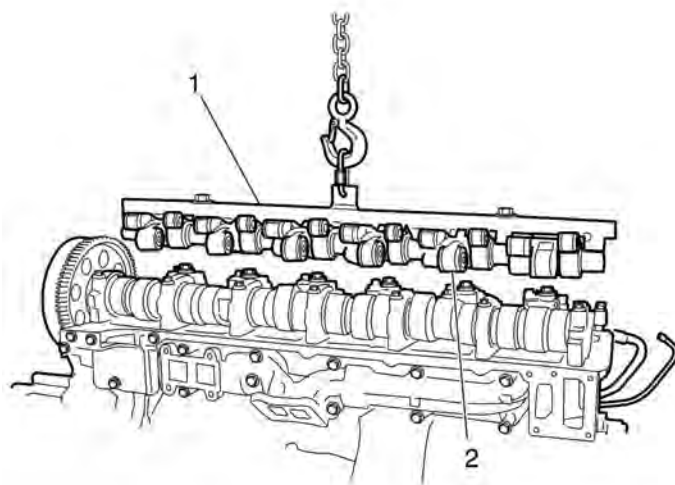

W2005513

1.	Rocker Assembly Lifting Tool
2.	Rocker Arm Shaft Assembly

- 15 Using the rocker assembly lifting tool and the aid of an assistant, place the rocker arm shaft assembly on a workbench; remove the lifting tool.

16 Note the position of the rocker arms on the shaft and mark them for reassembly at the same location. When their positions have been noted, remove all the rocker arms from the rocker arm shaft.

Note: Check that the pistons in the exhaust rocker arms are fastened with elastic bands or similar to prevent the pistons from falling out. Pistons and rocker arms are matched sets, so, the one, two or three punch marks on the rocker arm and piston should correspond.

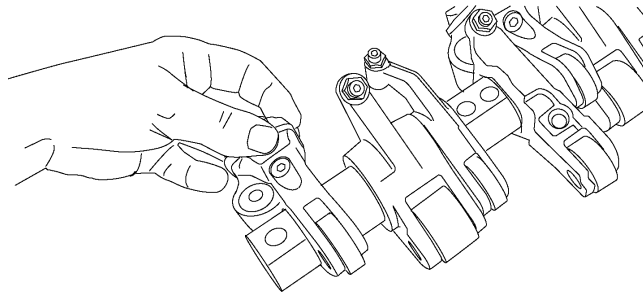

W2006231

17 Discard the exhaust brake rocker arms. Inspect all other rocker arms and replace any that show signs of wear or damage.

Note: Ensure that the pistons are secured in the new exhaust rocker arms with elastic bands so that the pistons do not fall out.

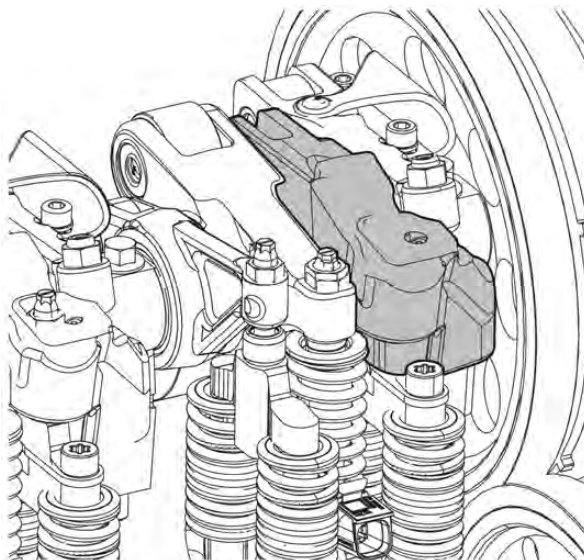

W2005872

- 18 Inspect the rocker arm shaft for wear or damage and repair or replace as needed.
- 19 Lubricate the rocker arms and rocker arm shaft with clean engine oil. When replacing a rocker arm, lubricate the new rocker arm bearing. Using an oil can, insert the oil can nozzle into the oil channel hole and rotate the roller while injecting the oil and checking that the oil comes out on both sides of the roller.

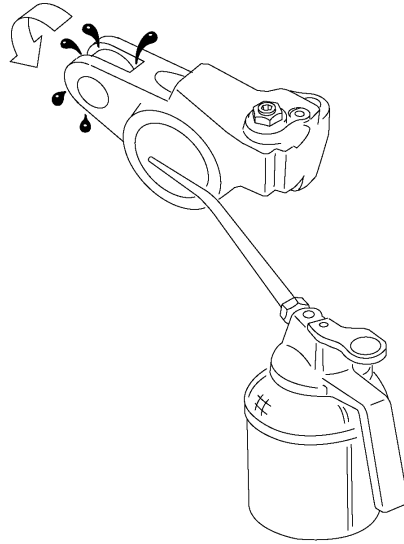

W2005940

- 20 Install all the rocker arms on the rocker arm shaft at the proper locations and check that they move freely. All reused rocker arms should be installed at their original locations.

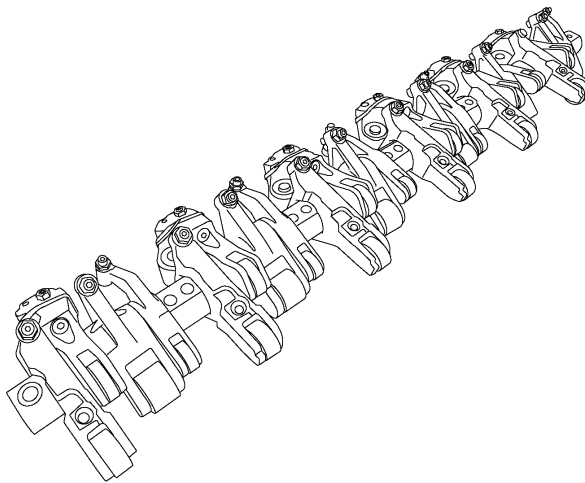

W2006241

21 Before installing the rocker arm shaft assembly, re-torque the injectors. Loosen the hold down bolts 100 to 110 degrees until torque is 10 to 15 Nm (7 to 11 ft-lb). Tighten the hold down bolts to 20 ± 5 Nm (15 ± 4 ft-lb). Tighten hold down bolts an additional 90 ± 5 degrees.

Note: Do not completely loosen the injector hold down bolts to prevent components from moving. Do not remove the injectors.

22 With all the rocker arms in place on the rocker arm shaft, carefully attach the lifting tool to the rocker arm shaft assembly.

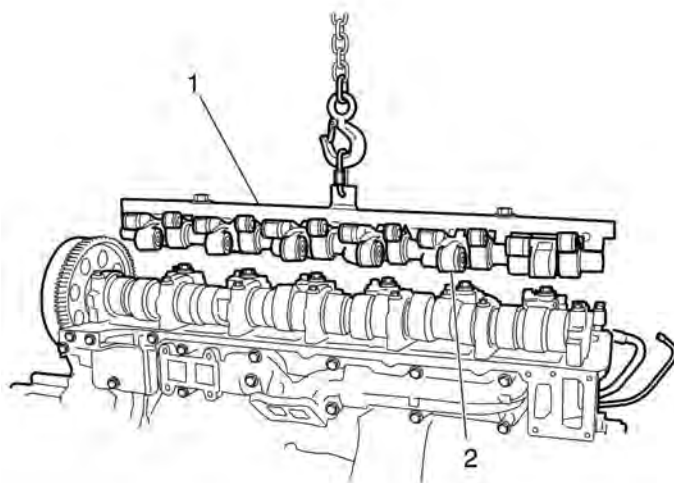

W2005513

1.	Rocker Assembly Lifting Tool
2.	Rocker Arm Shaft Assembly

23 Before installing the rocker arm shaft assembly on the engine, oil the valve bridges and camshaft lobes with clean engine oil.

24 Using the rocker assembly lifting tool and the aid of an assistant, position the rocker arm shaft assembly over the camshaft bearing caps.

25 Remove the rocker assembly lifting tool from the rocker arm shaft assembly.

26 Install the rocker arm shaft mounting bolts by tightening the mounting bolts a little at a time, evenly across the entire shaft so that the shaft does not become distorted, bent or fractured.

Note: Verify that the rocker arm shaft is properly seated in the guide dowels of the camshaft bearing caps.

27 Remove the elastic bands or tie straps retaining the exhaust rocker arm pistons.

28 To ensure that the rocker arm shaft, camshaft bearing caps and bearing saddles are fully seated, tighten all camshaft bearing cap and rocker arm shaft bolts to specification.
Tighten the bolts in the numbered steps to make sure that the rocker arm shaft is installed without bending or distortion.

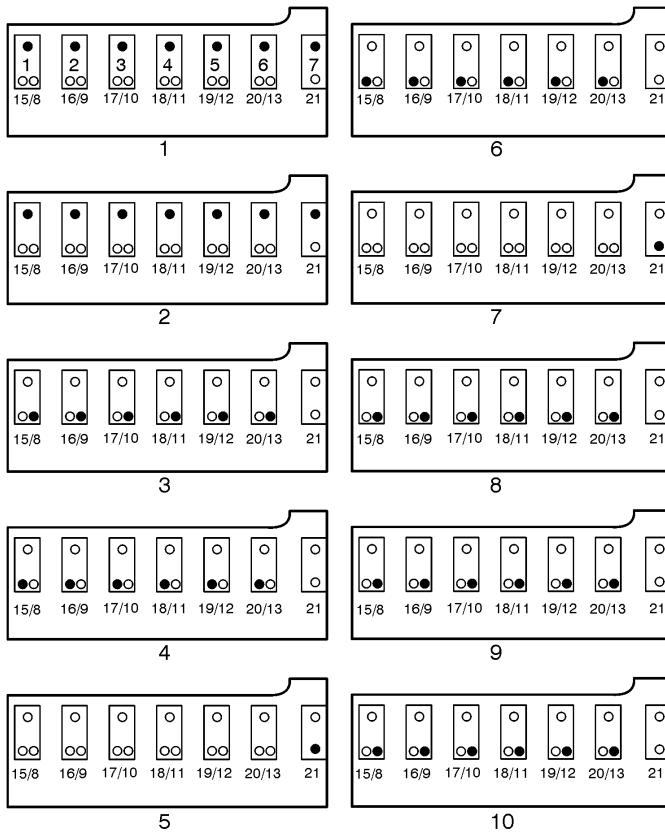

W2005266

Step 1. Tighten bolts 1–7 to 1.5 ± 3 Nm (11 ± 2 ft-lb)
Step 2. Angle tighten bolts 1–7 to 90 ± 5 degrees
Step 3. Tighten bolts 11, 10, 12, 9, 13, 8 in gradual steps to contact, then tighten to 100 ± 10 Nm (74 ± 7 ft-lb)
Step 4. Tighten bolts 15–20 to 50 ± 5 Nm (37 ± 4 ft-lb)
Step 5. Tighten bolt 21 to 6.0 ± 5 Nm (44 ± 4 ft-lb)
Step 6. Angle tighten bolts 15–20 to 120 ± 5 degrees
Step 7. Angle tighten bolt 21 to 100 ± 5 degrees
Step 8. Loosen bolts 8–13
Step 9. Tighten bolts 8–13 to 50 ± 5 Nm (37 ± 4 ft-lb)
Step 10. Angle tighten bolts 8–13 to 120 ± 5 degrees

29 Replace the O-ring at the bottom of the engine brake control valve, if equipped.

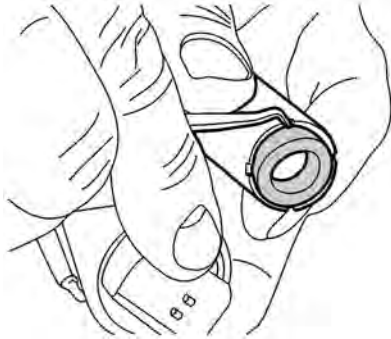

W2004855

30 Clean the engine brake control valve oil pipe and replace the O-rings. Lubricate the oil pipe hole in the rocker arm shaft and the O-rings on the oil pipe.

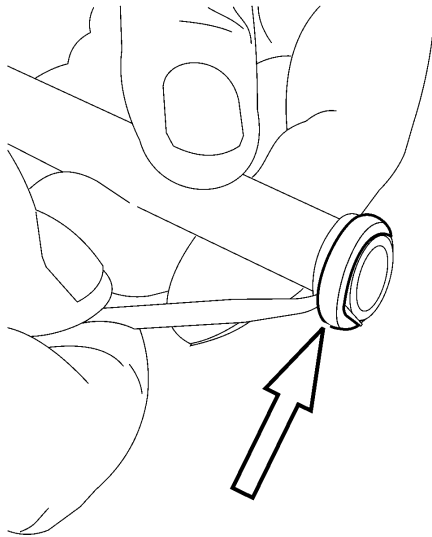

W2004853

31 Insert the oil pipe into the oil hole of the engine brake control valve. Make sure that the oil pipe O-ring is fully seated in the engine brake control valve.

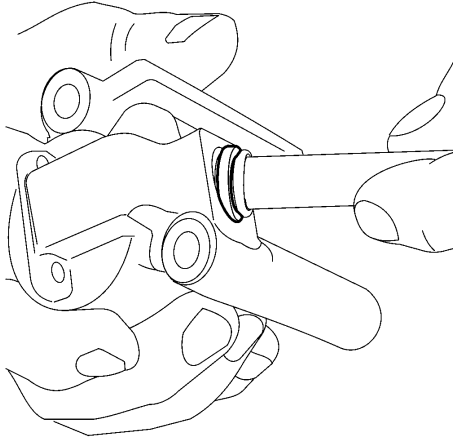

W2004854

32 Install a new engine brake control valve seal spacer onto the cylinder head. Make sure that the seal spacer is correctly seated with the lip of the spacer against the cylinder head.

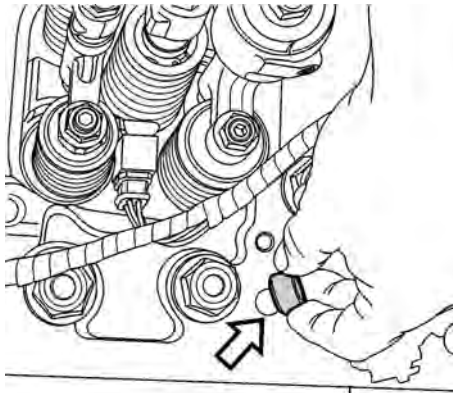

W2004840

33 Position the engine brake control valve on the cylinder head.

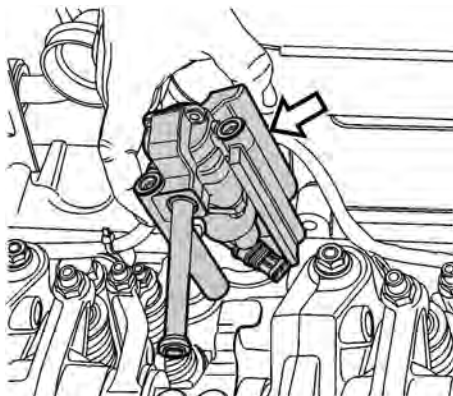

W2004839

34 Align the engine brake control valve with the seal spacer.

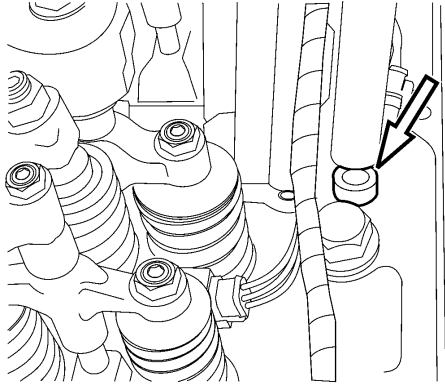

W2004856

35 Align the engine brake control valve oil pipe and O-ring with the hole in the rocker shaft.

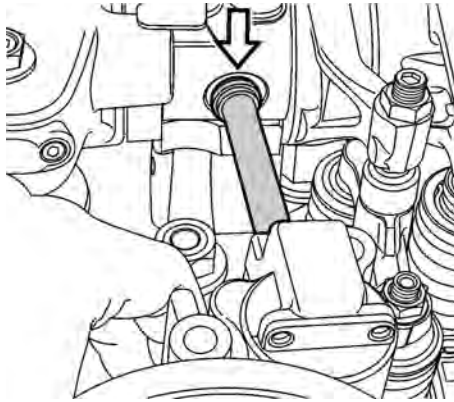

W2004857

36 Install the engine brake control valve bolts and tighten to 20 ± 3 Nm (15 ± 2 ft-lb). Make sure the engine brake control valve oil pipe O-ring is fully seated in the valve and rocker arm shaft.

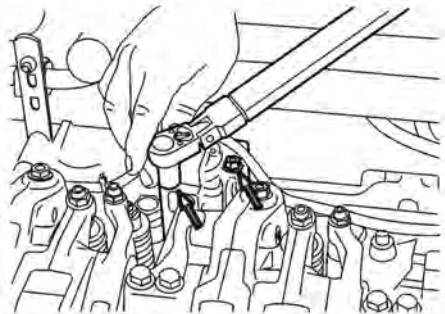

W2004858

37 At the bottom of the engine brake control valve, plug in the control valve harness electrical connector.



W2004837

38 Position the fuel injector electrical harness over the engine brake control valve and secure with tie straps.

39 Before adjusting the valves, verify that the camshaft alignment marks are between the two lines on the camshaft bearing cap.

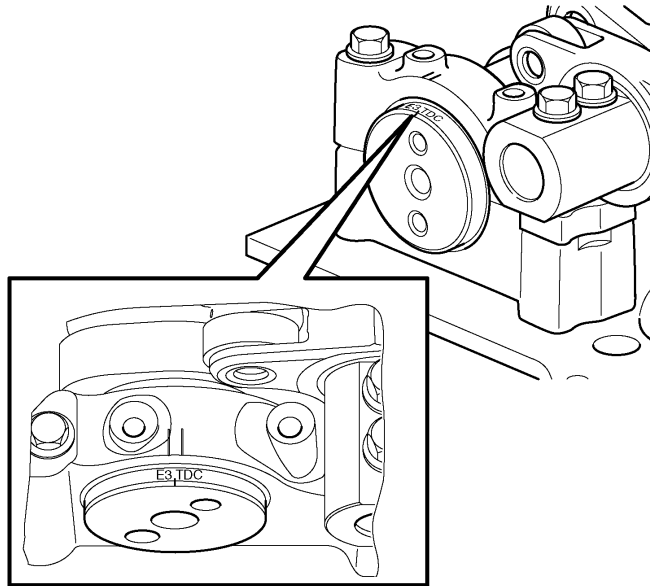

W2006173

- 40 Adjust the valves and injectors. Refer to Function Group 21. Use the flywheel turning tool as needed to rotate the engine.
- 41 Place the leaf springs in position on the camshaft bearing caps and install the fasteners. Tighten the fasteners to 25 ± 3 Nm (18 ± 2 ft-lb).

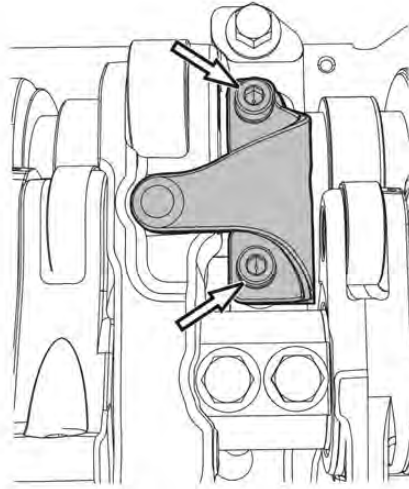

W2005845

- 42 Remove the flywheel turning tool from the flywheel housing and install the dust plug.
- 43 Carefully inspect the valve cover gasket for damage and replace with a new gasket if necessary. Make sure that the gasket is properly seated in the valve cover channel and follows the contour of the channel.
- 44 Apply a 2 mm (0.079 inch) bead of approved sealant across the parting line between the timing gear cover and the cylinder head. This parting line is on both sides of the cylinder head.

Note: This step is critical to prevent leaks.

Note: The valve cover must be installed within 20 minutes of applying the sealant to the parting line area.

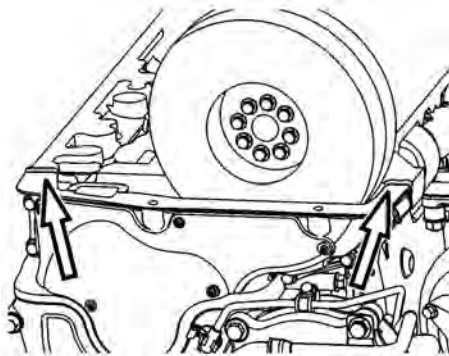

W2005157

- 45 Carefully position the valve cover on the cylinder head, making sure that the gasket remains properly seated.
- 46 Install the spring-loaded fasteners in the valve cover and tighten in sequence to 24 ± 3 Nm (18 ± 2 ft-lb).

Note: The fastener springs provide even tension on the valve cover gasket.

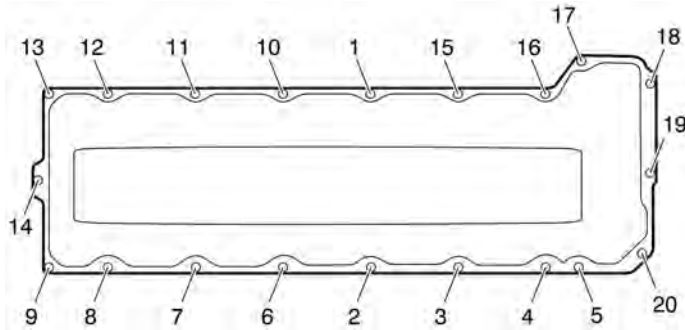

T2022732

- 47 Place the engine wiring harness and support bracket in position at the front of the valve cover and install the mounting screws to secure the bracket.

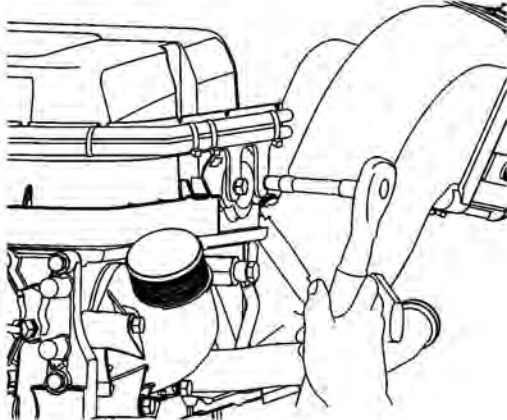

W2004679

- 48 Inspect the crankcase ventilation tube O-ring and replace if necessary. Lubricate the O-ring.
- 49 Position the crankcase ventilation tube onto the valve cover. Install the fasteners and tighten to 24 ± 3 Nm (18 ± 2 ft-lb). Install the clamp to secure the tube to the inlet manifold.
- 50 Connect the air compressor discharge line and tighten the fitting to 130 ± 20 Nm (96 ± 15 ft-lb). Install the clamp to secure the line to the bracket on the inlet manifold.

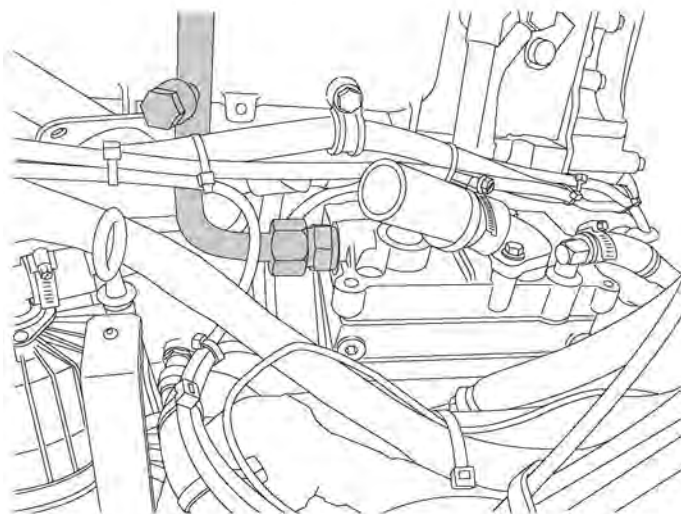

W5001572

- 51 Install all components removed to access the valve cover.
- 52 Install all previously removed cables to the ground (negative) battery terminals.
- 53 Start the engine. Check for proper operation and leaks.

Reimbursement

This repair is covered by an authorized Service Program. Reimbursement is obtained via the normal claim handling process.	UCHP Reimbursement	eWarranty Reimbursement
Claim Type (used only when uploading from the Dealer Bus. Sys.)	41	41
Recall Status		
Vehicle inspected, repair not required		1- Inspected OK
Vehicle repaired per instruction		2- Modified per instruction
Labor Code		
Primary Labor Code	2145-03-09-02 4.2 hrs	2131K-ZY-96 4.2 hrs.
Take to take charge and determine campaign status	1700-16-01-01 0.3 hrs	17003-0-01 0.3 hrs
Causal Part	21415409	21415409
Parts Disposition All parts to be scraped locally		
SCC Code	S6504	NA
Authorization Number	NA	PI0856
Expiration Date	1-July-2015	1-July-2015

Note: Take Charge Time is not included in the Labor Code for this operation. Take charge may be eligible but can only be used once per repair visit. If vehicle is having other warranty repairs performed, take charge should be charged to the warranty repair, otherwise take charge can be charged to this service program.