

# Front License Plate & Mounting Bracket Installation

Service  
Category General

Section Pre-Delivery Service

Market USA

Lexus Supports  
ASE Certification 

## Applicability

YEAR(S)	MODEL(S)	ADDITIONAL INFORMATION
2015	ES300H, ES350	

## Introduction

The front license plate mounting bracket and 2 self-tapping screws for the 2015 model year ES 350 and ES 300h are stored in the glove compartment of the vehicle. Install the license plate and mounting bracket during Pre-Delivery Service (PDS).

## Warranty Information

OP CODE	DESCRIPTION	TIME	OFF	T1	T2
N/A	Not Applicable to Warranty	-	-	-	-

## Front License Plate & Mounting Bracket Installation

### Installation Procedure

1. Align the center tab on the front license plate mounting bracket with the centerline of the air intake.

Figure 1.

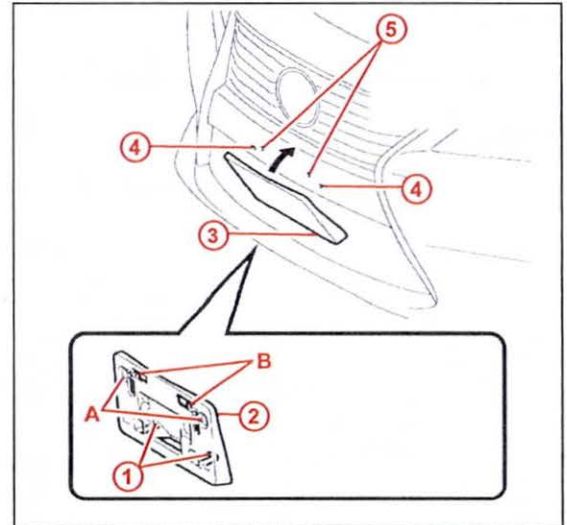

1	Hooks
2	Mounting Bracket
3	Rotate Bracket
4	Dimples
5	Mark and Drill Holes

2. Attach the hooks of the front license plate mounting bracket to the third air intake opening and rotate bracket upwards.
3. Align holes "A" of the mounting bracket with the dimples on the front bumper cover. Mark the location of holes "B" on the front bumper cover.

#### HINT

- Holes "A" are used to install the mounting bracket to the bumper cover.
- Holes "B" are used to install the front license plate to the mounting bracket.

## Front License Plate & Mounting Bracket Installation

### Installation Procedure (Continued)

- Drill 2 relief holes with a diameter of 11.0 mm (0.43 in.) at the marks on the front bumper cover (holes "B") to prevent the license plate retaining bolt ends from contacting the cover.

**NOTICE**

Do NOT drill into the dimples on the front bumper cover.

- Install the mounting bracket to the front bumper cover (holes "A") using the 2 supplied self-tapping screws.

**NOTE**

Be sure to tighten both the driver side and passenger side screws.

Figure 2.

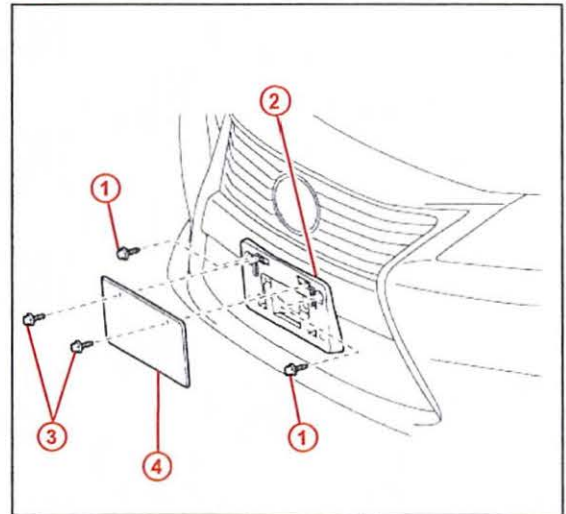

1	Self-tapping Screw
2	Mounting Bracket
3	Bolt
4	License Plate

- Install the front license plate to the mounting bracket using 2 non-corroding bolts with the following dimensions:

Nominal Length: 15.0 mm (0.59 in.)

Diameter: 6.0 mm (0.24 in.)

Figure 3.

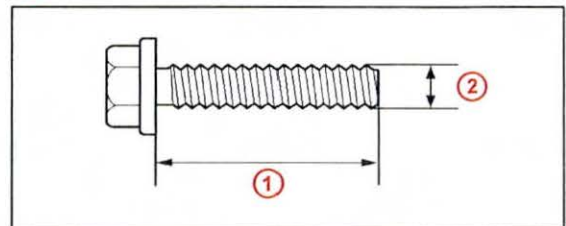

1	Nominal Length
2	Diameter