

DCC Fuse Installation During PDS

Service
Category General

Section Pre-Delivery Service

Market USA

Lexus Supports
ASE Certification 

Applicability

YEAR(S)	MODEL(S)	ADDITIONAL INFORMATION
2015	IS250C, IS350C	

Introduction

The DCC fuse (20A) has been removed at the assembly plant to reduce parasitic draw during transportation and storage. The DCC fuse is stored in the blank space of the Fuse Block in the engine compartment and must be installed in its original location during Pre-Delivery Service (PDS).

Warranty Information

OP CODE	DESCRIPTION	TIME	OFP	T1	T2
N/A	Not Applicable to Warranty	-	-	-	-

DCC Fuse Installation During PDS

Installation Procedure

Remove the DCC fuse (20A) from the blank space of the Fuse Block in the engine compartment and install it in its original location as shown.

Figure 1.

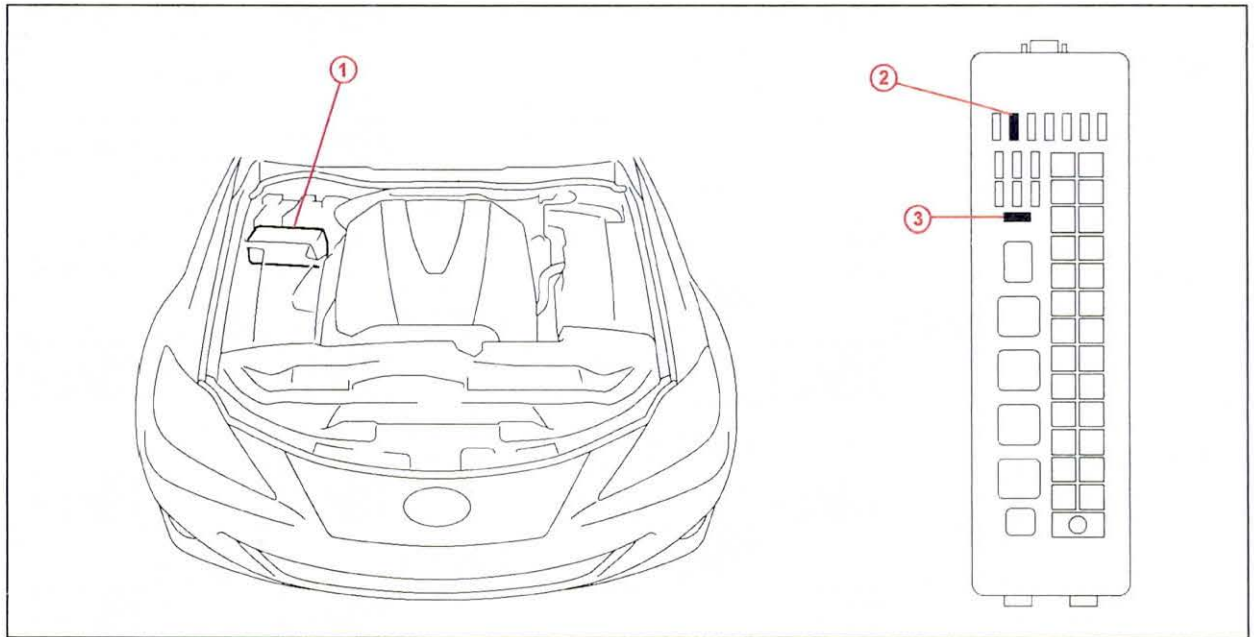

1	Fuse Block
2	Install DCC Fuse (20A) Here (Original Location)

3	DCC Fuse Storage Location
---	---------------------------

NOTE

- Removing the DCC fuse cuts off power sources relating to the DOME and MPX-B fuses.
- If the vehicle is stored at the dealership for a long period of time after PDS, disconnect the negative (-) battery terminal to prevent battery discharge. Refer to Service Bulletin No. [PG001-06](#), "Battery Maintenance for In-Stock Vehicles & Pre-Delivery," for battery maintenance information.