

# Tire Pressure Warning System Activation & Initialization

Service  
Category General

Section Pre-Delivery Service

Market USA

Lexus Supports  
ASE Certification 

## Applicability

YEAR(S)	MODEL(S)	ADDITIONAL INFORMATION
2015	GS350, GS450H	

## Introduction

2015 model year GS 350 and GS 450h vehicles are equipped with a direct-type Tire Pressure Warning System (TPWS). Each tire (except the spare tire) has a tire pressure warning valve/sensor that measures tire pressure. The data is transmitted to the Tire Pressure Warning System antenna/receiver and then to the Tire Pressure Warning System ECU.

During Pre-Delivery Service (PDS), the tire pressure warning valves/sensors must be activated and the system initialized according to the procedure in this bulletin.

## Required Tools & Equipment

REQUIRED EQUIPMENT	SUPPLIER	PART NUMBER	QTY
Techstream 2.0*	ADE	TS2UNIT	1
Techstream Lite		TSLITEPDLR01	

\* Essential SST.

### NOTE

- Only ONE of the Techstream units listed above is required.
- Software version 9.20.022 or later is required.
- Additional Techstream units may be ordered by calling Approved Dealer Equipment (ADE) at 1-800-368-6787.

## Warranty Information

OP CODE	DESCRIPTION	TIME	OFF	T1	T2
N/A	Not Applicable to Warranty	-	-	-	-

## Tire Pressure Warning System Activation & Initialization

### Reference

- After cycling the ignition to the "IG-ON" position, the Low Tire Pressure Warning Light will blink for 1 minute and remain illuminated until all the tire pressure warning valves/sensors are activated.
- The Diagnostic Trouble Codes (DTCs) listed below are stored in the TPWS ECU until the tire pressure warning valves/sensors are activated.
- The DTCs will automatically clear when the tire pressure warning valves/sensors are activated.

Figure 1.

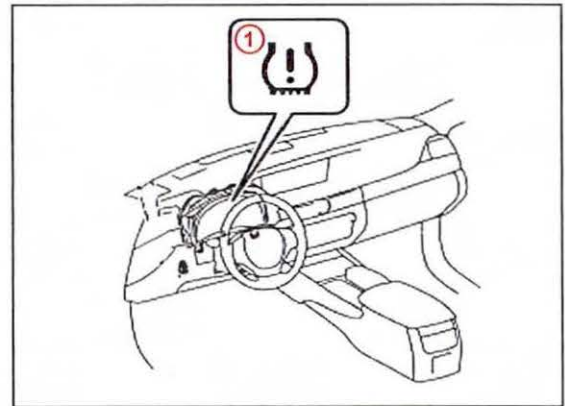

<b>1</b>	<b>Low Tire Pressure Warning Light</b>
----------	--

DTC *1	DTC *2	DTC EXPLANATION
11	C2111	Transmitter ID1 Inactive
12	C2112	Transmitter ID2 Inactive
13	C2113	Transmitter ID3 Inactive
14	C2114	Transmitter ID4 Inactive

\*1: Indicated by flashing of the Low Tire Pressure Warning Light.

\*2: Indicated on Techstream.

## Tire Pressure Warning System Activation & Initialization

### Activation Procedure

1. Connect Techstream.
2. Cycle the ignition switch to the "IG-ON" position and check that the Low Tire Pressure Warning Light blinks for 1 minute and then remains illuminated.

Figure 2.

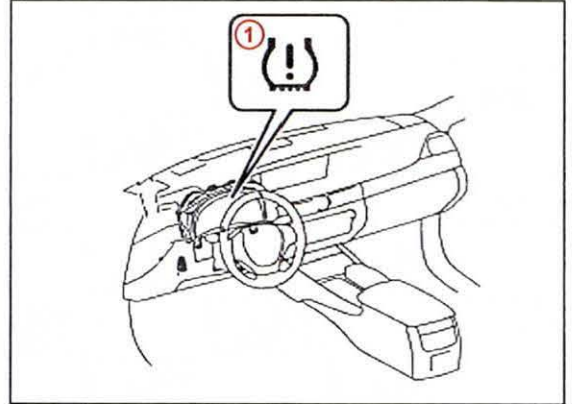

1 Low Tire Pressure Warning Light

3. Press or remove the valve core to reduce the tire inflation pressure rapidly by 6 psi (0.4 kgf/cm<sup>2</sup>, 40 kPa), or more, within 30 seconds. If the tire inflation pressure is NOT reduced by 6 psi (0.4 kgf/cm<sup>2</sup>, 40 kPa), or more, within 30 seconds, the tire pressure warning valves/sensors will NOT be activated.

Figure 3.

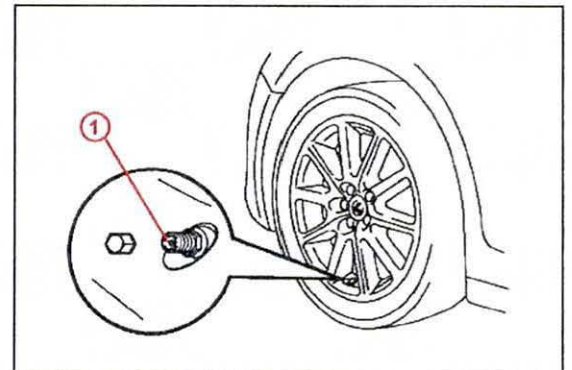

1 Core

**NOTE**

This operation is required for the system to be activated and must be performed for each tire (except the spare tire), one at a time.

## Tire Pressure Warning System Activation & Initialization

### Activation Procedure (Continued)

4. Using Techstream, check for TPWS DTCs.
  - If NO DTCs are stored, go to step 1 of the Initialization Procedure.
  - If DTCs C2111 – C2114 are stored, repeat step 3.

**HINT**

If the tire inflation pressure is NOT reduced by 6 psi (0.4 kgf/cm<sup>2</sup>, 40 kPa), or more, within 30 seconds, the tire pressure warning valves/sensors will NOT be activated and DTCs C2111 – C2114 will be stored in the TPWS ECU.

**NOTE**

If DTCs C2111 – C2114 are present after repeating step 3, lift the vehicle and turn each tire 90 to 270 degrees. Then repeat steps 3 – 4.

### Initialization Procedure

1. Cycle the ignition switch to the "IG-ON" position and connect Techstream.
2. Adjust all tires (except the spare tire) to the standard tire inflation pressure, as indicated on the Tire and Loading Information label located inside the vehicle and confirm that the Low Tire Pressure Warning Light is OFF.

**NOTE**

- To adjust tire pressure correctly when outside temperature is significantly colder than shop temperature, perform a Health Check using Techstream and select the "Compensation Tire Pressure" checkbox. Compensation pressures will be displayed on the health check results screen.
- Adjust the tire pressure when the tires are cold.

Figure 4.

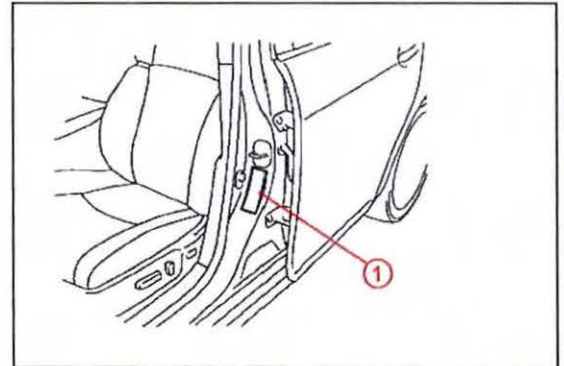

1 | Tire and Loading Information Label

## Tire Pressure Warning System Activation & Initialization

### Initialization Procedure (Continued)

3. Push and hold the Tire Pressure Warning "SET" Switch for 3 seconds until the Low Tire Pressure Warning Light blinks 3 times and then turns OFF to set the tire pressure initialization.

**NOTE**

It is necessary for the ignition to be in the "IG-ON" position AT LEAST 5 minutes for initialization to complete correctly.

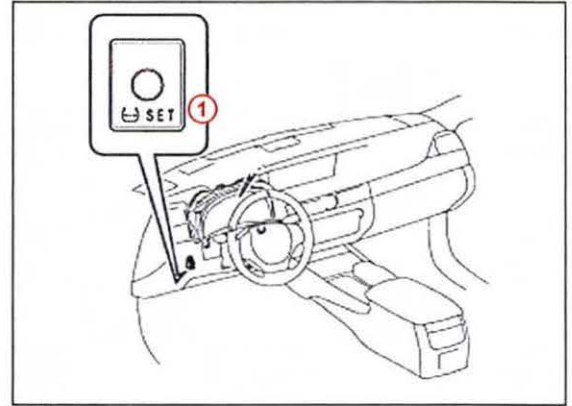
**Figure 5.**

1	Tire Pressure Warning "SET" Switch
---	------------------------------------

4. Cycle the ignition "OFF" and then to "IG-ON".
5. Check the tire pressure values of all the tires using Techstream.

### Chassis/Tire Pressure Monitor/Data List

**NOTE**

It can take 2 – 3 minutes for the tire pressure values to be displayed on the Techstream Data List.