

© 2013 Mazda Motor of America, Inc.

<b>Subject:</b> <b>UNABLE TO LOWER REAR SEATBACK WITH REMOTE HANDLE / SEATS HARD TO LOCK</b>	<b>Bulletin No:</b> 09-013/13
	<b>Last Issued:</b> 10/24/2013

## BULLETIN NOTE

- This bulletin supersedes the previous bulletin 09-013/13 issued 04/29/13 and 09-042/12 issued 11/07/12. The APPLICABLE MODEL(S)/VINS, DESCRIPTION, REPAIR PROCEDURE, PART(S) and WARRANTY INFORMATION have been revised.
- Changes are noted below in Red beside the change bar.

## APPLICABLE MODEL(S)/VINS

2013-2014 CX-5 vehicles equipped with a 4:2:4 split type rear seat

## DESCRIPTION

Some vehicles equipped with a 4:2:4 split type rear seat may be unable to lower the rear seatback (A) when pulling the left (B) and/or right (C) remote handles. Also, the seatbacks may not fully latch (lock) when placed in the upright position.

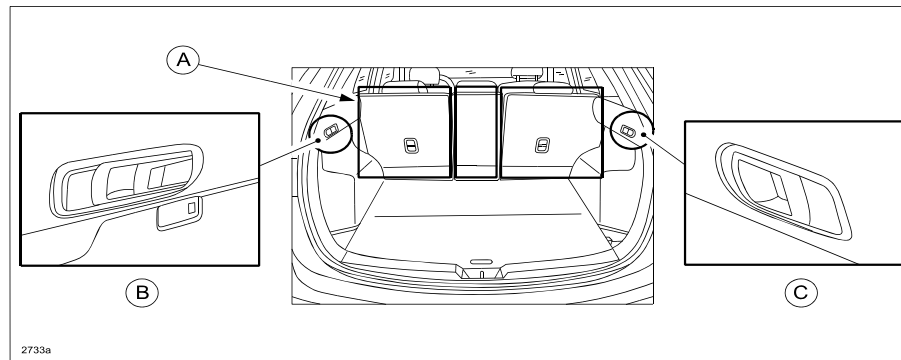

This concern may be caused by either of the following:

- Insufficient remote cable tension due to incorrect adjustment position (A) of the remote cable.
- The cable ball (B) gets seized on sharp edges inside the cylinder.

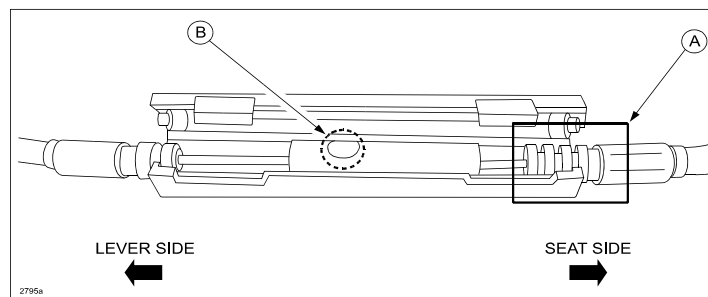

Customers with this concern should have their vehicle repaired according to the following repair information.

Page 1 of 4

**CONSUMER NOTICE:** The information and instructions in this bulletin are intended for use by skilled technicians. Mazda technicians utilize the proper tools/equipment and take training to correctly and safely maintain Mazda vehicles. These instructions should not be performed by "do-it-yourselfers." Customers should not assume this bulletin applies to their vehicle or that their vehicle will develop the described concern. To determine if the information applies, customers should contact their nearest authorized Mazda dealership. Mazda North American Operations reserves the right to alter the specifications and contents of this bulletin without obligation or advance notice. All rights reserved. No part of this bulletin may be reproduced in any form or by any means, electronic or mechanical---including photocopying and recording and the use of any kind of information storage and retrieval system ---without permission in writing.

## REPAIR PROCEDURE

**NOTE:** This repair only applies to vehicles equipped with a 4:2:4 split type rear seat.

1. Verify the customer concern.
2. Lower the rear seatbacks using the seatback knobs.

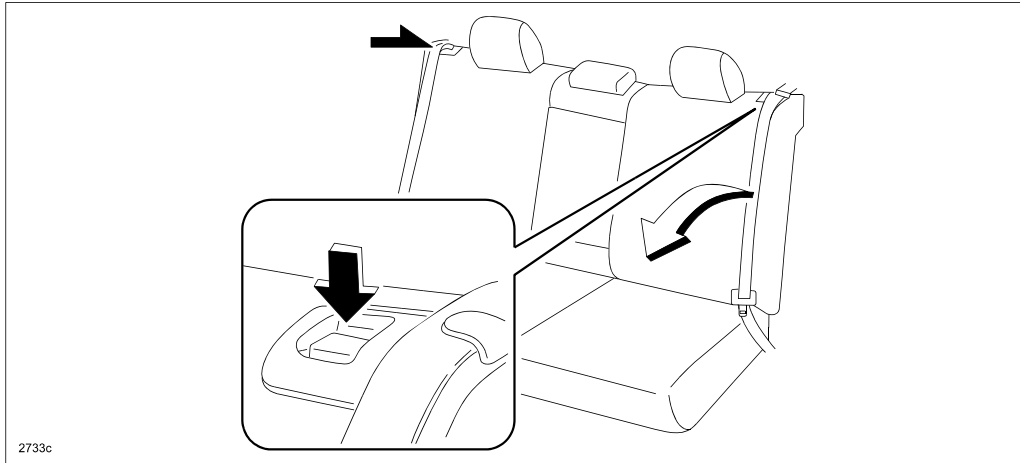

3. Replace the remote handle lever assembly (including the remote cable) according to the online MS3 instruction or the Workshop Manual (section 09-13 REMOTE HANDLE LEVER REMOVAL/INSTALLATION).

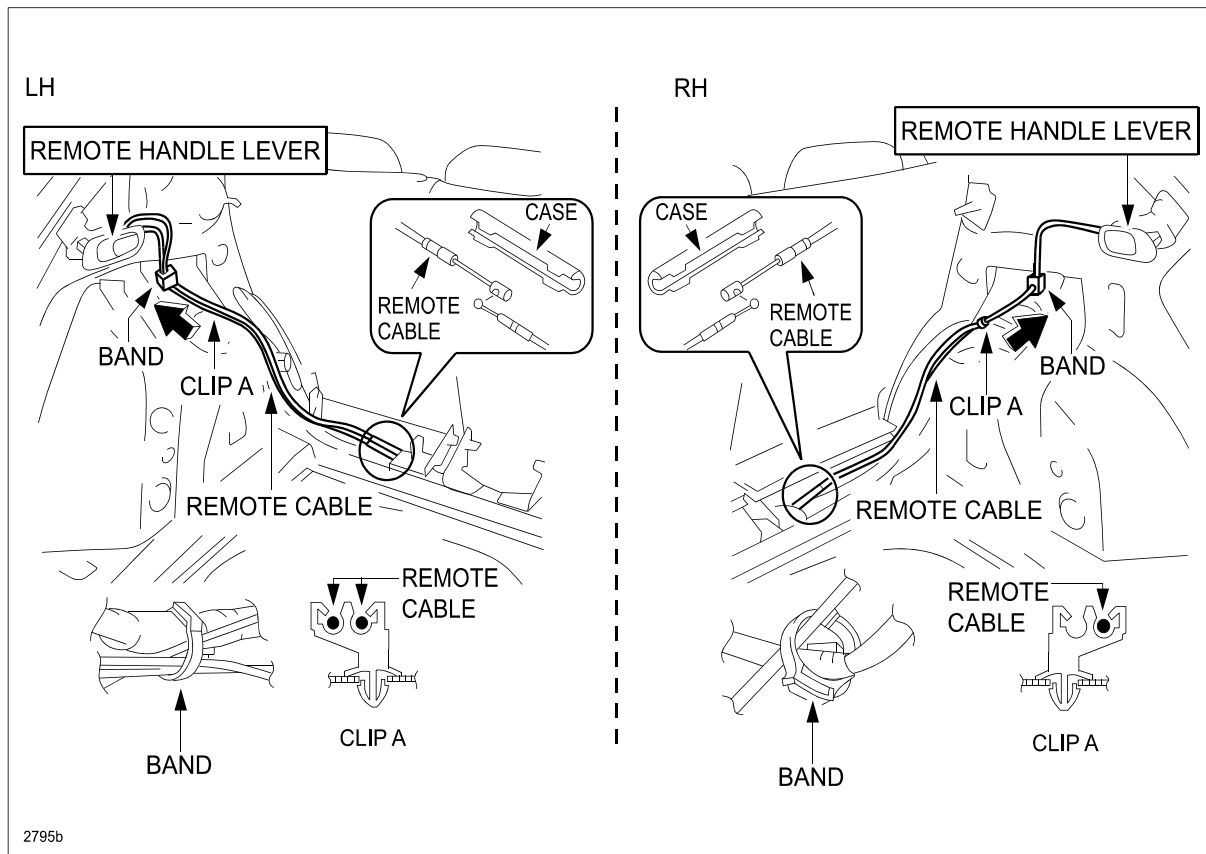

4. Set the adjustment groove to the position where the malfunction does not occur according to the online MS3 instruction or the Workshop Manual (section 09-13 REAR SEAT REMOVAL/INSTALLATION - Remote Cable Adjustment Procedure).

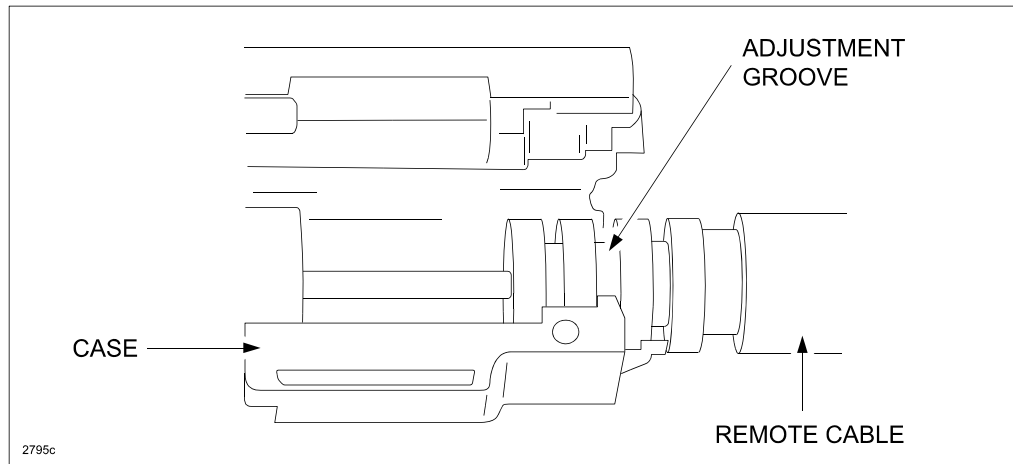

5. Verify the repair by pulling the appropriate remote handle lever to check the seat back for proper releasing and locking operation.

**NOTE:** The red seat knob indicator must be visible when the seat back is in the unlocked position (seat knob down) and must not be visible when the seat is fully locked (seat knob up).

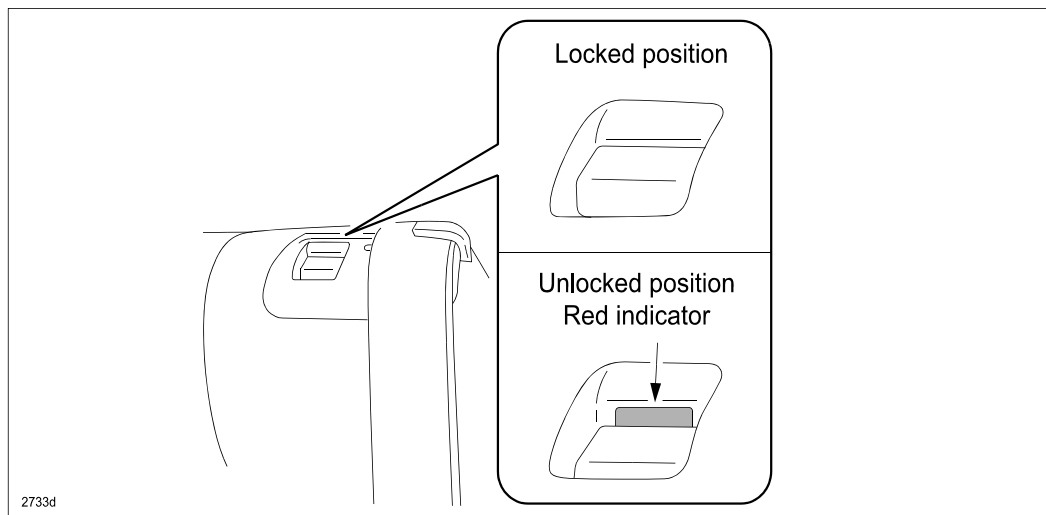

## PART(S) INFORMATION

Part Number	Description	Qty.
KD49-57-X5XE-02	Remote handle lever assembly (RH)	1
KD49-57-X5YE-02	Remote handle lever assembly (LH)	1

## WARRANTY INFORMATION

**NOTE:**

- This warranty information applies only to verified customer complaints on vehicles eligible for warranty repair.
- This repair will be covered under Mazda's New Vehicle Limited Warranty term.
- Additional diagnostic time cannot be claimed for this repair.

Warranty Type	A
Symptom Code	41
Damage Code	9H
Part Number Main Cause	KD49-57-X5XE-02 or KD49-57-X5YE-02
Quantity	1
Operation Number / Labor Hours:	XXJA7XRX / 0.4 Hrs. (One side) XXJA8XRX / 0.5 Hrs. (Both sides)

**NOTE:** This repair only applies to vehicles equipped with a 4:2:4 split type rear seat.