

Subject: EXCESSIVE OPERATING NOISE WHEN SLIDING POWER SEAT	Bulletin No: 09-021/13
	Last Issued: 07/19/2013

APPLICABLE MODEL(S)/VINS

2014 Mazda6 equipped with power seats with VINs lower than JM1GJ*****125980 (produced June 1, 2013)

DESCRIPTION

Some vehicles may exhibit excessive noise when operating either front power seat forward or backward.

The noise may be caused by cable vibration, which transmits power from the motor to the gears. The cable vibrates inside the case due to inadequate fabric wrapped around the cable. The fabric thickness has been increased to eliminate the noise.

Customers having this concern should have their vehicle repaired using the following repair procedure.

REPAIR PROCEDURE

1. Verify if the noise is coming from the driver and/or passenger side seat when sliding the seat back and forth with the slide switch.

NOTE:

- To show the cable layout more clearly, the seat cushion was removed for the illustrations in this bulletin.
- Replace the power seat cable (with a modified part) only for the seat(s) generating noise.

WARNING: Be sure to wear work gloves to avoid injuries by the seat frame.

2. Fold the seat back forward by operating the reclining switch.
3. Adjust the seat height and tilt positions upward by operating the switches in order to increase work space as necessary.

NOTE: There is no tilt or height adjustment function on the passenger side power seat.

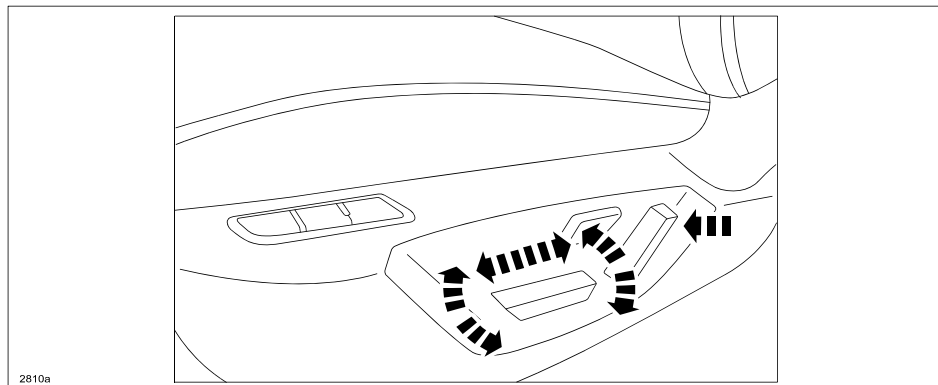

4. Slide the seat forward, then remove the rear installation bolts.
NOTE: Remove the rear installation bolts before removing the front installation bolts.
5. Slide the seat rearward, then remove the front installation bolts.
6. Lay the seat back down with care to avoid damaging the surrounding parts.

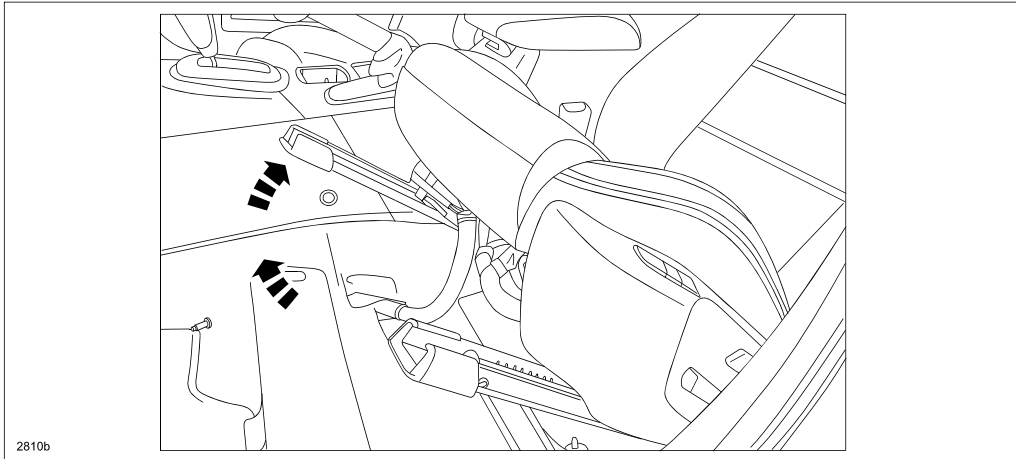

7. Insert an appropriate tool between the frame and the cable (the general area is shown below/left). Use the tool as a lever to release the cable from the center bracket (50mm from the motor as shown below/right).

CAUTION: To avoid adjuster unit damage, DO NOT operate the slide switch after removing the cable.

NOTE: To show the cable layout more clearly, the seat cushion is not shown.

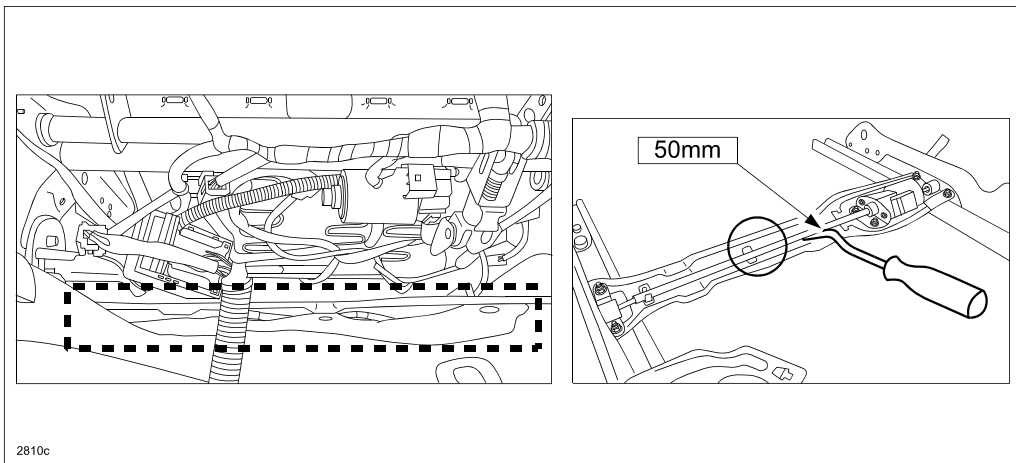

8. Hold the cable by hand and lift it up to release it from the (2) two outer cable brackets.

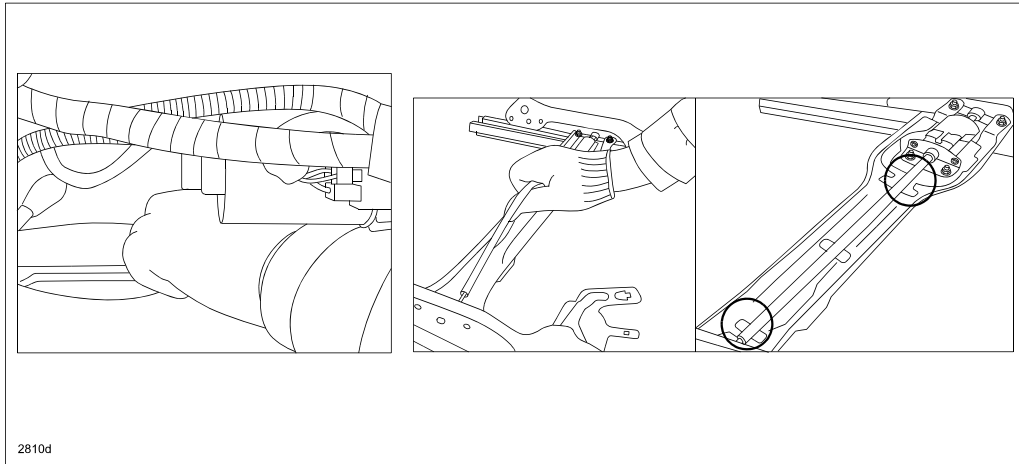

9. Pull the cable in the direction of the arrow (as shown below) to remove it from the motor.

CAUTION: When removing the cable, remove it from the motor side first. If it is removed from the gear box side first, the engagement position could become misaligned.

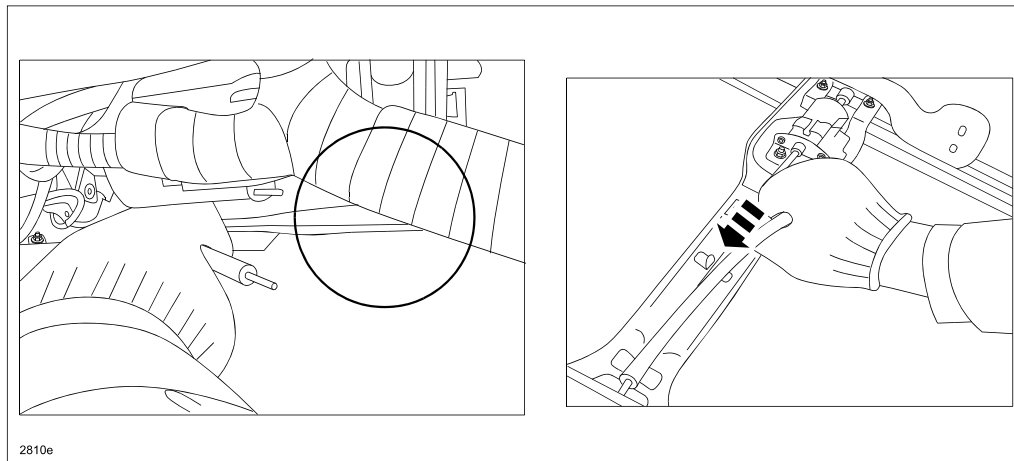

10. Pull the cable in the direction of the arrow (shown below) to remove it from the gear box.

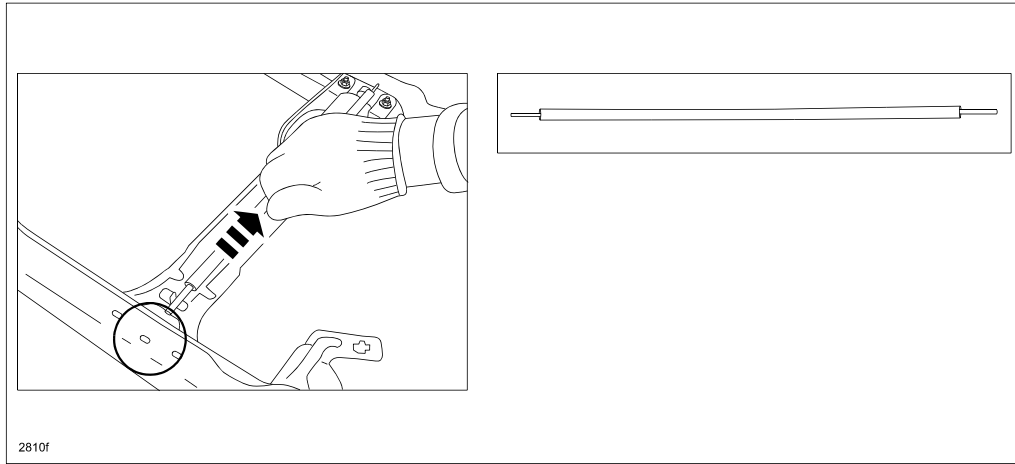

11. Align the square tip of the new cable to the square shape in the motor. Push the cable all the way in (A) using care not to damage or deform it.

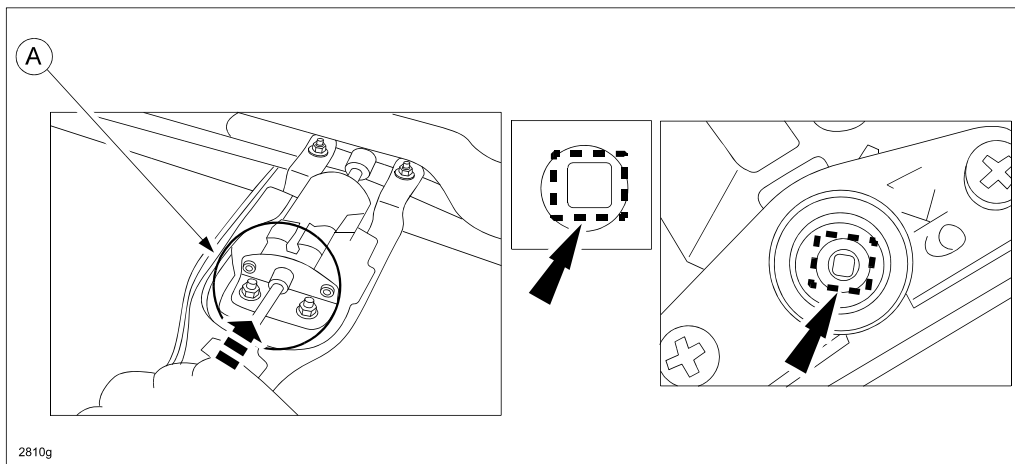

12. Align the square tip of the cable to the square shape in the gear box. Push the cable all the way in.

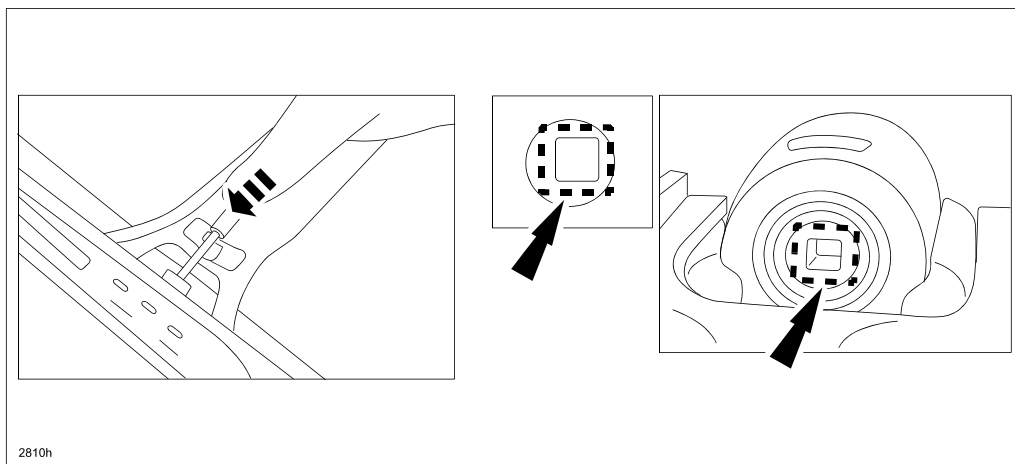

CAUTION:

- If the cable is bent too much during installation, operation noise may occur. **DO NOT** hold the cable around the tip.

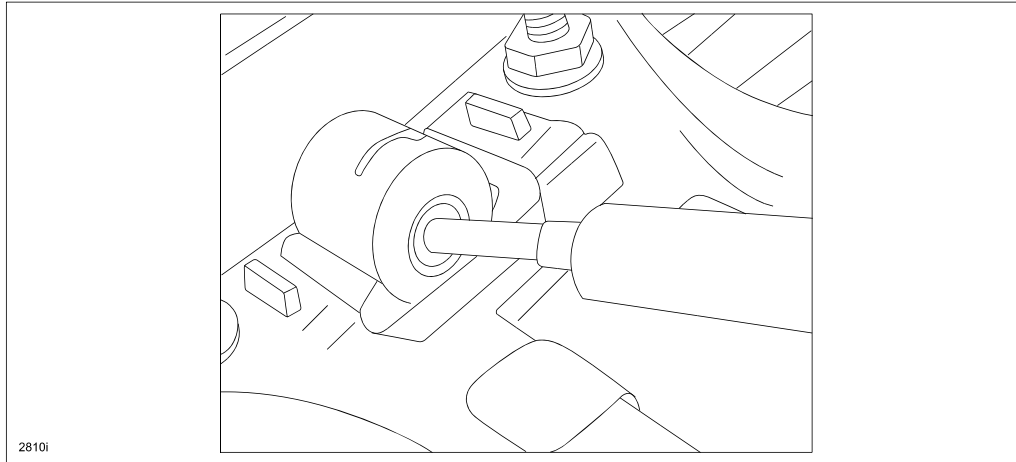

CAUTION:

- If work space is too dark to see properly, use a light to illuminate the spot where the cable should be installed.
- Take caution not to pinch the seat belt buckle harness (A).

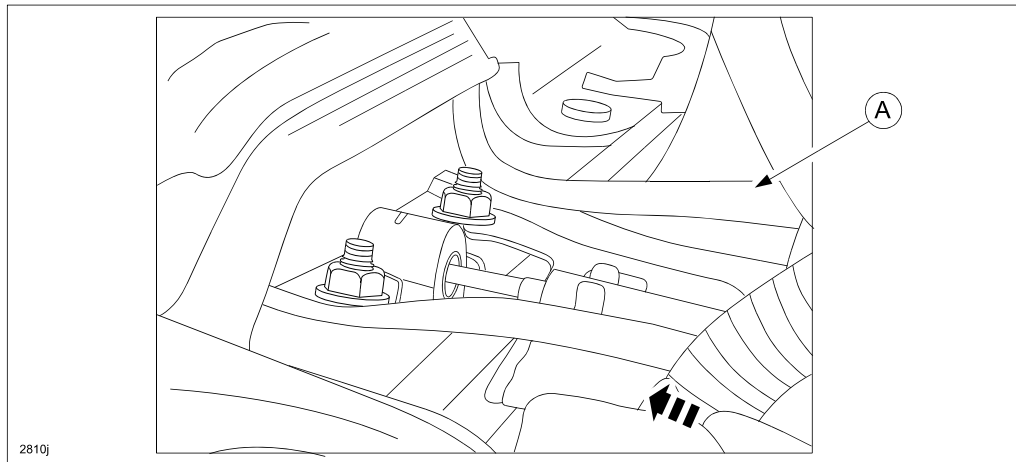

13. Press the cable from above with your fingers to secure it in the (3) three brackets shown below.

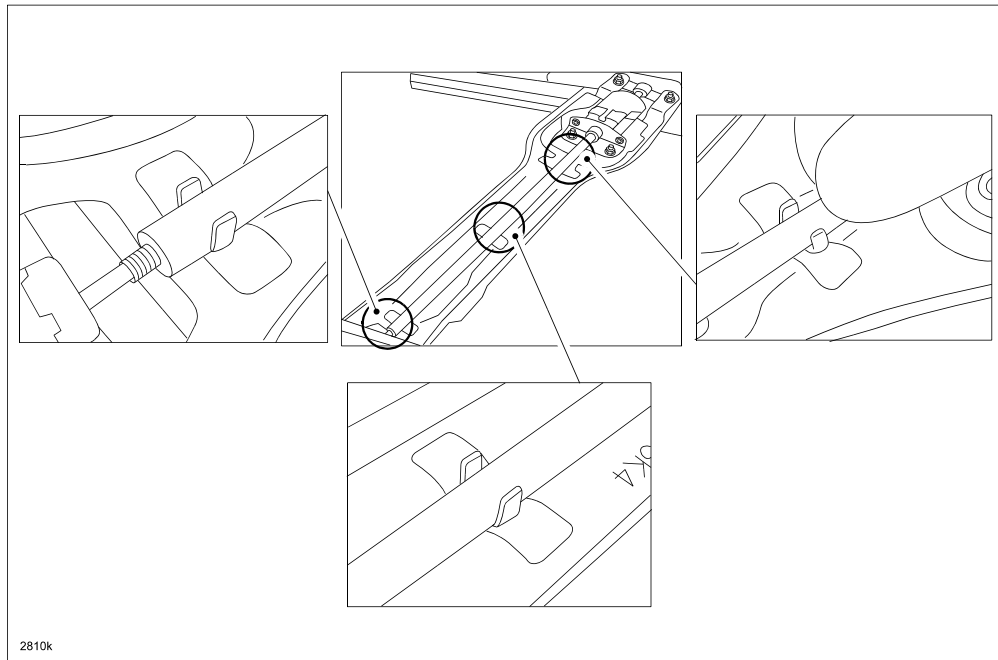

14. Look under the seat and verify the following points:

- The cable is not curved or floating.
- The cable is properly installed into the motor side and gear box side (A).
- The cable is properly secured to the seat frame at each cable bracket (B).

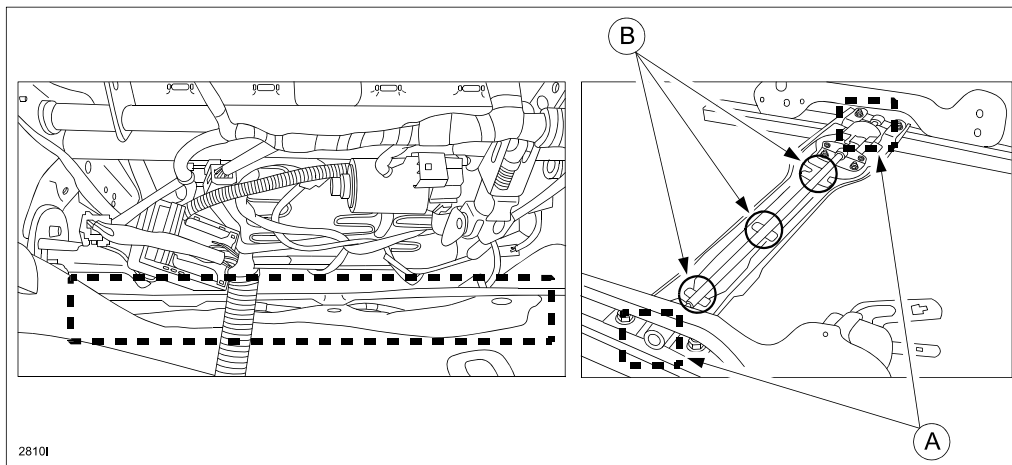

15. Reinstall the seat in reverse order of removal.

16. Verify the seat slides back and forth without any problem and that the noise is gone.

NOTE: If the cable is not installed correctly, the following abnormal conditions could occur:

- The seat slides only on one side rail (left or right side only).
- A rasping type noise is heard.

17. SEAT WITH SEAT WEIGHT SENSOR ONLY: Perform the seat weight sensor inspection according to the instructions on MS3 online or the Workshop Manual (section 09-13 [SEATWEIGHT SENSOR REMOVAL/ INSTALLATION [TWO-STEP DEPLOYMENT CONTROL SYSTEM]]).

18. Verify the repair.

Bulletin No: 09-021/13
© 2013 Mazda Motor of America, Inc.

Last Issued: 07/19/2013

PART(S) INFORMATION

Part Number	Description	Qty.	Notes
GHL2-88-0D1	Power seat cable	1 or 2	1 cable per side

WARRANTY INFORMATION

NOTE:

- This warranty information applies only to verified customer complaints on vehicles eligible for warranty repair.
- This repair will be covered under Mazda's New Vehicle Limited Warranty term.
- Additional diagnostic time cannot be claimed for this repair.

Warranty Type	A
Symptom Code	80
Damage Code	97
Part Number Main Cause	GHL2-88-0D1
Quantity	1 or 2
Operation Number / Labor Hours:	XXJ8TXRX / 0.3 Hrs: One side (with or w/o seat weight sensor) XXJ8UXRX / 0.4 Hrs: Both sides (w/o seat weight sensor) XXJ8VXRX / 0.5 Hrs: Both sides (with seat weight sensor)