

| | |
|--|--------------------------------|
| Subject: i-ELOOP BATTERY SERVICE INFORMATION | Bulletin No: 01-016/13 |
| | Last Issued: 06/19/2013 |

APPLICABLE MODEL(S)/VINS

2014 Mazda6 vehicles equipped with i-ELOOP

DESCRIPTION

This service information provides basic Q85/T110 battery handling procedures. Complete service information can be found in MS3 online or Workshop Manual (section 01-17).

NOTE: The GR8 Battery Management System Q85/T110 software is currently under development. Use the GR8 Battery Management System, Manual Mode Battery Charging procedure in this bulletin to charge the Q85/T110 battery at this time. This bulletin will be revised when the new software is available.

Q85/T110 BATTERY MAINTENANCE

- Maintain battery charge during vehicle storage.
 - Charge the battery regularly even though there's no electrical load applied.
 - If battery is left discharged for long periods, battery failure may occur.
- Maintain battery charge during parts inventory.
 - Charge the battery regularly during parts stock.
 - If battery is left discharged for long periods, battery failure may occur.

Q85/T110 BATTERY INSPECTION

- Voltage measurement.
 - Battery voltage can only be measured on a battery that has not been recently charged.
 - If the battery was recently charged, wait 6 hours or more before checking the battery voltage.
 - Is the battery voltage 12.4 volts or higher?
Yes - The battery is charged.
No - Proceed to Q85/T110 BATTERY CHARGING.
- Specific gravity measurement.

This is the preferred method for battery inspection because battery condition can be ascertained.

 - Mix the electrolyte solution on all 6 cells by using a siphon to suction the electrolyte from the battery and then put it back in.
 - Use a scope type specific gravity battery meter (refractometer) to measure all six cells. If your dealer does not have the required tool, proceed to REFRACTOMETER SPECIAL SERVICE TOOL (SST) LOANER REQUEST.
 - Is the cell with lowest electrolyte specific gravity 1.25 or more?
Yes - The battery is fully charged.
No - Go to step d.
 - Is the cell with lowest electrolyte specific gravity less than 1.17?
Yes - Replace the battery.
No - Proceed to Q85/T110 BATTERY CHARGING.

Q85/T110 BATTERY CHARGING

1. Remove the battery from the vehicle.

CAUTION: Do not charge the battery in the vehicle. Vehicle electrical system damage may occur.

2. Remove the battery filler caps.
3. Adjust battery fluid level if needed using distilled water.
4. Mix the electrolyte solution on all 6 cells by using a siphon to suction the electrolyte from the battery and then put it back in.
5. Use a scope type specific gravity battery meter (refractometer) to measure all six cells. Record all 6 cell refractometer measurements in the repair order. If your dealer does not have the required tool, proceed to REFRACTOMETER SPECIAL SERVICE TOOL (SST) LOANER REQUEST.
6. Connect the GR8 Battery Management System to the battery.
7. Use the table below to determine the battery charge time.

Battery Charge Time Table

| Cell with lowest electrolyte specific gravity | 1.24 or more | 1.23 | 1.22 | 1.21 | 1.20 | 1.19 | 1.18 | 1.17 | 1.16 or less |
|---|--------------|------|------|------|------|------|------|------|-----------------|
| Charge Time (minutes) | 180 | 200 | 220 | 240 | 270 | 290 | 330 | 360 | Replace Battery |

8. From the MAIN MENU, select "Manual".

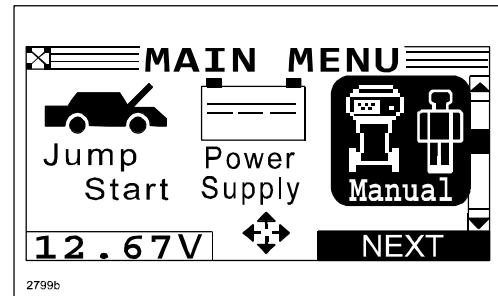

9. From the BATTERY TYPE MENU, select "REGULAR LEAD ACID".

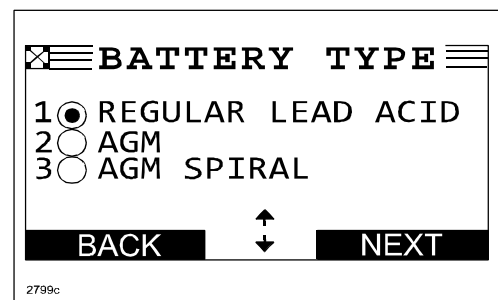

10. From the LIMIT TYPE MENU, select "LIMIT CURRENT".

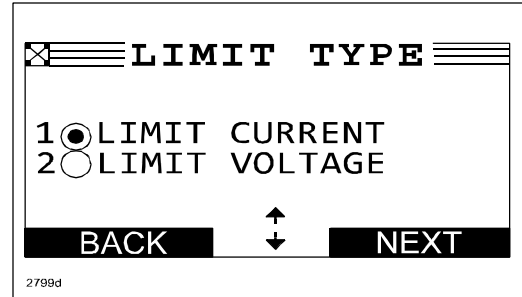

11. From the MAX CURRENT MENU, select "15 AMPS".

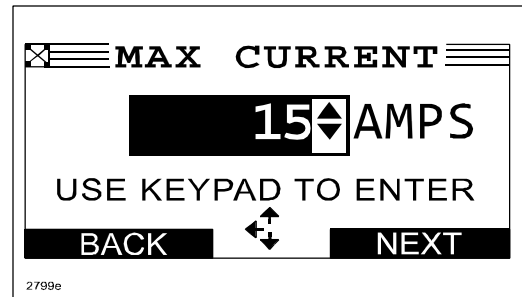

12. From the CHARGE TIME MENU, select "120 MIN".

NOTE: The GR8 Battery Management System can only charge a maximum of 120 minutes in Manual Mode. Repeat the Manual Mode charging process until the minutes required (per step 7.) to charge the battery have elapsed.

CAUTION: Do not use "CONTINUOUS" charge time mode. Battery damage may occur from overheating.

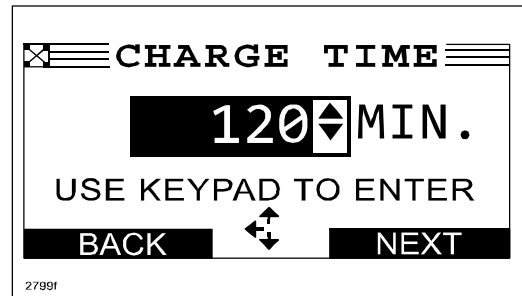

13. After completing the charge time, measure the electrolyte specific gravity of all six cells.
Is the cell with lowest electrolyte specific gravity 1.25 or more?
- Yes - The battery is fully charged and ready to be installed into the vehicle.
 - No - Replace the battery.

REFRACTOMETER SPECIAL SERVICE TOOL (SST) LOANER REQUEST

The refractometer SST is required for battery specific gravity measurement. Only order if needed.

1. Request a "Loaner" tool on MStore to perform battery specific gravity measurement. Order part number 75240-L. The tool will arrive next business day if the order is placed before 2pm PST.
2. When tool arrives, proceed to Q85/T110 BATTERY INSPECTION and/or Q85/T110 BATTERY CHARGING.
3. Clean and repack SST Refractometer and send back to Mazda - Special Tools Loaner Program using the supplied return label. The dealer will not be charged shipping cost.

NOTE: Dealer will be responsible for full replacement value if not returned or not returned in the same condition within 1 business day after the Q85/T110 BATTERY INSPECTION and/or Q85/T110 BATTERY CHARGING procedure is completed. Full cost = \$53.90.

Q85/T110 BATTERY JUMP START

If a jump start is necessary, do not remove the jumper cables or drive the vehicle until the instrument cluster Multi-Information Display warning message "i-ELOOP charging" is no longer displayed. This process takes about 3 minutes to complete.

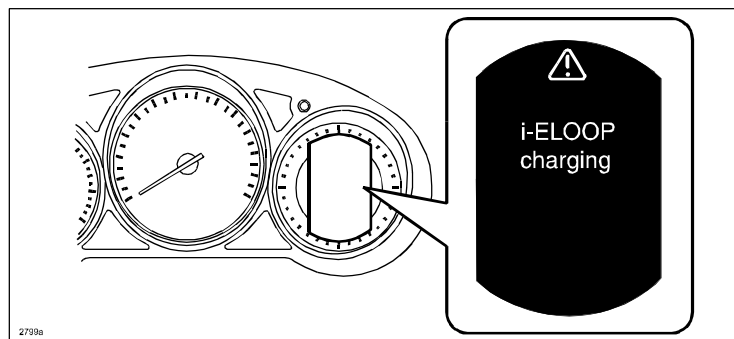

Q85/T110 NEGATIVE BATTERY CABLE DISCONNECT

1. Switch the ignition off.
2. Disconnect the current sensor connector (A) from the current sensor (B).
3. Disconnect the negative battery cable terminal (C).

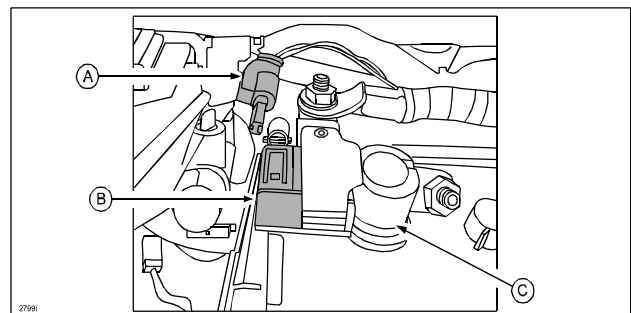

Q85/T110 NEGATIVE BATTERY CABLE CONNECTION

1. Connect the negative battery cable terminal (C).
2. Connect the current sensor connector (A) to the current sensor (B).

SPECIAL SERVICE TOOL (SST) INFORMATION

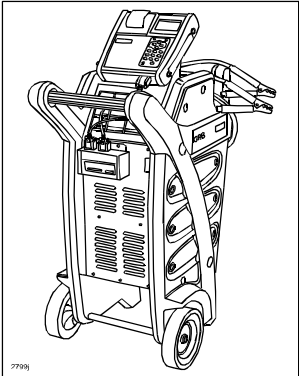
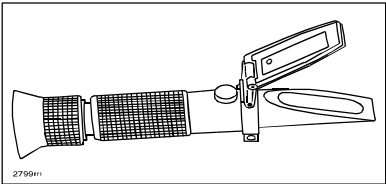
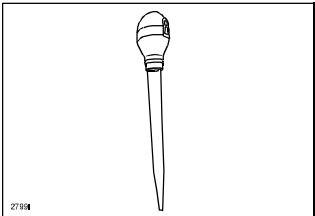
| Part Number | Description | Qty. | Image |
|-----------------|---|------|---|
| MTRGR81291KT | Battery Management System | 1 |  |
| 75240-L | Scope type specific gravity battery meter (Refractometer) | 1 |  |
| Locally sourced | Siphon | 1 |  |