

© 2013 Mazda Motor of America, Inc.

Subject: REAR MOUNT CAMERA DOES NOT OPERATE	Bulletin No: 09-016/13
	Last Issued: 05/07/2013

APPLICABLE MODEL(S)/VINS

2013 CX-5 with VINs lower than JM3KE*****155008 (produced before October 7, 2012)

DESCRIPTION

Some vehicles may exhibit an inoperative rear mount camera. This concern may be caused by water entering inside the camera during a high-pressure car wash.

The shape of the camera has been changed to eliminate this concern.

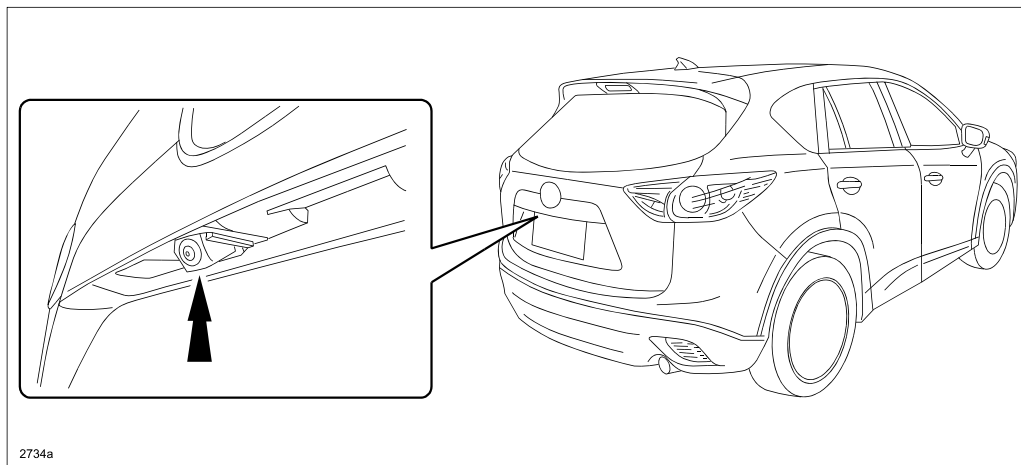

Customers having this concern should have their vehicle repaired using the following repair procedure.

REPAIR PROCEDURE

1. Verify the customer concern.
2. Inspect the rear mount camera according to the instructions on MS3 online or the Workshop Manual (section 09-20 REAR MOUNT CAMERA INSPECTION).
3. If the rear mount camera is found to be faulty, replace it with a modified one according to the instructions on MS3 online or the Workshop Manual (section 09-20 REAR MOUNT CAMERA REMOVAL/INSTALLATION).
4. Locate the opener switch connector (A).

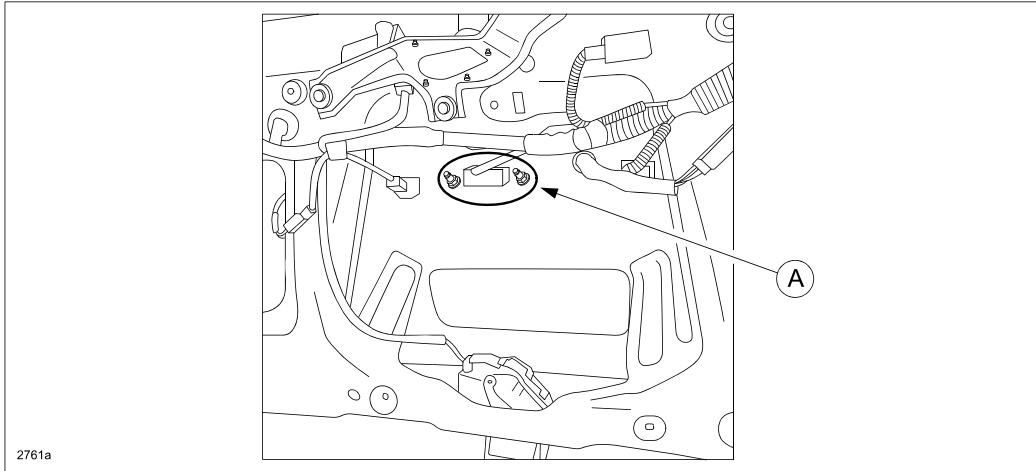

5. Attach a water-proof sheet over the opener switch connector as shown below.

NOTE: Be sure to attach a water-proof sheet, even if the vehicle did not originally have one installed.

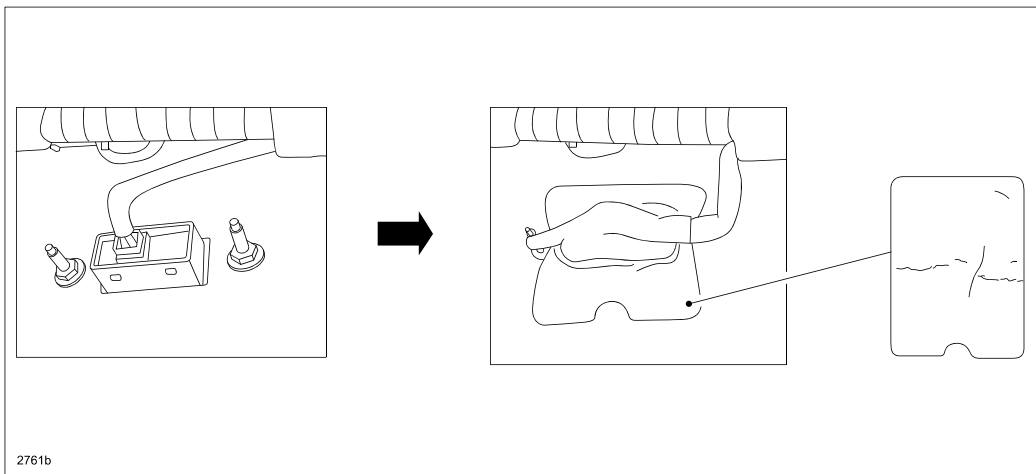

6. Verify the repair.

PART(S) INFORMATION

Part Number	Description	Qty.
KD33-67-RC0B	Rear Mount Camera	1
BC1B-58-862	Water-proof sheet	1

WARRANTY INFORMATION

NOTE:

- This warranty information applies only to verified customer complaints on vehicles eligible for warranty repair.
- This repair will be covered under Mazda's New Vehicle Limited Warranty term.
- Additional diagnostic time cannot be claimed for this repair.

Warranty Type	A
Symptom Code	61
Damage Code	9K
Part Number Main Cause	KD33-67-RC0B
Quantity	1
Operation Number / Labor Hours:	XXJ6GXRX / 0.5 Hrs.