

© 2013 Mazda Motor of America, Inc.

Subject: CLICKING NOISE WHEN OPENING TRUNK LID	Bulletin No: 09-006/13
	Last Issued: 03/28/2013

BULLETIN NOTE

- This bulletin supersedes the previous bulletin 09-006/13, issued on 03/13/2013. The WARRANTY INFORMATION has been revised.
- Changes are noted below in Red beside the change bar.

APPLICABLE MODEL(S)/VINS

2014 Mazda6 vehicles with VINs lower than JM1 GJ ***** 109003 (produced before February 01, 2013)

DESCRIPTION

Some vehicles may exhibit a clicking type noise when the trunk lid is fully opened or just before the fully open position. The twisting motion of the trunk lid balance springs (A) may cause the clip fixing the balance springs to move and scrape against the rear package tray panel.

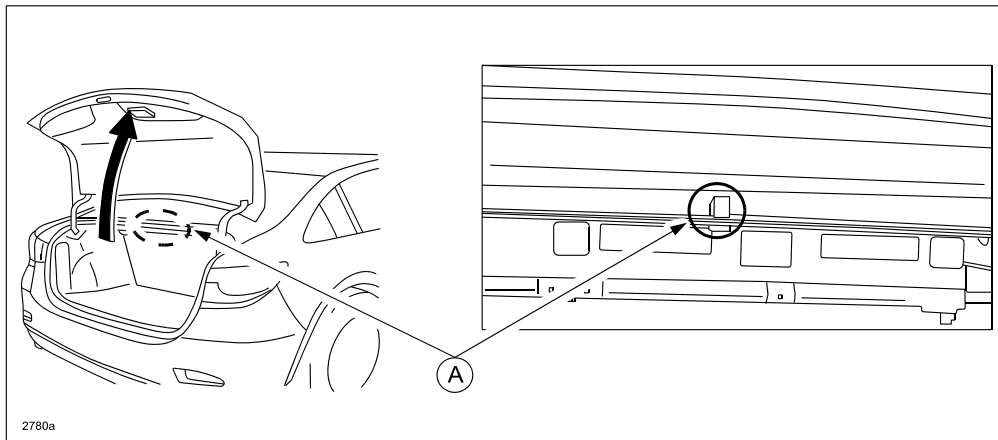

Customers having this concern should have their vehicle repaired using the following repair procedure.

REPAIR PROCEDURE

Attach non-woven fabric sheets between the clip and the rear package tray panel to prevent the noise.

1. Verify customer concern.
2. Select a sheet of non-woven fabric (0.25mm thickness) from the "Noise Parts Set" (TA01-76-100) and cut two 7mm x 20mm pieces.

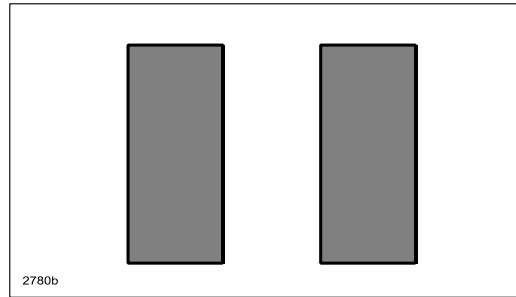

3. Open the trunk lid.
4. Pull down clip (A) by hand in the direction of the arrow as shown below.

NOTE: Make a space (C) between the clip (A) and the rear package tray panel (B).

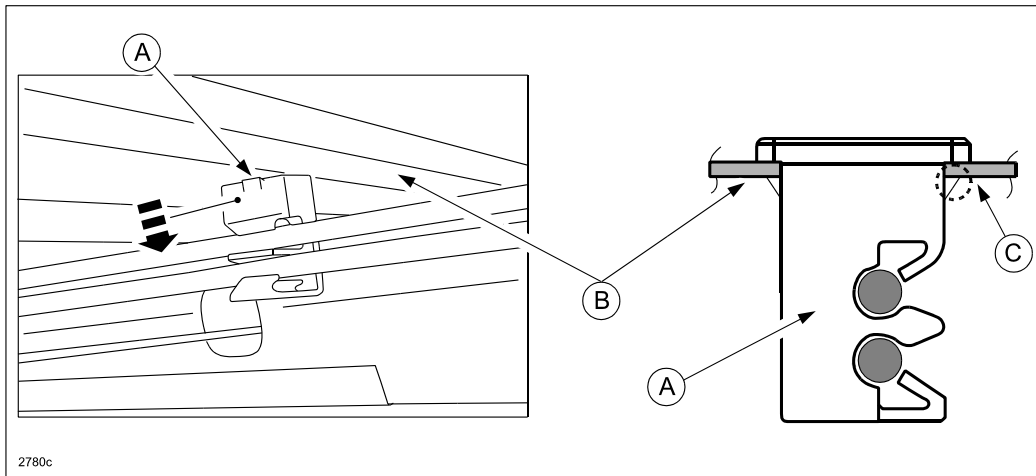

5. Stack the two non-woven fabric sheets together (total 0.5mm thickness) (D) and then insert them in space (C) between the clip and the rear package tray panel (B).

NOTE: If it is difficult to insert the sheets by hand, use a flat-blade screwdriver to push it in.

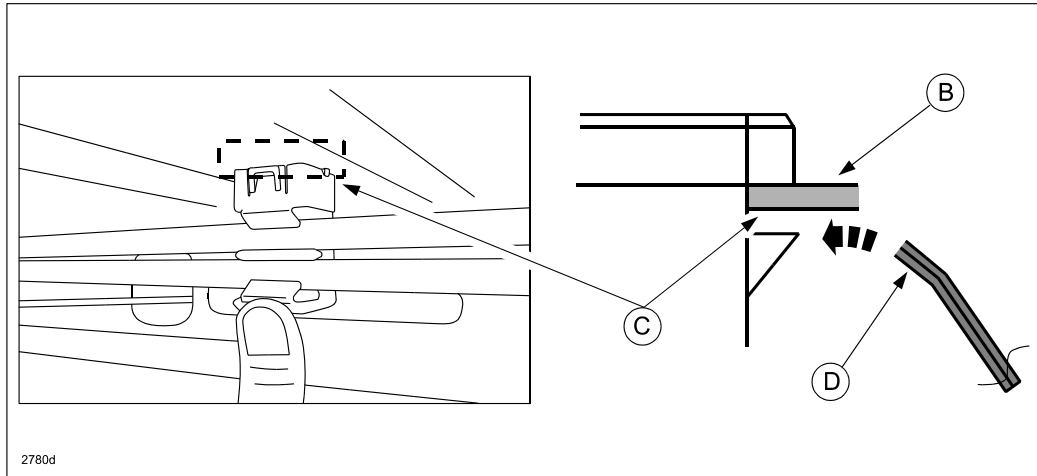

6. Attach the two sheets of non-woven fabric (D) on the clip as shown below.

NOTE: The edge of the sheets should be attached on the clip so that it covers the contact area (C) against the rear package tray panel (B).

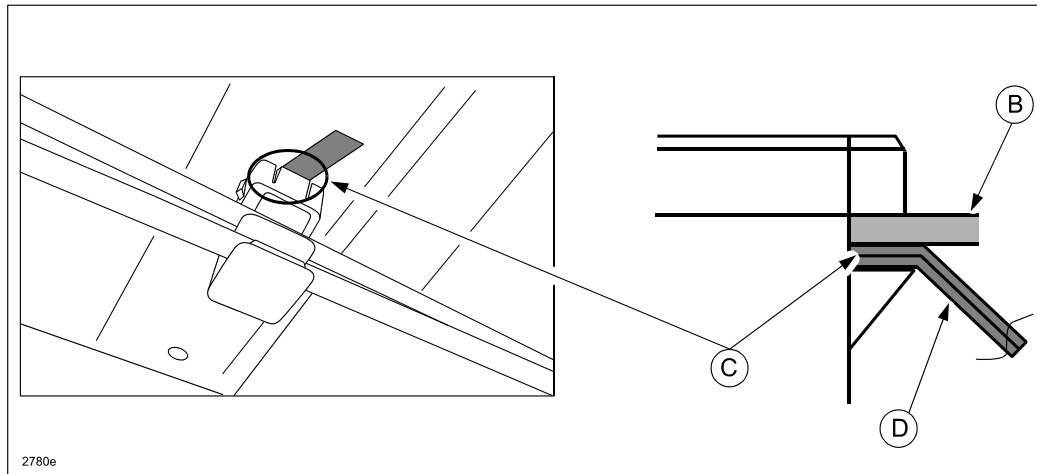

NOTE:

- Attach the sheets along with the configuration of the clip (D).
- If the sheets contact the springs (E), cut the edge appropriately.

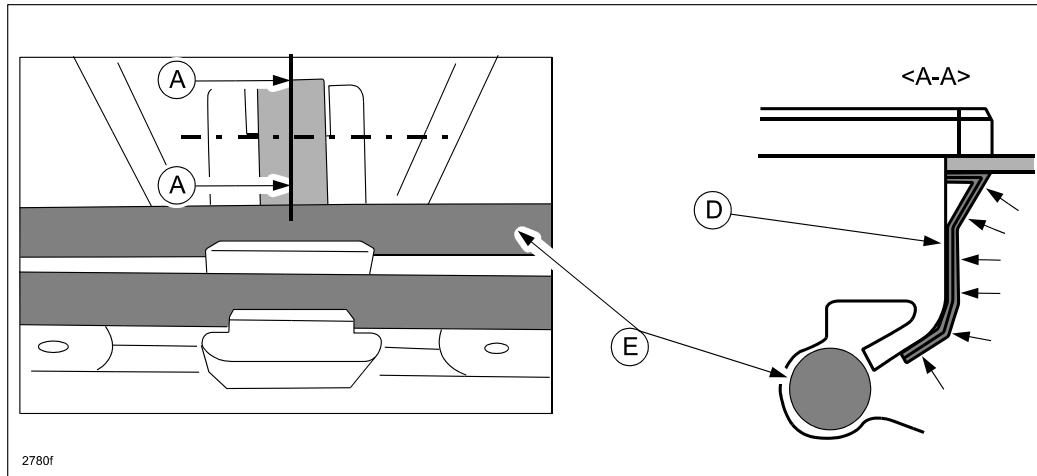

7. Verify repair.

PART(S) INFORMATION

Part Number	Description	Qty.	Notes
TA01-76-100	Noise Parts Set (Noise Repair Kit)	1	Cut two 7mm x 20mm pieces (Can be used for 53 vehicles)

WARRANTY INFORMATION

NOTE:

- This warranty information applies only to verified customer complaints on vehicles eligible for warranty repair.
- This repair will be covered under Mazda's New Vehicle Limited Warranty term.
- Additional diagnostic time cannot be claimed for this repair.

Warranty Type	A
Symptom Code	82
Damage Code	97
Part Number Main Cause	GHK1-56-894 (Clip)
Quantity	0
Operation Number / Labor Hours:	XXJ4AXRX / 0.2 Hrs.

NOTE: Do not claim the noise parts set (P/N TA01-76-100) as a related part. The amount of fabric used for this repair is included in the labor allowance.