

© 2013 Mazda Motor of America, Inc.

<b>Subject:</b> <b>TIRE PRESSURE MONITORING SYSTEM (TPMS) WARNING LIGHT ILLUMINATION - MISUSE PREVENTION LOGIC</b>	<b>Bulletin No:</b> 02-003/13
	<b>Last Issued:</b> 02/06/2013

## BULLETIN NOTE

- This bulletin supersedes the previous bulletin 02-003/12, issued on 12/14/2012 and 09/04/2012. The **DESCRIPTION**, and **REPAIR PROCEDURE** have been revised.
- Changes are noted below in Red beside the change bar.

## APPLICABLE MODEL(S)/VINS

2013-2014 CX-5

2014 Mazda6

## DESCRIPTION

This service bulletin illustrates the conditions when a TPMS warning light may illuminate, why it illuminated and how to properly initialize the system.

The Tire Pressure Monitoring System (TPMS) monitors the tire pressure of all four tires indirectly using the data sent from the ABS wheel speed sensors. If the air pressure of one or more tires is too low compared with the specified value (the initial value learned by the system), the system warns the driver with the TPMS warning light in the instrument cluster and a beep sound. To allow the TPMS to operate correctly, it is essential that the TPMS be initialized to learn new conditions whenever a tire related service is performed.

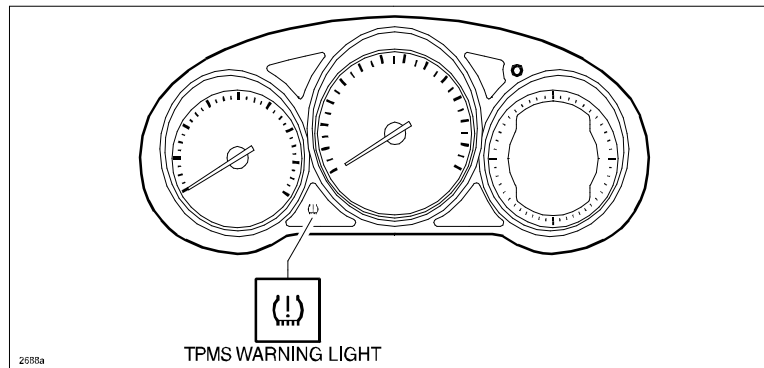

**CONSUMER NOTICE:** The information and instructions in this bulletin are intended for use by skilled technicians. Mazda technicians utilize the proper tools/equipment and take training to correctly and safely maintain Mazda vehicles. These instructions should not be performed by "do-it-yourselfers." Customers should not assume this bulletin applies to their vehicle or that their vehicle will develop the described concern. To determine if the information applies, customers should contact their nearest authorized Mazda dealership. Mazda North American Operations reserves the right to alter the specifications and contents of this bulletin without obligation or advance notice. All rights reserved. No part of this bulletin may be reproduced in any form or by any means, electronic or mechanical---including photocopying and recording and the use of any kind of information storage and retrieval system ---without permission in writing.

**PRE-DELIVERY INSPECTION (PDI) STEPS 1, 3 AND 4:**

To ensure a problem free vehicle sales delivery, PDI Step 1 (VEHICLE RECEIVING PROCESS), PDI Step 3 (MAZDA NEW CAR GET READY INSPECTION), and Step 4 Smart Start Guide (CUSTOMER DELIVERY CHECKLIST) have been revised to include the TPMS initialization procedure. Failing to complete the TPMS initialization will cause the TPMS warning light to illuminate after the customer takes delivery of the vehicle. This may result in:

- Negative customer satisfaction due to comeback repairs.
- Negatively impact your dealerships IQS scores.
- PDI claim debit.

When any of the services below is performed, **BE SURE TO INITIALIZE THE TPMS BEFORE DRIVING THE VEHICLE** by pushing and holding the TPMS Set Switch on the dash (until the TPMS warning light flashes two times and the warning beep sounds once).

• Tire pressures have been adjusted in one or more tires.
• Tires have been rotated.
• Tires or wheels have been replaced.
• The vehicle's battery cable has been disconnected for any reason.
• The vehicle's battery has been discharged.
• The DSC HU/CM connector has been disconnected for any reason.

**NOTE:** Some customers may perform these services by themselves, therefore, be sure to instruct them on the necessity of and the procedure for performing the TPMS initialization.

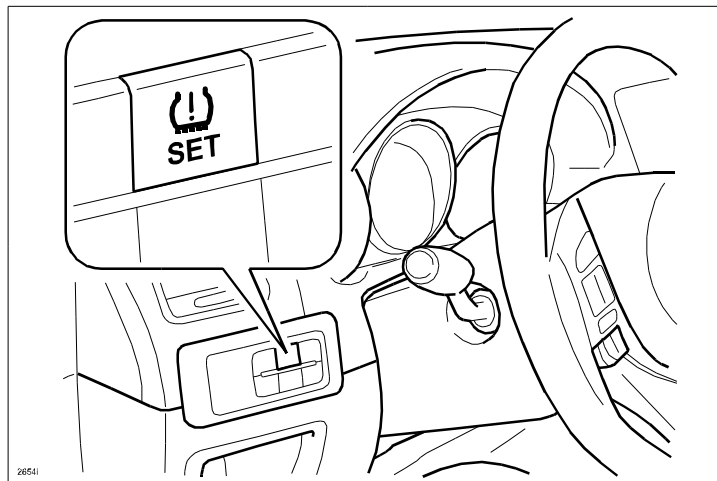

**INCORRECT INITIALIZING:**

Customer complaints have been reported where the TPMS warning light is unnecessarily illuminated because the TPMS initialization was not performed correctly. This service information addresses these cases and the action to be taken.

**CASES WHERE THE TPMS WARNING LIGHT IS ILLUMINATED DUE TO INCORRECT TPMS INITIALIZATION:**

**NOTE: BE SURE TO PRESS AND HOLD THE TPMS SET SWITCH AFTER TIRE PRESSURES ARE ADJUSTED AT PDI.**

Refer to the on-line MS3 instructions or the Workshop Manual (section 02-12 TIRE PRESSURE MONITORING SYSTEM INITIALIZATION PROCEDURE).

**SALES DELIVERY:**

**Example 1:** The tire pressures were adjusted at PDI, but the TPMS initialization was not performed. The TPMS warning light was illuminated right after vehicle delivery.

Tire pressures are set at the plant around 50 psi (350kPa) and the TPMS is initialized. If the TPMS initialization is not performed after the tire pressures are adjusted down at PDI, the TPMS determines that the tire pressures have dropped and the TPMS warning light illuminates.

**Example 2:** For the vehicle in Example 1, the dealer found the tire pressures were correct, therefore, pushed the TPMS set switch, then delivered the vehicle. Right after the vehicle was delivered, the **Misuse Prevention Logic** operated and the TPMS warning light illuminated again.

**Misuse Prevention Logic**

The CX-5 and 2014 Mazda6 use an indirect TPMS (does not measure the tire pressures directly). In order to prevent the system from learning tire pressures that may not be within the tire manufacture specifications, “Misuse Prevention Logic” has been adopted as a warning system.

If the TPMS is initialized without adjusting the tire pressures (even though the TPMS warning light is illuminated), the Misuse Prevention Logic will illuminate the TPMS warning light.

The data for the tire pressure at the time the TPMS warning light illuminates is compared to the data for the tire pressure at the time the TPMS initialization was performed. If the difference in pressure is within the specification, the TPMS warning light will illuminate again. This prevents the system from learning tire pressures that may not be within the tire manufactures specs.

There are two types of mis-use prevention logic, Type A and Type B.

- 2014 Mazda6 - Type B has been adopted from the start of production.
- CX-5 - Type can be verified by the first four digits of the part number (A) of DSC HU/CM (B) which is indicated on the label adhered to the DSC HU/CM.

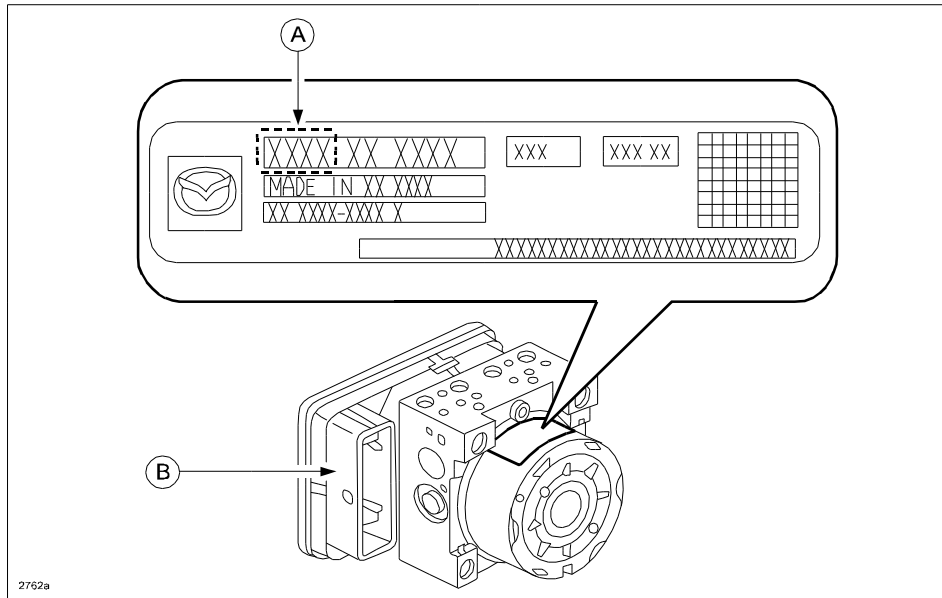

Misuse Prevention Type	First 4 digits of DSC HU/CM part number	Model
Type A	K011 or K0Y1	CX-5
Type B	KJ11 or KJY1	
Type B	---	2014 Mazda6

### Type A Misuse Prevention Logic Operation:

The misuse prevention logic operates two times and the warning light illuminates each time as shown below.

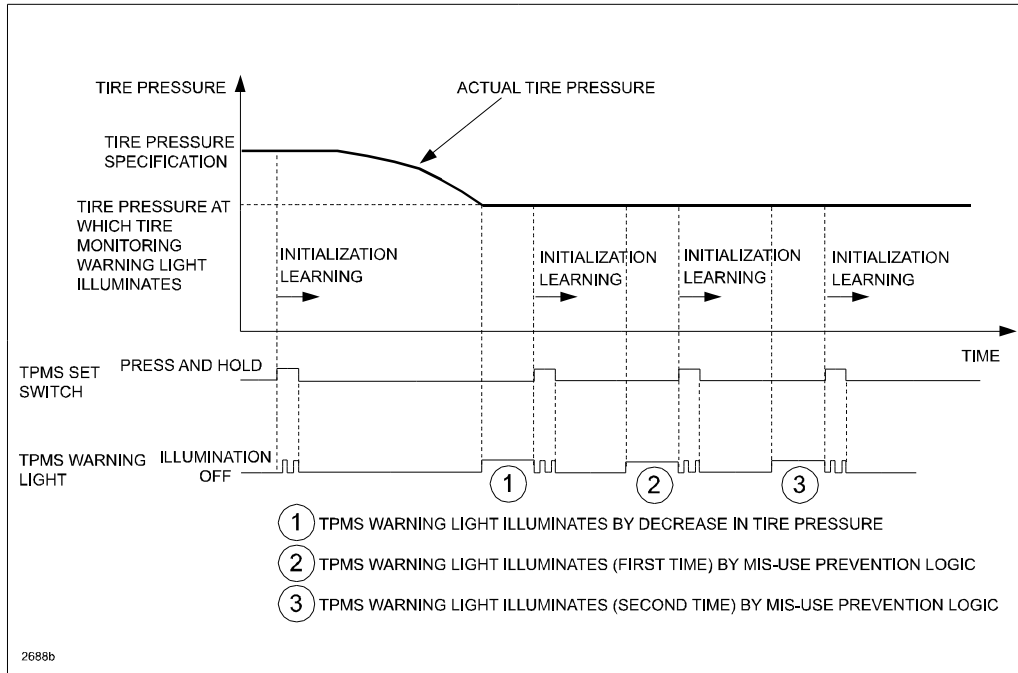

### Type B Misuse Prevention Logic Operation:

- If the detection is the first time, the tire pressure monitoring system warning light is not illuminated.
- If the detection is the second time, the tire pressure monitoring system warning light is illuminated.

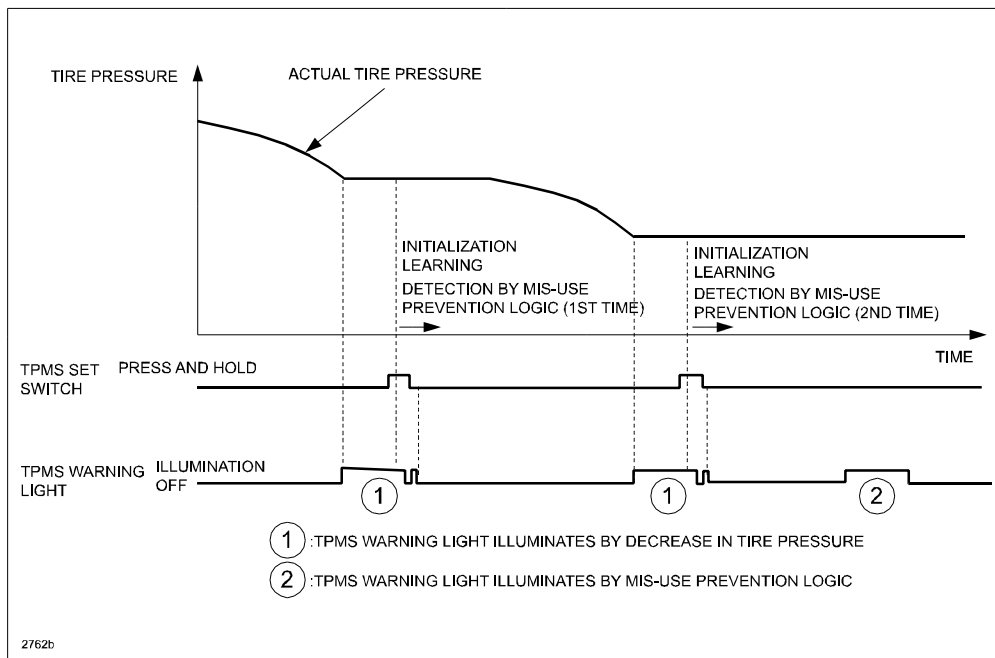

## REPAIR PROCEDURE

If the cases mentioned above are encountered, inspect and measure according to the following procedures.

When the TPMS warning light illuminates, even though the tire pressures are within specification, the following reasons (A and B) are possible:

### (A) The TPMS detected the tire pressure decrease:

- The vehicle in Example 1 applies to this case.
- Tire pressures were adjusted to the specified value, but the initialization was not performed by the dealer at PDI. Previously, the tire pressures were adjusted to a higher value than the specification. Then the tire pressures were decreased and the warning light illuminated.

### (B) The TPMS Misuse Prevention Logic activated:

- The vehicle in Example 2 applies to this case.
- The customer pressed the TPMS set switch without adjusting the tire pressures.

To distinguish between reasons A and B, connect IDS, go to "IDS Tool Box > Operational Record > TPMS > Read Operational Record" and confirm the odometer, elapsed days, vehicle speed, etc. at the time the TPMS set button was pushed and the warning light illuminated.

### NOTE:

- The TPMS initialization at the plant may not be recorded.
- Even if the TPMS set switch was pressed at PDI, the TPMS initialization might not have been performed if the battery was disconnected after pushing the TPMS set switch and before the learning process.

### Misuse Prevention Logic Reset:

Depending on **mis-use prevention logic type**, the misuse prevention logic can be reset.

Misuse Prevention Logic Reset	Type A	Proceed to Action 1
	Type B	Proceed to Action 2

### ACTION 1 (Type A Misuse Prevention Logic Reset)

Increase the tire pressures by 7 psi (50kPa) [specified value + 7 psi (50kPa)] and perform the TPMS initialization procedure to let the system learn the tire pressure.

1. Adjust all four (4) tires pressures to the specified value + 7 psi (50kPa).
2. Press and hold the TPMS Set Switch on the dash until the TPMS warning light flashes one or two times and the warning beep sounds once.

- To initiate TPMS learning, drive the vehicle over 20 minutes at one of the constant speed ranges indicated in the table below.

**CAUTION:** Drive carefully and pay close attention to the changed vehicle driving characteristics with the increased tire pressures.

**NOTE:** TPMS learning is temporarily suspended when braking or turning the steering wheel, so try to drive the vehicle on a straight road with a smooth surface without stopping as much as possible.

Vehicle Speed Range	MPH (Km/h)	Driving Time
Low speed	31 ± 6 mph (50±10 Km/h)	Over 20 minutes
Mid speed	44 ± 6 mph (70±10 Km/h)	Over 20 minutes
High speed	56 ± 6 mph (90±10 Km/h)	Over 20 minutes

- Connect IDS, check the PID “DDS-MODE”.

- **If it says “Learned”, TPMS learning has been completed.**
- **If TPMS learning has not been completed, repeat steps beginning with Step 3.**

**NOTE:** For the TPMS unit data processing to change the status from “Learning” to “Learned”, turn the ignition OFF, close the doors and let the vehicle sit for more than five (5) minutes.

- After the TPMS learning has been completed, adjust the tire pressures to the correct specification.
- Initialize the TPMS by pressing and holding the TPMS set switch on the dash until the TPMS warning light flashes one or two times and the warning beep sounds once.

## **ACTION 2 (Type B Misuse Prevention Logic Reset)**

### **Using IDS Version 81 or Higher**

- Park the vehicle on safe, level ground.
- Adjust all four tire pressures to the specification while the tires are cold. (See tire label located on the driver’s side B-pillar or edge of the driver’s door frame)

**CAUTION:** Cold tires means leaving the vehicle for 1 h or, if the vehicle is driven, do so within 1 mile (1.6 km).

- Connect the IDS to DLC-2.
- After the vehicle is identified, select the following items from the initial screen of the IDS.
  - Select “Chassis”
  - Select “ABS/DSC”
  - Select “TPMS Reset”

**NOTE:**

- This IDS reset can be performed anytime the TPMS Warning Light is illuminated.
- When the tire pressure monitoring system initialization is performed, learning initiates. Learning is completed by driving the vehicle for approx. 20 min.
- While the tire pressure monitoring system is undergoing learning, its primary functions do not operate.