





## AVERTISSEMENT

When disconnecting hoses and components, do not spill DEF onto separated connectors. If this occurs, replace the connectors immediately. Cleaning with water or compressed air will not help as the DEF quickly oxidizes metal and, due to capillary action, “creeps” along cabling at a speed of about 0.6 meters/hour.



## WARNING

DEF spilt onto hot components will quickly vaporize. Turn your face away!



## WARNING

Aftertreatment DEF is an irritant. Contact with DEF can irritate the skin and eyes. Inhaling DEF mist can cause lung irritation. Avoid DEF contact with skin and eyes. Avoid breathing mist created by DEF spray.

### *NOTE*

1. *If the DEF lines will remain open for an extended period of time, seal the opening to prevent crystallization of fluid in the line.*
2. *Note: Before removing appropriate coolant and DEF lines, please mark them to ensure proper reinstallation to the correct location*

1. Locate the DEF tank on the vehicle.

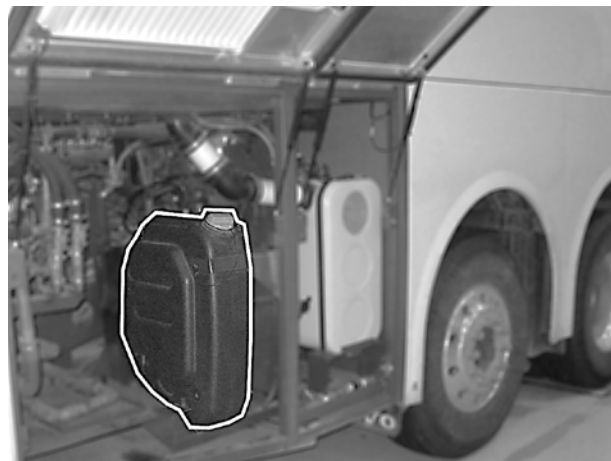

2. Disconnect the electrical harness from the DEF quality sensor module electrical connector (1).

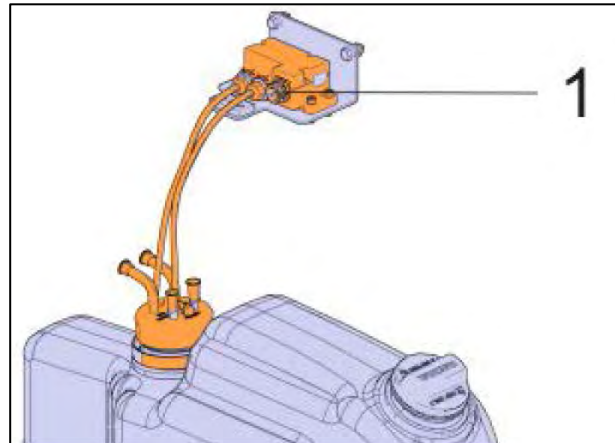

(1) Connector on UQS module

3. Modify connector pin out according to FIGURE 2.
4. *Protect with a plastic bag to avoid any DEF contamination.*

Figure 1 : UQS 22073036 Pin-out

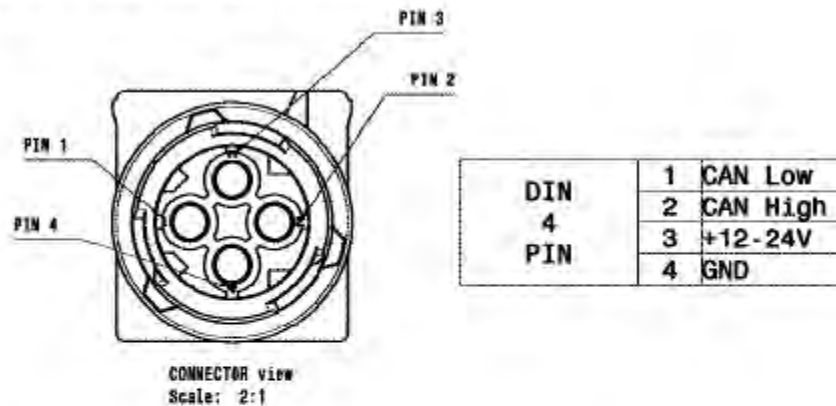
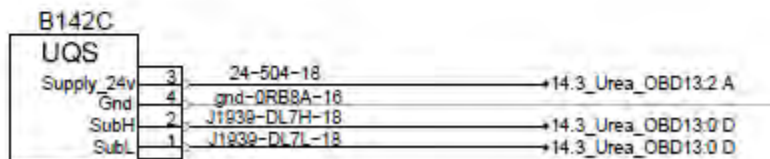
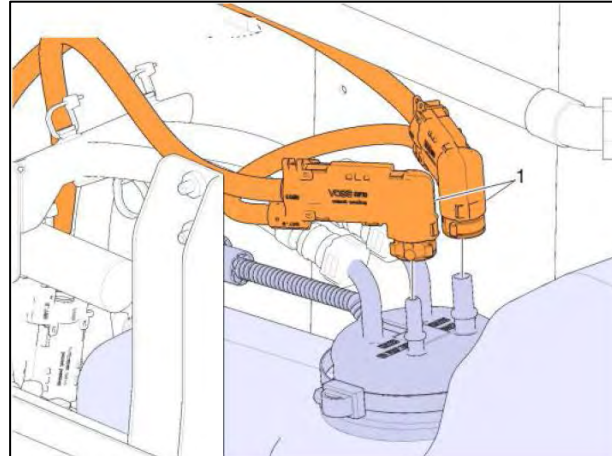
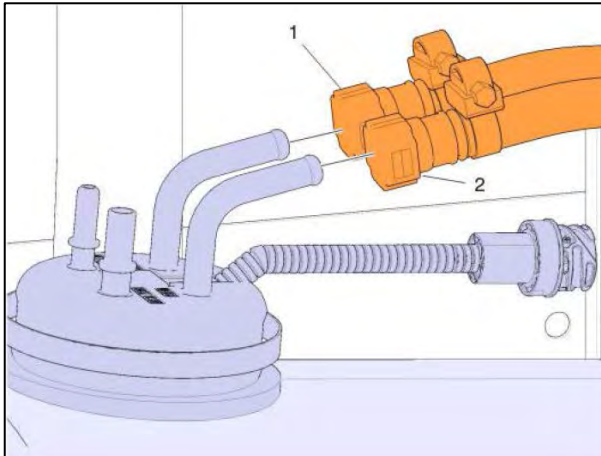
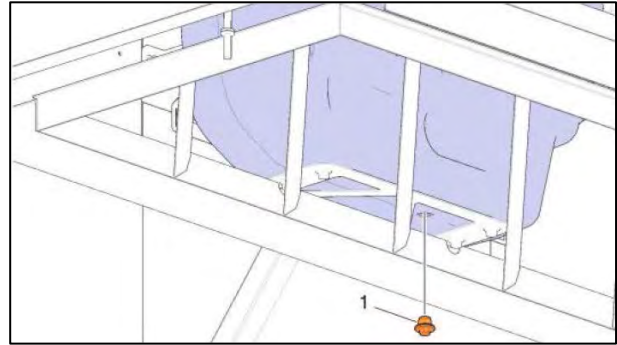

Figure 2 : Schematic of connector



## REMOVAL

5. Clamp the heating hoses. Drain any coolant in an appropriate container.
6. Place a container under the DEF tank to collect any spilt DEF fluid or coolant.
7. Remove tank bottom plug and empty in an appropriate container.
8. Once the tank is empty, reinstall plug and tighten.
9. Disconnect coolant and DEF hoses. Note their position to ease re-assembly.



10. Remove tank to create space to install new module.

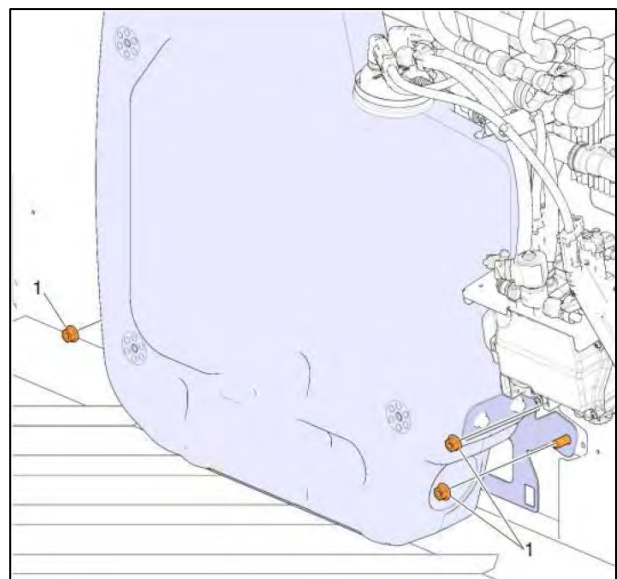

11. Loosen the clamp holding the sensor and remove from tank.

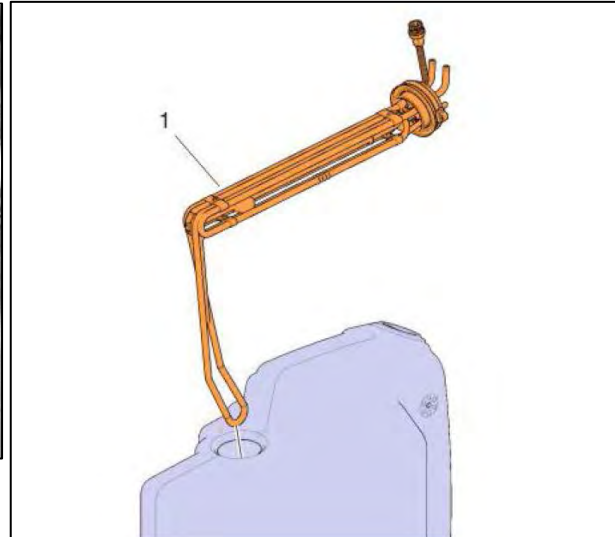
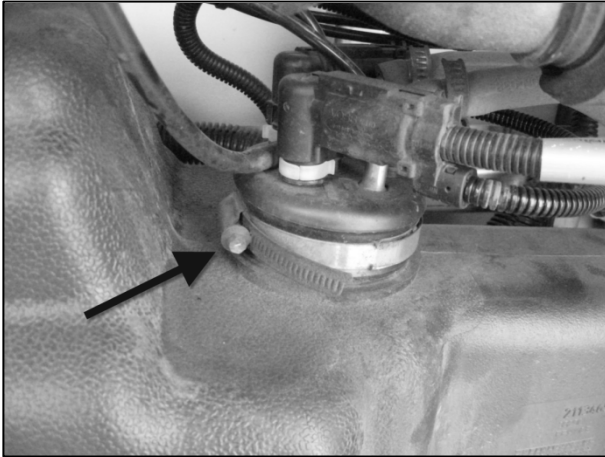

12. Un screw the four mounting screws on the electronic module. Reserve for future assembly.

## INSTALLATION

13. Insert the new sensor in the DEF tank and install new electronic module.

Handle the new sensor with care to avoid damage to the sensor.

- Tighten module screws to 106 lbf-in.
- Tighten clamp to 29 lbf-in



14. Install tank on vehicle.



15. Install all hoses on the sensor cap.

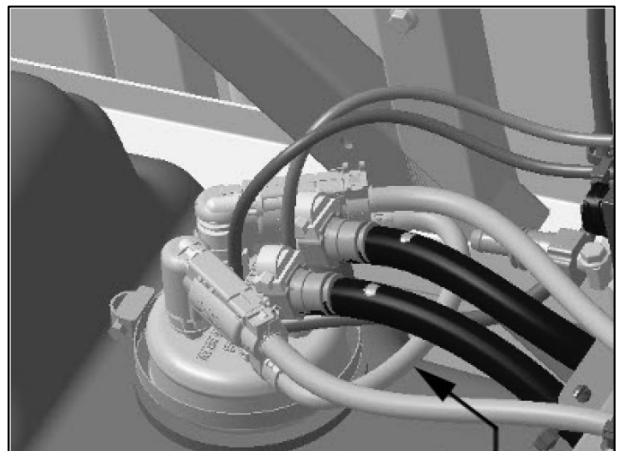

16. Remove the plastic bag on the connector and connect to electronic module.

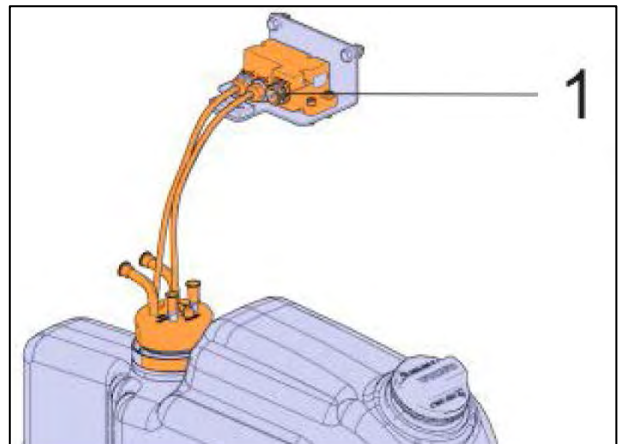

17. Fill the tank with new DEF fluid.
18. Remove clamps on the heating system hoses and fill system with coolant saved earlier.
19. Use tech tool to remove any error code present (DTC) and perform "Learned Data Set"
20. Start vehicle, detect any leaks and make sure all systems operate properly.

## PARTS / WASTE DISPOSAL

Return replaced parts to Prevast with A.F.A. for full reimbursement.

## WARRANTY

This modification is covered by Prevast's normal warranty. We will reimburse you the parts and three hours (3.0h) of labor upon receipt of the replaced parts and a completed A.F.A. form on which you must specify as per "Warranty Bulletin Bulletin Volvo : quel logo".

## TELL US WHAT YOU THINK!

We are interested in hearing your comments or suggestions regarding this bulletin. Please e-mail them to: [TechnicalPublications\\_prev@volvo.com](mailto:TechnicalPublications_prev@volvo.com)

## OTHER

VBC Campaign	N/A
Fail Code	04.04-1
Defect Code	09
System Condition	B
Causal Part	21891229

Prevast engages in a continuous program of testing and evaluating to provide the best possible product. Volvo Bus, however, is not committed to, or liable for updating existing products.