



Service Bulletin

File in Section: -

Bulletin No.: PI1141

Date: December, 2013

PRELIMINARY INFORMATION

Subject: 2014 Cadillac ELR Coupe New Model Features

Models: 2014 Cadillac ELR Coupe Extended Range Electric Vehicle (EREV)
Equipped with EREV Technology — RPO EVB and 4 CYL, 1.4L, MFI, DOHC Gas
Powered Generator — RPO LUU
Equipped with Fully Automatic, Front Wheel Drive (FWD), Electronically Controlled,
4ET50 Variable-Speed Transaxle — RPO MKA

Bulletin Purpose



3655068

This is a special bulletin to introduce the new 2014 Cadillac ELR Extended Range Electric Vehicle (EREV). The purpose of this bulletin is to familiarize Dealership Sales and Service Personnel with the vehicle's features and also describe the actions the Service Department Personnel will need to take to ensure they are able to fully service this exciting new model.

About the Vehicle

The 2014 Cadillac ELR is a sleek luxury coupe that features the first application of Extended Range Electric Vehicle (EREV) technology by a full-line luxury automotive brand. The ELR is an unprecedented combination of luxury, advanced engineering and progressive design that is both sporty and environmentally friendly. The exterior establishes a new, progressive theme and proportion by utilizing an aggressive, forward-leaning profile. The overall shape is reinforced by a prominent, sweeping body line accented by pushing 20-inch wheels to the edges of the body. Aerodynamics play a crucial role in the design of the exterior as airflow is managed to help the vehicle slip through the air with minimal drag. A flush front fascia and grille – with active shutters behind the grille opening as well as tapered fascia corners, enable air to move easily around the car to reduce drag. In the rear, sharp edges and a carefully designed spoiler also manage airflow. An aggressive rake on the windshield and back glass help reduce turbulence and drag and contribute to ELR's 0.305 coefficient of drag.

ELR uses active noise cancelling to uniquely preserve the peace and quiet. While most cars that use this type of sound-neutralizing technology aim simply to mute exhaust boom at low engine speeds, such as when idling, ELR uses it across all engine speeds. The active noise cancelling system electronically gathers input from the vehicle's generator and powertrain, as well as from three ceiling-mounted microphones. The system calculates and produces the appropriate noise-cancelling signal, which is delivered through the Bose® audio system's speakers and subwoofer.

The ELR's dramatic design is matched with an engaging driving experience, calibrated for uncompromising performance. With 295 lb-ft of torque (400 Nm), about 12 percent more than the 3.6L V-6 in the SRX, acceleration in the city and on the highway, including merging and passing is achieved with reassuring power on demand. Driving confidence is further enhanced by advanced suspension and damping systems, including Continuous Damping Control which adjusts damping every two milliseconds, to maintain optimal vehicle ride control over varying road surfaces and profiles. A solid, stable foundation underpins the ELR, featuring a body-frame-integral structure with main underbody rails running continuously from front to rear. Advanced, high-strength steels add strength and conserve weight.

Additional vehicle highlights include:

- Wide front and rear tracks and a low center of gravity.
- HiPer Strut front suspension featuring lightweight forged aluminum components for reduced weight enabling more nimble response.
- Dual-pinion, rack-mounted electric power steering system with premium ZF steering gear designed to provide excellent feedback while helping to save fuel.
- A semi-independent rear compound-crank suspension with Watts link that incorporates weight-optimized trailing arms to absorb lateral forces, allowing the suspension to be tuned to handle vertical, forward and rearward motions.
- Hydraulic ride bushings in the front and rear suspensions.
- Standard chassis control systems include antilock brakes, traction control and StabiliTrak electronic stability control.

Additional interior highlights include:

- Interior design featuring cut-and-sew accented leather incorporating sueded microfiber, chrome, wood and available carbon fiber finishes throughout.
- Available Opus semi-aniline leather seating.
- Auto-glide/power assisted covered storage/cup holder in the center console.
- Fold-down rear seat backs accommodate longer items, including multiple sets of golf clubs.
- LED powered accent lighting in the instrument panel and doors.
- 8-inch (203-mm) configurable instrument and driver information displays, offering four different configurations.

The industry-leading EREV technology provides an EV range of approximately 35 miles (56 km) and a full driving range of approximately 300 miles (480 km), by combining pure electric driving and an efficient, range-extending 1.4L gas powered generator. The responsive EREV driving technology is enhanced with exclusive Regen on Demand™ and selectable Drive Modes that enhance the driving experience and make the most of efficiency. Regen on Demand™ allows the driver to temporarily regenerate energy from the momentum of the vehicle into electricity that can be stored in the battery pack for later use. It is engaged via steering-wheel paddles adapted from traditional performance cars.

Vehicle Construction

The construction is single body-frame-integral (unibody) with front and rear crumple zones, galvanized steel front fenders, roof and door panels, an aluminum hood, a one-piece body side outer panel and thermal plastic olefin (TPO) bumper fascias. The ELR is considered a compact car and is built at the Detroit-Hamtramck Assembly plant in Michigan. Top speed is 100 mph (160 km/h).

Unique Characteristics and Normal Operating Conditions

Drivers of the ELR may experience some operating characteristics that are unique to this vehicle. Due to the quiet nature of the propulsion system, certain sounds that may have been masked by the engine's natural harmonics will be apparent. Among them is the electric engine cooling fan, coolant pumps, the air conditioning compressor and the HVAC blower. In addition to those sounds, the drive motor battery cooling system may be operational during charging or when the vehicle is powered down. This may be more evident when charging or during remote cabin conditioning. Due to the electric nature of the vehicle, the electric motor may be heard as the vehicle moves. This is a normal operating characteristic.

Pedestrian Safety Signal — Automatic and Manual

This alert was developed in conjunction with the American Federation of the Blind. Because the ELR operates so quietly in all-electric mode, it is equipped with an **automatic sound** generation feature and a manual alert. The automatic sound is generated at speeds below 20 mph (32 km/h) to indicate the vehicle's presence to pedestrians. The sound changes when the vehicle is speeding up or slowing down. It is activated when the vehicle is shifted into a forward gear or **R** (Reverse), up to 19 mph (30 km/h).

A **manual alert** can be sounded while driving, such as in parking lots. Use this feature to alert people who may not hear your vehicle approaching. At speeds less than 40 mph (64 km/h), to manually sound the pedestrian safety signal perform the following:

1. Pull the turn signal lever all the way toward you momentarily. The high-beam headlamps and indicator light will turn **ON**, and a soft-note alert will momentarily sound. When the turn signal lever is released, the high-beam headlamps and indicator light will turn **OFF**.
2. **Repeat** the action for additional activations of the pedestrian safety signal as needed.

High Voltage Lithium-Ion Drive Motor Battery System

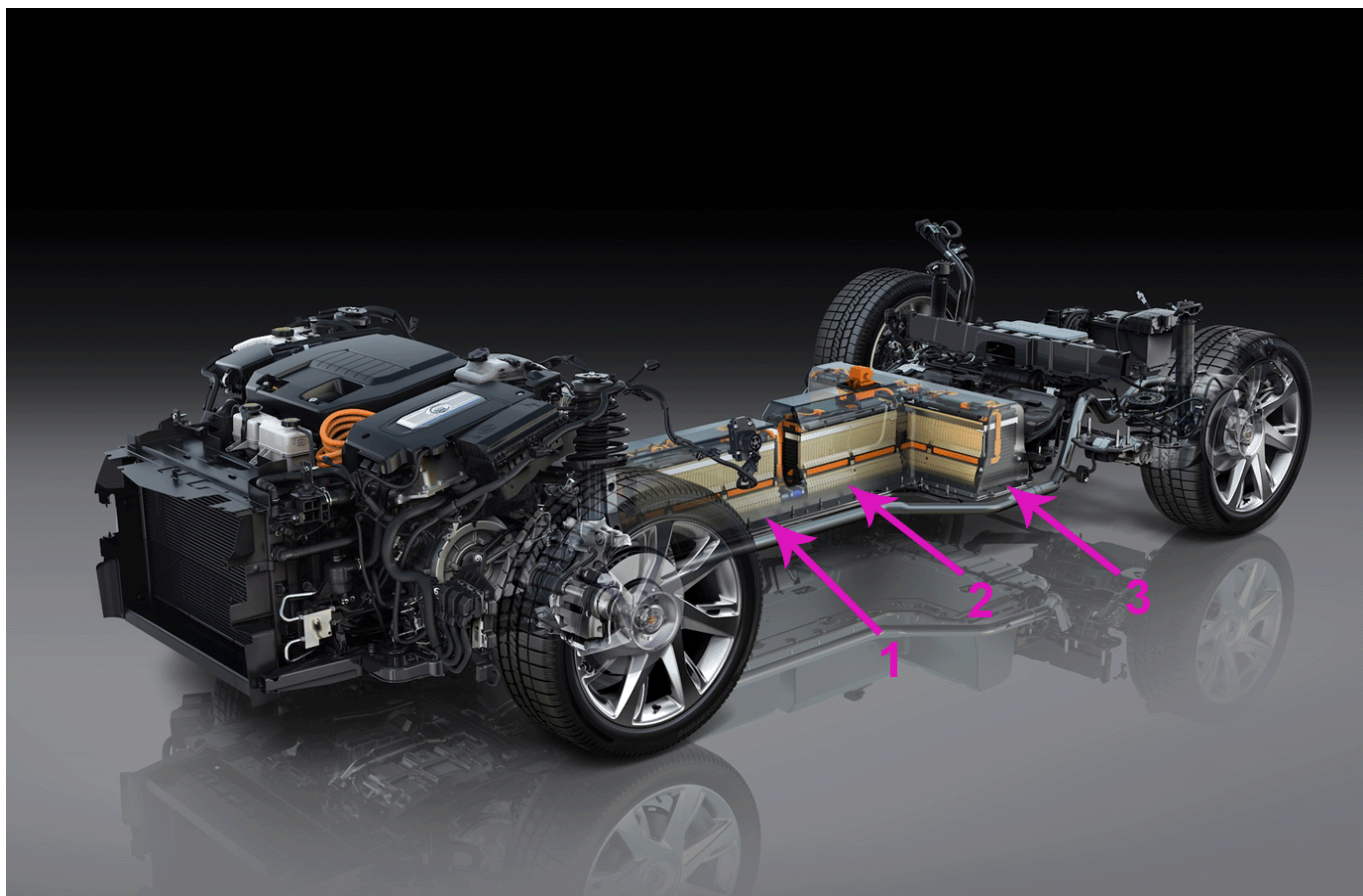

3657752

The heart of the ELR's Electric Propulsion system is its advanced Lithium-Ion Drive Motor Battery System. The electric propulsion system drives the vehicle.

The hybrid battery contains 288 cells. Groups of three cells are welded together in **parallel** called cell groups. There are a total of 96 cell groups in the hybrid battery assembly. These cell groups are electrically connected in series. Each individual cell group is rated at 3.7 V, for a nominal system voltage of 355 V direct current. The battery cell groups are joined to form three distinct sections.

- The first 30 battery cell groups make up battery **Section 1**. This section is adjacent to the instrument panel and contains battery cell groups 67 through 96.
- The next 24 battery cell groups make up battery **Section 2**. This section is located behind section 1 and contains battery cell groups 43 through 66.
- The transverse battery is **Section 3** and it contains the remaining battery cell groups 1 through 42.

The battery energy control module monitors the voltage of the 96 battery cell groups through 4 hybrid battery interface control modules. There is one hybrid battery interface control module for section 1 and 2, with section 3 having two modules. The voltage sense lines are attached to each individual cell group, and these sense lines terminate at a connector located on the top surface of the battery section. A voltage sense harness joins this connector to the hybrid battery interface control modules, located on the top surface of the battery section. The hybrid battery interface control module encodes the voltage reading and transmits it to the battery energy control module through the battery energy control module harness.

The battery energy control module will determine when a fault condition is present. Diagnostics and system status are communicated from the battery energy control module to the hybrid powertrain control module 2 through serial data. The hybrid powertrain control module 2 is the host controller for diagnostic trouble code information. The battery is liquid cooled for long life and optimum performance.

The HV battery is located beneath the vehicle (shown). The battery energy control module, battery interface control modules 1-4, current sensor, and high voltage contactors are located within the battery assembly. The powertrain control module 2 is located under the front passenger seat.

Notice:

- **PRIOR to performing service, ensure all High Voltage Safety procedures and Warnings are followed exactly as written. Personal Protection Equipment (PPE) MUST be worn and proper procedures MUST be followed.**
- **Service Technicians will perform internal battery service and drive unit service as guided by the TAC Technical Assistance E-Team.**

Manual Service Disconnect (MSD) Located Under Front Floor Console Rear Trim Panel

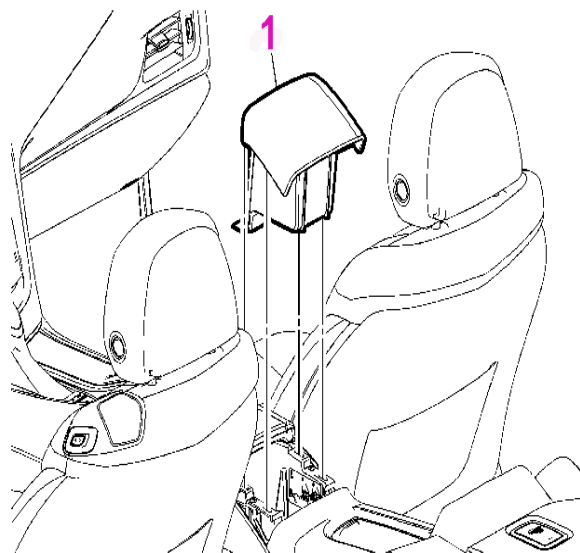

3671817

The Manual Service Disconnect (MSD) is located under the front floor console rear trim panel (1) as shown. Removing the rear trim panel will expose the MSD. Refer to Front Floor Console Rear Trim Panel Replacement in SI.

Hybrid Modes of Operation

The ELR is an electric vehicle with extended range capability. Plug it in, let it charge overnight, and it's ready to run on a pure electric charge — gas and tailpipe emissions free. After that, the ELR uses a range-extending 1.4L gas powered generator that produces enough energy to power it for hundreds of miles on a single tank of gas.

Electric Mode

In Electric Mode, the ELR will not use gasoline or produce tailpipe emissions. During this primary mode, the ELR is powered by electrical energy stored in its high voltage propulsion battery. It can operate in this mode until the battery is depleted to a predetermined level. Electric range is affected by colder outside temperatures. During colder months, the energy needed to warm the vehicle's cabin and high voltage propulsion battery can cause the vehicle's electric range to decline.

Notice: Refer to the latest version of PIC5414C: (EREV) Explanation Electric Range Variation and Driving Tips For Maximum Range



3657769

Use the Efficiency Gauge in the instrument cluster (IC) and the following driving style tips to avoid unnecessary aggressive/inefficient accelerations and decelerations to help maximize energy efficiency and range.

- **Driving Style:** Avoid aggressive/inefficient acceleration by observing the Efficiency Gauge in the IC. Aggressive/inefficient acceleration is indicated when the ring turns yellow or the leaf turns yellow and travels above the center of the gauge. The leaf indicator or green ring indicator should be kept green and in the center of the gauge.
- **Driving Style:** Avoid aggressive/inefficient braking by observing the Efficiency Gauge in the IC. Aggressive/inefficient braking is indicated when the ring turns yellow or the leaf turns yellow and travels below the center of the gauge. Plan ahead for decelerations and coast whenever possible. For example, do not rush to traffic signals.
- **Cruise Control:** Use cruise control when appropriate.
- **Coasting:** **DO NOT** shift to **N** (Neutral) to coast. The vehicle recovers energy while coasting and braking in **D** (Drive) or **L** (Low).
- **Electric Range:** Electric range is maximized at 50 mph (80 km/h) and below. Higher speeds use more energy and can significantly reduce electric range.

Extended Range Mode

Once the electric charge is depleted, the range-extending gas powered generator will start to generate enough power to continue driving the vehicle. Engine operation ensures that you will not be stranded by a depleted battery. The vehicle determines when the engine needs to run. Engine speed will vary, depending on driving conditions, to optimize efficiency. The hybrid/EV battery pack will not be recharged while in extended range mode. The vehicle must be plugged in to recharge the hybrid/EV battery pack completely. Total vehicle range is based on the available combined electric and extended range. The displayed electric and fuel ranges are projections based on past vehicle performance and charge/fuel level. The displayed ranges will change based on driving style, outside temperature and climate settings.

Regenerative Braking

When the vehicle is coasting or braking the power inverter module may operate the drive motor as a generator in an Electrical Generation Mode. Operating as an electrical generator, the drive motor exerts a driveline load that helps to slow the vehicle. The electrical energy that the drive motor creates is transferred by the power inverter module to the hybrid/EV battery pack. Constant communication between the power inverter module and the electronic brake control module allows the blending of regenerative braking force with hydraulic braking force.

Regen on Demand™

This feature will slow the vehicle by recapturing energy using the steering wheel paddles. It works in **D** (Drive) and **L** (Low). The accelerator pedal must be fully released for it to work. The brake pedal must be applied at low speed, because it will not stop the car. Cruise control will turn **OFF**, and the brake lights may turn **ON**, when this feature is activated.



3671078

To activate Regen on Demand™, **pull and hold** either paddle on the back of the steering wheel without pressing the brake pedal or accelerator pedal. While pulling either paddle, the vehicle will begin to decelerate using regenerative braking. Regen on Demand™ is deactivated once the paddles are released, or the brake pedal or accelerator pedal is pressed.

Internal Combustion Engine (ICE) Starting

This vehicle does not use a 12 V starter motor to crank the ICE. A much more powerful 300 V motor, drive motor 1, located within the transmission is utilized to crank the ICE. Drive motor 1 can rotate the ICE to operating speed of 800 RPM within just a few hundred milliseconds. This allows near-instant starting of the ICE.

The vehicle's on-board computers determine when the ICE needs to run. Some of the normal vehicle conditions that force the ICE to run are:

- The hybrid/EV battery pack has a low state of charge.
- The **hood is open** or not completely latched.
- The ICE is needed to maintain the hybrid/EV battery pack temperature.
- The ICE needs to run for maintenance.
- Low ambient temperatures.
- **At temperatures of 35°F (2°C) and colder, the ICE can start up to provide both electric power as well as provide heat to supplement the electric heater. This can happen in cold ambient temperatures, dependent upon climate settings and temperature, regardless of battery charge level.**

Engine Unavailable

If the vehicle runs out of fuel, or the power inverter module has detected the ICE will not start due to a malfunction, the vehicle can continue to be driven in Electric Mode.

Maintenance Modes

Engine Maintenance Mode: Engine Maintenance Mode runs the engine to keep it in good working condition when the vehicle has been operated in Electric Mode only for a prolonged period. Engine Maintenance Mode will run the ICE, even if the hybrid/EV battery pack state of charge is sufficient to operate the vehicle in Electric Mode.

Fuel Maintenance Mode: When only Electric Mode has been used for a prolonged period, Fuel Maintenance Mode will run the ICE to use up old fuel. The ICE will run until enough fresh fuel is added or a low fuel level is detected. During Fuel Maintenance Mode the ICE may cycle **ON** and **OFF**.

Service Mode

Service Mode is available for service and diagnostics and to verify the proper operation of the MIL and may be required for emission inspection purposes. With the vehicle **OFF**, and the brake pedal not applied, pressing and holding the **POWER** button for more than 5 seconds will place the vehicle in Service Mode. The instruments and audio systems will operate as they do in **ON**, but the vehicle will not be able to be driven. The propulsion system will not start in Service Mode.

Gas Powered Generator



3665297

The underhood gas powered electric generator is a 1.4L DOHC inline four cylinder engine that produces 83 HP (62 kW) and combined with electric can produce 295 lb. ft. (400 Nm) of torque. The block is cast iron with cast aluminum cylinder heads, displacement is 85.3 cu in/1398 cc. Bore and Stroke 2.89 x 3.25 in / 73.4 x 82.6 mm. The valve train system consists of overhead camshafts, four valves per cylinder, and continuously variable intake and exhaust cam phaser. The ignition system uses individual coil-on-plug modules and sequential multi-port fuel injectors with electronic throttle control. Premium gasoline with a posted octane rating of 91 or higher is required.

Recommended dexos1™ Oil Viscosity Grade

Notice: DO NOT use other viscosity grade oils such as SAE 10W-30, 10W-40, or 20W-50.

ACDelco dexos1™ Synthetic Blend SAE 5W-30 is the recommended viscosity grade for the 1.4L gas powered generator.

Cold Temperature Operation: In an area of extreme cold, where the temperature falls below **-20°F (-29°C)**, an SAE 0W-30 oil may be used. An oil of this viscosity grade will provide easier cold starting for the engine at extremely low temperatures.

Refer to this General Motors website for dexos1™ information about the different licensed brands that are currently available: <http://www.gmdexos.com>

Important Information About Portable Electric Vehicle Charging

Notice: Please share this important information about Portable Electric Vehicle Charging with each customer at delivery. For the customer's future reference, direct the customer to these key points that are contained in the ELR Owner Manual > Driving and Operating > Charge Cord

- Before you plug in to any electrical outlet, have a qualified electrician inspect and verify the electrical system (electrical outlet, wiring, junctions and protection devices) for heavy-duty service at a 12 amp continuous load.
- Electrical outlets may wear out with normal usage or be damaged over time, making them unsuitable for electric vehicle charging.
- Check the electrical outlet/plug while charging and discontinue use if the electrical outlet/plug is hot, then have the electrical outlet serviced by a qualified electrician.
- Mount the Charge Cord to reduce strain on the electrical outlet/plug.
- DO NOT use extension cords, multi-outlet power strips, splitters, grounding adapters, surge protectors, or similar devices.
- DO NOT use an electrical outlet that is on a circuit with other electrical loads.

Drive Motor Battery Charging

Battery

The ELR is powered by a lithium-ion high voltage battery pack, which holds its charge efficiently and has no memory effect, so it doesn't have to be run down completely before recharging. Keep the vehicle plugged in, even when fully charged, to keep the battery temperature ready for the next drive.

Charging Time

The ELR can be programmed for three charging modes: Immediately upon plug-in; Delayed based on departure time; and Delayed (Electric Rate and Departure Time). Using a 120 volt standard outlet will take approximately 12.5 hours to charge the ELR at the 12 amp setting, or 18 hours at the 8 amp default setting. Using a 240 volt charging station will take approximately 5 hours. Charge times will vary with outside temperature.

- Touch the "Green Leaf" **Energy** "icon" on the infotainment touch screen and then touch the **Charging** "icon" to view the current Charge Level and Charge Mode status.
- Touch the green **Charge Level** "text" to select a different charge level.
- Touch the green **Charge Mode** "text" to select a different charge mode.

Programmable Charging Modes

To change charge modes, press the **Leaf** button and touch the **Charging** tab on the center stack. There are three different charge modes:

- **Immediate:** The vehicle starts charging as soon as it is plugged in.
- **Delayed Based on Departure Time:** The vehicle estimates the charging start time considering the programmed departure time for the current day of the week.
- **Delayed based on Electric Rate & Departure Time:** The vehicle estimates the charging start time based on the utility rate schedule, utility rate preference, and the programmed departure time for the current day of the week. The vehicle will charge during the least expensive rate periods to achieve a full battery charge by the departure time.

Charging Status

Charging Status Indicators are located on the instrument panel near the windshield and in the side mirrors (if activated).

Charging Status Indicator (Instrument Panel)



3665320

- **Solid green with single horn chirp** – Vehicle is plugged in; battery is charging
- **Slow (long pulse) flashing green with double horn chirp** – Vehicle is plugged in; battery charging is delayed
- **Fast (short pulse) flashing green** – Vehicle is plugged in; battery is fully charged
- **Solid yellow** – Vehicle is plugged in; not charging
- **No light** – Vehicle is not plugged in OR there is an issue with the charger or outlet
- **No light and repetitive horn chirps** – Electricity was interrupted before charging was completed

Charging Status Indicator (Side Mirrors)

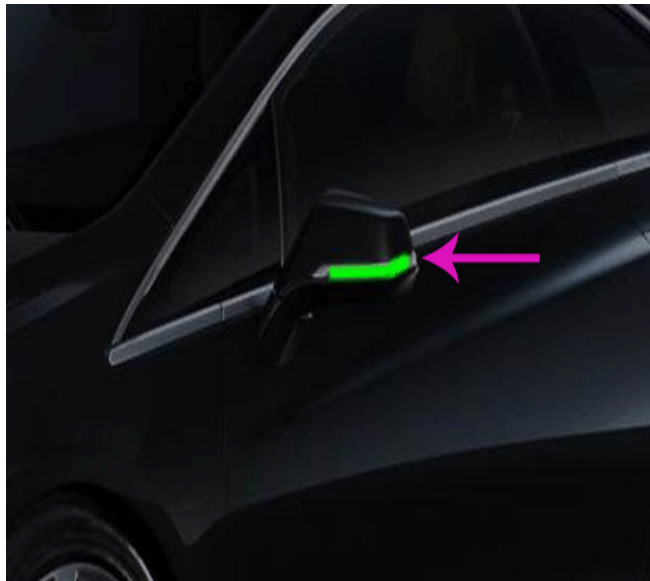

3665312

- **Solid green** – Battery is charging; charging is less than half complete
- **Fast flashing green** – Charging is more than half complete
- **Slow flashing green** – Charging is nearly complete
- **No light** – Charge is complete or not charging

Start Charging



3666104

The provided 120 V travel charge cord is located in the storage compartment under the cargo floor.

1. Place the vehicle in **P** (Park).



3666043

2. Select the **Charging** icon at the bottom of the Energy screen on the touch screen.
3. Review the selected **Charge Level** and **Charge Mode**.
4. Touch the **Green Text** if an increased Charge Level or different Charge Mode is desired.
5. Once the Charge Level and Charge Mode are selected, turn **OFF** the vehicle.

Note: The Charge Level selection automatically returns to the reduced level each time the vehicle is driven.

6. Remove the charge cord from the trunk and plug it into an electrical outlet. **DO NOT PLUG INTO AN EXTENSION CORD.** The charge cord indicator should be **green**. Where possible, secure the charge cord to the wall.



3666058

7. Press and release the rear edge of the charge port door, located just in front of the driver's door, to open the door. Plug the charge cord into the charge port.

The Charging Status Indicator on the instrument panel illuminates green and the horn chirps when properly connected. The side mirror lights illuminate green and may flash (if activated).

⇒ If the Charge Cord Theft Alert has been enabled, it is armed automatically when the vehicle is locked with the Remote Keyless Entry transmitter.

End Charging

1. Unlock the vehicle with the RKE transmitter to disarm the charge cord theft alert.



3666077

2. Unplug the charge cord from the vehicle by pressing the plug release button and close the charge port door.
3. Unplug the charge cord from the electrical outlet.
4. Properly stow the charge cord in the trunk.

Home Charging Station



3666136

Charging equipment with a rating of at least 240 V/20 A will provide the fastest charging time to recharge the high voltage propulsion battery. Contact your Cadillac dealer or an ELR Concierge representative for more information.

Transmission

The 4ET50 — RPO MKA, is a fully automatic front wheel drive transaxle, variable-speed, electronically controlled transmission. It consists primarily of a torque dampener assembly, an integral main and auxiliary fluid pump and housing, 1 planetary gear set, 2 friction (rotating) and 1 mechanical (stationary) clutch assemblies, a hydraulic pressurization and control system, and two internal electric motors. Drive motor generator A is 55 kW and drive motor generator B is 135 kW.

The torque dampener contains internal torsional springs, fluid, input shaft and a clutch. The torque dampener acts as a spring coupling to smoothly transmit power from the engine flexplate to the transmission. The dampener provides a mechanical direct drive coupling of the engine to the transmission. The clutch is applied during engine starting and stopping events.

The planetary gear set provides the Electrically Variable forward mode ratios and reverse. Changing ratios is fully automatic and is accomplished through the use of a transmission control module (TCM) located inside the transmission and the drive motor generator power inverter module located under hood. Both the TCM and the drive motor generator power inverter module receives and monitors various electronic sensor inputs and uses this information to vary the torque output at the optimum time based on throttle position.

The TCM commands shift solenoids and variable bleed pressure control solenoids to control torque timing and feel. All the solenoids, including the TCM, are packaged into a self-contained control solenoid valve assembly.

The main hydraulic system primarily consists of a gerotor-type pump, control valve body assemblies, dampener housing and case. The pump maintains the working pressures needed to stroke the clutch pistons that apply or release the friction components. These friction components, when applied or released, support the automatic ratios qualities of the transmission.

The hydraulic system also uses a secondary system and consists of an auxiliary pump located inside of the transmission. This is a gerotor-type pump, electric three phase High Voltage motor, electric harness, and control module. The control module is located inside of the drive motor generator power inverter module under the hood. This pump maintains working pressures when the engine is off.

The friction components used in this transmission consist of 3 multiple disc clutches. The multiple disc clutches combine with a planetary gear set and electric motor to deliver the different ratios, forward and reverse. The gear set then transfers torque through the final drive assembly.

The transmission may be operated in any of the following gear ranges:

- **P (PARK)** This position locks the wheels and prevents the vehicle from rolling either forward or backward.
- **R (REVERSE)** This position allows the vehicle to be operated in a rearward direction. This is done by the Drive Motor with Generator B and is electric.
- **N (Neutral)** In this position, the propulsion system does not connect with the wheels.

- **D (Drive)** Drive range should be used for all normal driving conditions for maximum efficiency and fuel economy. Drive range allows the transmission to operate in electrically variable modes providing various ratios and output torque.
- **L (Low)** This position is used for the feel of engine braking by maximizing regenerative braking once the throttle is lifted. While in this position the vehicle will slow quicker and use the drive motor generator B to more aggressively collect energy during a regenerative braking event.

Electrical Architecture

Global Diagnostic System 2 (GDS 2)

The 2014 ELR utilizes GM's Global A electrical architecture. This architecture requires the use of the Global Diagnostic System 2 (GDS 2) software and the Multiple Diagnostic Interface (MDI) module.

Dealerships requiring assistance in the process of installing GDS 2 and the MDI should contact the Techline Customer Support Center @1-800-828-6860 (English) or 1-800-503-3222 (French).

Keyless Access

Keyless Access System

The Keyless Access System enables operation of the doors without removing the Remote Keyless Entry transmitter from your pocket or purse by pressing the door handle touch pad at the rear edge of the door (from outside the vehicle), or pressing the door latch button on the inside pull handle (from inside the vehicle).

To use the Keyless Access feature, the transmitter must be within 3 ft (1 m) of the vehicle to operate the ELR.

- **Unlock:** With the transmitter within range of the door, press the touchpad at the rear edge of the door to unlock and open the door.
- **Lock:** If Passive Locking is turned **ON**, the vehicle will lock after all doors are closed and the transmitter is removed from the vehicle.
- **Key Release:** Press the button at the bottom of the transmitter to pull the door key out of the transmitter. Use the key to unlock the trunk.

Open the Doors Manually From Outside

If the vehicle's 12-volt battery is weak or disconnected, the door handle touch pads and door latch buttons may not operate. The doors can be opened from the outside manually.

To open the doors manually from outside the vehicle, perform the following:

1. Remove the door key from the transmitter.
2. Insert it into the lock cylinder above the license plate and turn it to open the trunk.



3670977

3. Pull the **door release tab** on the driver's side of the trunk, below the package shelf, to unlatch the doors.

Open the Doors Manually from Inside

Pull the **door release handle** on the floor next to each front seat.

Starting the Vehicle

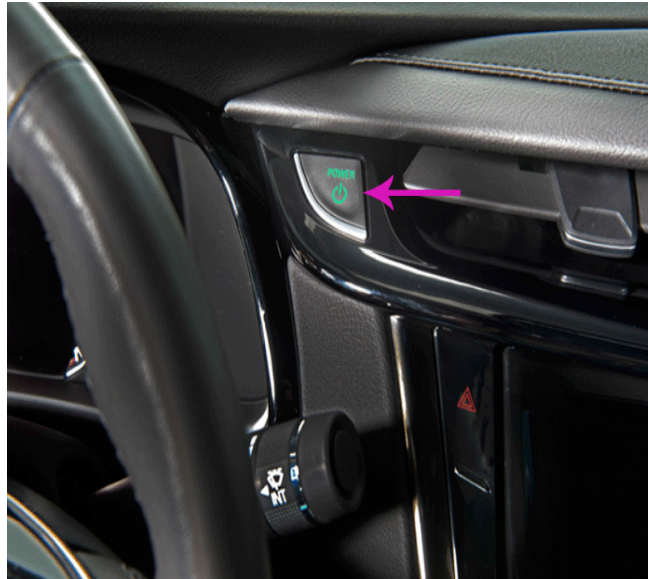

3661098

The transmitter must be in the vehicle to turn it **ON**. With the vehicle in **P (Park)** or **N (Neutral)**, press the brake pedal and then press the **POWER** button to turn **ON** the car. When **ON**, the instrument cluster will display an active battery and fuel gauge. The engine will start only if needed.

If the transmitter battery is weak or if there is interference with the signal that occurs in certain areas such as military zones, the DIC may display either of these messages: **NO REMOTE DETECTED** or **NO REMOTE KEY WAS DETECTED PLACE KEY IN TRANSMITTER POCKET THEN START YOUR VEHICLE.**

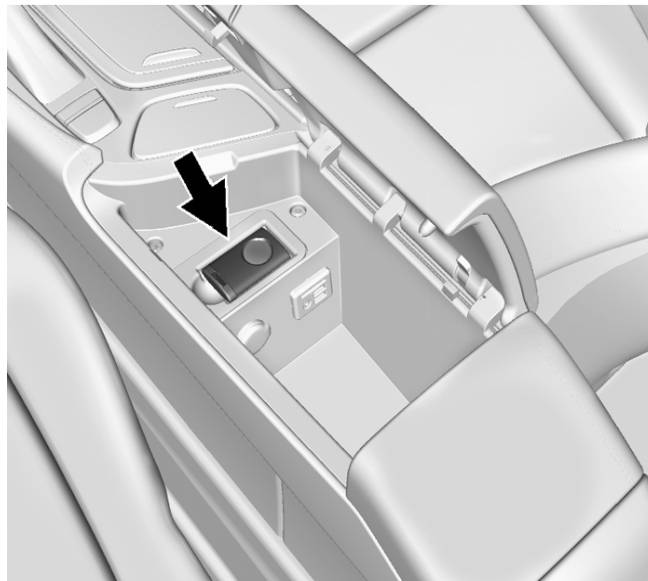

3661116

⇒ If either of these messages are observed, insert the transmitter, button side down, into the transmitter pocket located inside the center console and start the vehicle.

The key slides down out of the RKE transmitter and can be used for the trunk.

Instrument Cluster

The instrument cluster features an LCD screen that can be configured in four different themes.

- **Classic** displays basic information on speed, range and other operations.



3671084

- **Classic Enhanced** displays basic information plus driving efficiency and power usage information.
- **Modern** displays basic information on speed, range and other operations along with an efficiency ring that glows green to yellow based on driving efficiency.



3671086

- **Modern Enhanced** displays basic information and the efficiency ring plus additional power usage information.

Center Stack Infotainment Center Touch Screen and Controls

Touch Screen and Controls

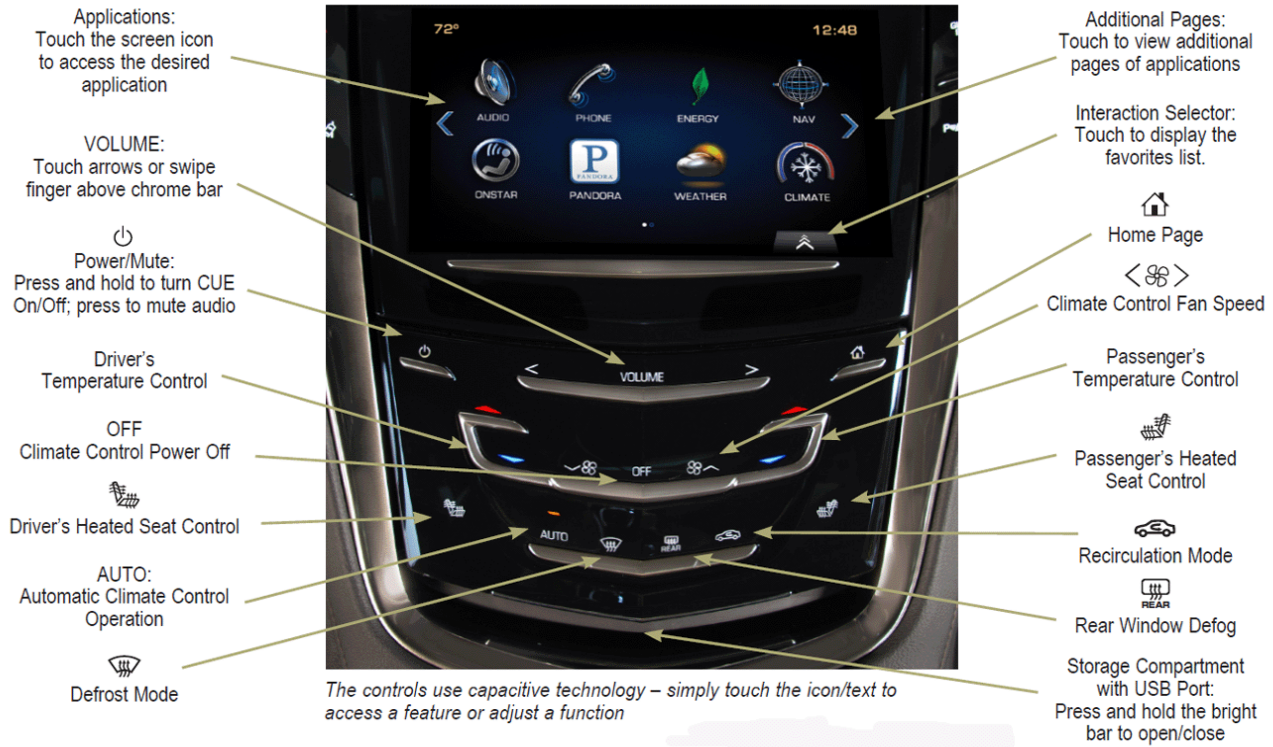

3657047

Cadillac User Experience (CUE) Infotainment System — USB Ports/SD Card Reader/AUX Jack



3670116

At the core of the car's intuitive technologies is the Cadillac User Experience (CUE) infotainment system that uses smartphone and tablet-influenced controls and commands to access information and entertainment data. CUE uses sharp, metallic icons with an illuminated blue glow on the 8-inch (203 mm) high-resolution color capacitive touch screen with haptic feedback that allows users to swipe and drag preferences, reconfiguration of Home screen icons, a Personalized app tray and the ability to save multiple rows of Favorites. Prominent Home screen apps can be dragged to the top row of the screen, making them easily accessible from a different page or application. New to

CUE is the **Energy Green Leaf** icon shown above. The screen's bottom row features a Favorites' bar that stores presets like Navigation Destinations, Phone Contacts and Radio Stations. Drivers can use their finger to drag this bar up, revealing three rows of Favorites, or slide the bar down to hide them. Bluetooth® connectivity with natural voice recognition and premium Bose® 10-channel audio system with active noise cancellation is standard. Bose® Active Noise Cancellation technology reduces the unwanted low frequencies created by the gas powered generator, transmission and other powertrain components by up to 20 dB, resulting in a quieter in-cabin experience.

CUE uses a Bluetooth or USB connection to link a smartphone, cell phone, USB flash drive or portable audio player/iPod® to the touch screen infotainment display. It offers a variety of entertainment options, including streaming audio from the Internet through a smartphone, and features enhanced hands-free voice control, music information and the ability to play music files from a USB flash drive or an SD media card. For information or assistance operating CUE, call 1-855-4-CUE-NOW (1-855-428-3669), or Go to: www.cadillac.com/cue In Canada, Go to: www.gm.ca/gm/english/vehicles/cadillac/infotainment/

The touch screen in the center stack can be used to display and adjust Infotainment, Vehicle Personalization and Climate Control settings. Use the controls on the center stack and the touch screen to access the various menus and settings. The center stack controls only need a light touch to operate and work best with bare hands. **Use the finger pad rather than the fingertip to minimize response time.** The controls work with most gloves but may take longer to respond. Remove gloves if necessary. In the screen menus, a check mark next to an item indicates it is: Selected/ON.

USB Ports/SD Card Reader/AUX Jack — Connecting Portable Audio Devices

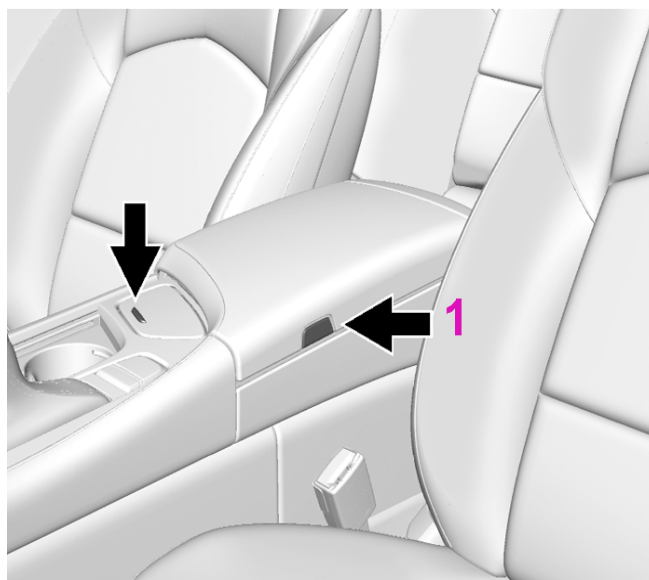

3656094

Two USB ports, an SD media card slot, and an auxiliary (AUX) audio input jack are located in the center console storage compartment. Connect an iPod®, iPhone®, MP3 player, a USB flash drive or a USB mass storage device to the USB ports or insert an SD media card into the card slot. Touch Media until the connected device is shown. CUE will read the device and build a list of voice commands. Press the button (1) on the driver side of the armrest to access the storage area beneath and the two USB ports, SD card reader, and AUX jack inside.

Bluetooth® System

The in-vehicle Bluetooth® system is standard on all models. The Bluetooth® system allows users with a Bluetooth® enabled cellphone to make and receive hands-free calls using the vehicle's audio system, microphone and controls. The Bluetooth® enabled cellphone **MUST** be paired with the vehicle Bluetooth® system **BEFORE** it can be used in the vehicle.

Not all Bluetooth® cellphones will work with the vehicle's Bluetooth® system or support all functions. Bluetooth® enabled cellphones will be tested for vehicle compatibility and a Feature Compatibility list will be published on the Bluetooth® website.

Notice: To Canadian Dealers, the following is a United States website that is presented in English only. Canadian carriers are not listed directly, but when identified, the phone model functions are similar.

For more information Go to: <http://www.onstar.com/web/bluetooth>

On the Bluetooth® Home page, Go to: Pair Your Phone > Select Vehicle > Select Make > Select Cadillac > Select Year > Select 2014 > Select Model > Select ELR > Select Radio (the vehicle's radio system) > Select Submit > Select Compatible Devices > Select Your Device

Power Flow Screens

The Power Flow screens indicate the current system operating condition, showing the power flow between the high voltage propulsion battery, electric drive unit and engine. Each component is highlighted when it is active.

To view the Power Flow screens, press the **Leaf** button on the infotainment display and then press the Power Flow button at the bottom of the touch screen. The Power Flow screens indicate the current system operating condition. The screens show the energy flow between the engine, electric drive unit, and high voltage battery. These components will be highlighted when they are active.



3666451

- **Battery Power:** Battery is active with energy flowing to the wheels.
- **Engine Power:** Engine is active with energy flowing to the wheels.
- **Engine and Battery Power:** Both the engine and battery are active with energy flowing to the wheels.
- **Battery Power:** Vehicle is stationary in electric mode and no power is flowing to the wheels.
- **Engine Power:** Vehicle is stationary in extended range mode and no power is flowing to the wheels.
- **Engine and Regen Power Recovery:** Engine is active. Power from the wheels returns to the battery during regenerative braking or coasting.

For more information, refer to > Owner Manual > Instruments and Controls > Information and Displays > Power Flows

Drive Modes and PRNDL Selection



3666387

There are four operating Drive Modes. The vehicle will always default to Tour Mode on every key cycle. Press the Drive Mode button on the center console to scroll through a menu of operating modes. After three seconds, the highlighted mode will become active in the Instrument Cluster.

- **Tour Mode:** Use Tour Mode when possible in normal driving conditions for efficient operation.
- **Sport Mode:** Use Sport Mode when more responsive acceleration is desired from a stop. Sport Mode provides more responsive acceleration than Tour Mode, but can reduce efficiency.
- **Mountain Mode:** Use Mountain Mode **prior** to climbing long, steep grades in mountainous areas. Be sure to engage Mountain Mode before starting to climb. Mountain Mode reduces electric range and power, but may be needed to maintain speeds above 60 mph (97 km/h) when climbing grades of 5% or greater.
- **Hold Mode:** Use Hold Mode on a trip where all or most of the electric charge will be depleted. Use Hold Mode mainly during highway or high-speed driving to maximize both electric vehicle miles and fuel efficiency.
- **L (Low)** Use L (Low) in heavy stop-and-go traffic or when traveling downhill. L requires less brake pedal application and provides a controlled, efficient way to slow the vehicle down, by maximizing regenerative braking.

Climate Control

Climate Control Touch Screen



3667432

The fan, air delivery mode, driver and passenger temperatures, A/C mode, and SYNC settings can be controlled by pressing the **CLIMATE** icon on the infotainment home screen (shown) or the climate button in the touch screen application tray. A selection can then be made on the front climate control page that is displayed.

Climate Control Touch Screen Controls — Climate Modes



3670498

Optimal efficiency is achieved with the heat, air conditioning and fan turned **OFF**.

Touch the climate mode settings to adjust the impact the climate control system has on the vehicle's efficiency. The most efficient Mode operation is in the following order:

- **MIN** Electric cabin heating/cooling is **OFF**.
- **ECO** Limits cabin heating/cooling to balance comfort with energy use.
- **MAX** Provides the most cabin heating/cooling but uses the most energy.

Use the heated seats and heated steering wheel to reduce the demand on the cabin heating system. Heating the seats and steering wheel uses less energy than heating the vehicle interior.

Heating and Air Conditioning

Heating System

The heating system uses the engine and a high voltage heater to provide heat to the passenger compartment. The high voltage heater is used when the engine is not running and passenger compartment heat is requested. The high voltage heater provides different levels of heat depending on the amount of heat needed and outside temperature. The HVAC Control Module turns on the coolant pump and monitors the temperature sensors in the passenger compartment, outside air, engine radiator, high voltage heater and the engine to determine the position of the coolant flow control valve and if the high voltage heater is needed. Passenger compartment heat is provided by air flowing through the heater core. The heater core is heated by coolant from either the engine or the high voltage heater. The engine cooling system circulates a **50/50 mixture of Dex-cool and deionized water**.

Air Conditioning

The 300 V high voltage electric A/C compressor is a self contained high voltage inverter, electric motor, and direct coupled compressor. The electric A/C compressor has the ability to run and provide cooling performance even when the vehicle engine is **not running**. This feature enables the electric A/C compressor to run at a speed independent of the engine. The electronic climate control module and the Vehicle Integration Control Module (VICM) will command the electric A/C compressor to a speed necessary to maintain a desired cooling level rather than cycle the electric A/C compressor **ON** and **OFF**.

The A/C system uses R-134a refrigerant which is a gas at very low temperatures and can transfer heat from the passenger compartment and high voltage battery to the outside air. The A/C system also uses POE (Polyol Ester) refrigerant oil instead of PAG (Polyalkylene Glycol) because it is less hygroscopic. The A/C compressor features a high RPM scroll compressor that is pulse width modulated. During conditions with high ambient temperatures and

high humidity, the driver may notice a unique high-pitched sound from the compressor. This is considered a normal characteristic, and it may be heard when the vehicle is stopped or at low speeds. The A/C compressor is serviced as a unit.

Driver Assistance Systems

The driver assistance features are based on a "control and alert" strategy that helps identify potential collision situations and intervenes when a collision threat appears more imminent, employing visual, audible and/or tactile (vibration) alerts.

The following four Driver Assistance Systems are standard equipment on the ELR:

- **Lane Departure Warning** When crossing a detected lane marking without using a turn signal, a visual alert flashes on the instrument cluster and the left or right side of the driver's seat pulses. See Safety Alert Seat. Press the Lane Departure Warning button on the left side of the CUE touch screen to turn the system **ON** or **OFF**. The button illuminates when the system is **ON**.
- **Forward Collision Alert** When approaching a vehicle directly ahead too quickly, a visual alert flashes on the windshield and the driver's seat pulses. See Safety Alert Seat. Press the Collision Alert button or the Follow Distance Gap button if equipped with Adaptive Cruise Control on the left side of the steering wheel to set the alert timing.



3610803

- **Safety Alert Seat** Subtle seat cushion vibration pulses, left or right, or simultaneously, to alert the driver of potential hazards. Audible notification may be selected instead of Safety Alert Seat vibration notification; to change the setting, go to Collision/Detection Systems in the Vehicle Settings menu.



2900694

- **Rear Vision Camera** When the vehicle is in **R** (Reverse), a view of the area behind the vehicle appears on the CUE touch screen.

In addition to the standard equipment, the following Driver Assistance Systems are included in the Luxury Package:

- **IntelliBeam®** Automatically turns the high-beam headlamps **ON** or **OFF** depending on traffic conditions.
- **Side Blind Zone Alert** When a vehicle is detected in a side blind spot area, a warning symbol displays on the side mirror. To turn **OFF** the system, go to Collision/Detection Systems in the Vehicle Settings menu.



2866857

- **Rear Cross Traffic Alert** Warns of traffic coming in either direction by displaying a visual alert on the Rear Vision Camera screen, and the left or right side of the driver's seat pulses. See Safety Alert Seat. To turn the system **ON** or **OFF**, go to Collision/Detection Systems in the Vehicle Settings menu.
- **Adaptive Cruise Control** If a vehicle is detected ahead, the vehicle accelerates or brakes moderately to maintain the selected following gap. If driver action is required, a visual alert flashes on the windshield and the driver's seat pulses. See Safety Alert Seat. Press the Follow Distance Gap button on the left side of the steering wheel to set a following gap.
- **Automatic Collision Preparation** Included with Adaptive Cruise Control, this feature prepares the brakes or applies the brakes if an emergency collision appears immediate or the driver does not react to previous alerts.

Aerodynamic Enhancements

The ELR offers improved aerodynamics for better range and efficiency. This includes a lower front air dam, low flow front grill, lower grill shutters, rear spoiler and low rolling resistance tires. It is normal for the flexible air dam to occasionally contact the road surface on steep driveways or parking structures. It is also important that the vehicle is not pulled against tall curbs to prevent fascia and air dam contact.

Customers may also comment on wind buffeting when driving at higher speeds with a window down. This is a result of the aerodynamic shape of the vehicle to increase range and efficiency.

Airbags

Airbags are designed to supplement the protection provided by safety belts.

Notice: The vehicle is equipped with the following airbags:

- A frontal airbag for the driver.
- A frontal airbag for the front outboard passenger.
- A knee airbag for the driver.
- A knee airbag for the front outboard passenger.
- A seat-mounted side impact airbag for the driver.
- A seat-mounted side impact airbag for the front outboard passenger.
- Seat-mounted side impact airbags for the second row outboard passengers.
- A roof-rail airbag for the driver and the passenger seated directly behind the driver.
- A roof-rail airbag for the front outboard passenger and the passenger seated directly behind the front outboard passenger.

Tire Inflator Module

The ELR features a tire inflation kit instead of a spare tire. In the event of a flat tire, the tire sealer should be used in combination with the air compressor to inflate the tire. The tire inflation kit is located in the rear hatch under the storage compartment, where the spare tire is normally located. It is important to note that there is no spare tire, and the tires are not run-flat tires. Any tire or wheel damage that is not repairable with the tire sealer and air compressor requires that the vehicle be flat-bed carried to the nearest tire repair facility.

12 V Absorbed Gas Mat (AGM) Battery

Notice: The 12 V battery used in the ELR is an Absorbed Gas Mat (AGM) type battery that requires different charging voltages than conventional lead acid batteries. The essential tool (GR-8) EL-50313 has this algorithm built in. You must select AGM when prompted or damage to the battery will result.

The Cadillac ELR uses the 12 V battery to "wake up" and initialize control modules. If the vehicle does not power up, verify that the 12 V battery is sufficiently charged to allow for all of the control modules to wake up and initialize. The vehicle does not use a traditional 12 V starter motor to crank the ICE. A much more powerful 300 V motor, drive motor 1, located within the transmission is utilized to crank the ICE. Drive motor 1 can rotate the ICE to an operating speed of 800 RPM within just a few hundred milliseconds.

To prevent excessive drain on the 12 V system and a potential no start condition, it is recommended that customers allow the vehicle to remain in **Run** when listening to the radio for extended periods of time. It is important that when exiting the vehicle, ensure the system is powered **OFF** by verifying the instrument cluster is no longer active and there is no power steering.

Jump Starting the ELR 12V Battery

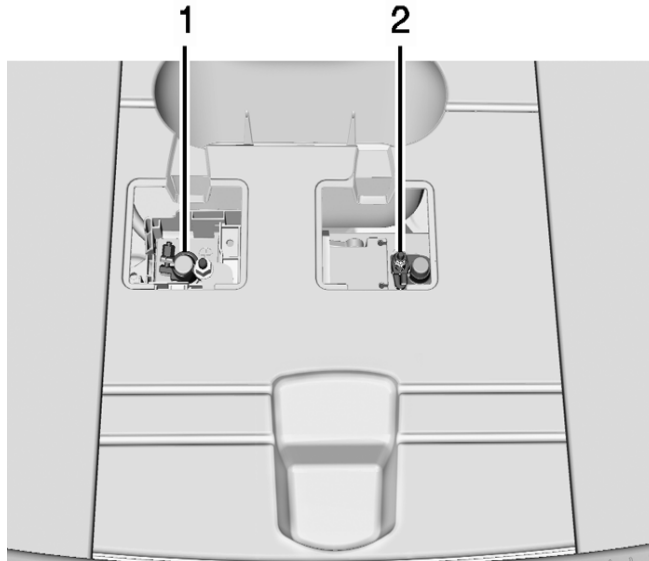

3671275

1. Positive (+) Terminal
2. Negative (-) Terminal

If the ELR will not start, the 12-volt battery may be run down. Use the key to open the trunk. To jump start the ELR, jumper cables are connected directly to the positive (+) and negative (-) terminals on the 12-volt battery in the rear cargo area. The other vehicle used to jump start the ELR must have a 12-volt battery with a negative ground system. Park both vehicles close enough so that the jumper cables can reach both vehicles' positive (+) and negative (-) terminals. When jump starting, **the vehicles must not touch each other**. It could cause an unwanted ground connection that could damage both vehicles' electrical systems.

Low Profile Lift Arms System — Hoist Contact Lift Points

The use of a **LOW PROFILE LIFT ARMS SYSTEM** may be required to avoid unwanted contact with the vehicle's body and structure depending on the lifting equipment being used. Refer to the hoist manufacturer's recommendation for their applications of low profile lift arms system for their lifting equipment.



3670390

This is a view of the proper front hoist contact lift point.



3670407

This is a view of the proper rear hoist contact lift point.

Before setting or raising the vehicle, in order to determine the proper front and rear hoist contact lift points, refer to the preceding graphics.

Towing A Disabled Vehicle

Notice: Please advise the customer to share this information with their towing provider.

Towing the Vehicle / Flatbed Car Carrier

Notice: Incorrectly towing a disabled vehicle may cause damage. A wheel lift tow truck could damage the vehicle. The damage would not be covered by the vehicle warranty.

Have the vehicle towed on a **flatbed car carrier**. Ramps are required for the front fascia to clear the flatbed. North American vehicles **do not** have a tow eye. The ramp height should be approximately 4 in (102 mm). Lower the flatbed onto the set of ramps.

To load a vehicle onto a flatbed carrier perform the following:

1. The vehicle **MUST** be on a **flat surface**.
 - ⇒ If the vehicle is parked off the shoulder of the road, at an angle that it cannot be pulled onto a flatbed, a hook/chain can be placed into either of the front torque box openings to pull the vehicle onto a flat surface. Make sure that the tow chains do not come in contact with the rocker panel or the front fascia.
2. The front tires must be properly inflated. If necessary, move a rear tire to the front to replace a flat or damaged tire.

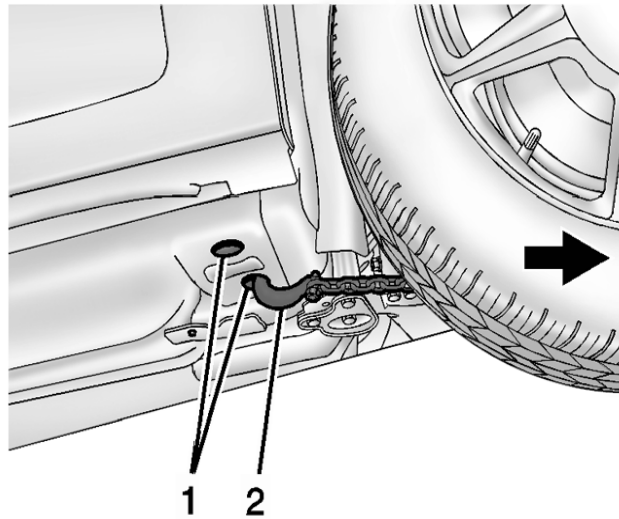

3671775

3. Place the tow chain hooks (2) into one of the torque box openings (1) behind the front wheels.

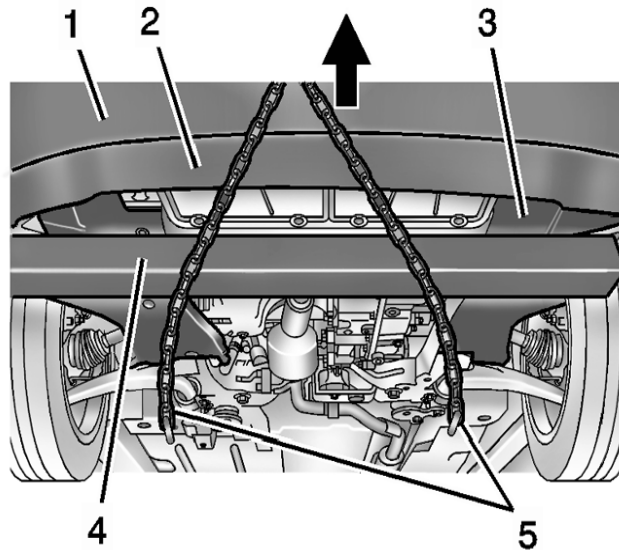

3671783

4. Place a 4 ft (1.2 m) X 4 in (102 mm) wood beam (4) under the front cradle crossmember (3), and on top of both tow chains (5) to ensure the tow chains do not come into contact with the front fascia (1). Try to minimize the contact of the chains with the flexible air dam (2).

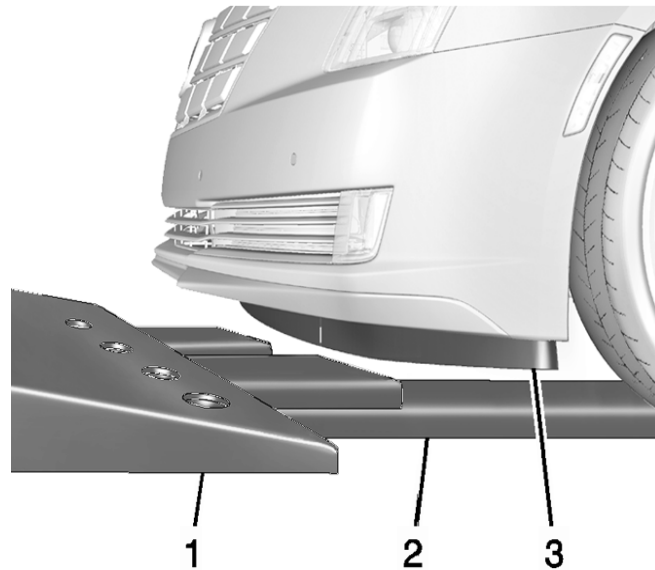

3671805

5. Ramps (2) are **required** for the front fascia (3) to clear the flatbed (1). The ramp height should be approximately 4 in (102 mm). Lower the flatbed onto the set of ramps.
6. After the front tires are on the flatbed adjust the flatbed upward to provide additional clearance between the air dam, fascia, and flatbed.
7. When the fascia has enough clearance to clear the flatbed, lower the flatbed, and finish pulling the vehicle onto the flatbed.
8. Use the proper nylon strap harnesses around the tires to secure them to the flatbed car carrier.

Trailer Towing

Trailer Towing

The vehicle is neither designed nor intended to tow a trailer or another vehicle.

Warranty Information — Roadside Assistance — Concierge and Cadillac Shield — Cadillac Online Owner Center — Cadillac Owner Centre (Canada)

Warranty Information

The Cadillac ELR has multiple warranty coverages as follows:

- 3 Year OnStar® Directions and Connections with Turn-by-Turn Navigation Included.
- 4 Year/50,000 mile (80,000 km) bumper to bumper United States or Canadian Base Warranty Coverage.
- 4 Year/50,000 mile (80,000 km) Cadillac Premium Care Maintenance Program
- 6 Year/70,000 mile (110,000 km) Powertrain Warranty.
- 8 Year/100,000 mile (160,000 km) High Voltage Battery and EREV Component Warranty.
- 10 Year/150,000 mile (241,400 km) High Voltage Battery and EREV Component Warranty (California Emission States).
- 15 Year/150,000 mile (241,400 km) PZEV emissions warranty (California Emission States).

Roadside Assistance

Roadside Assistance provides every Cadillac owner with the advantage of contacting a Cadillac advisor and, when appropriate, a Cadillac-trained dealer technician who can provide on-site services, including towing service, battery jump-starting, lock-out service, fuel delivery and flat tire assistance. Services are provided for up to 6 Years/70,000 miles (110,000 km), whichever occurs first.

For Roadside Service call:

- U.S.: 1-800-224-1400.
- Canada: 1-800-882-1112.
- Text Telephone (TTY) Users (U.S. Only): 1-888-889-2438.
- Service is available 24 hours a day, 365 days a year.

Roadside Assistance and OnStar®

If you have a current OnStar® subscription, press the OnStar® button and the vehicle will send your current GPS location to an OnStar® Advisor who will speak to you, assess your problem, contact Roadside Assistance and relay your exact location so you will get the help you need. ELR owners will get access to OnStar® services like Turn-by-Turn Navigation, Hands-Free Calling, Vehicle Diagnostics, Automatic Crash Response and Stolen Vehicle Assistance. OnStar's premium Directions & Connection package comes standard on the Cadillac ELR for one year. To learn more about OnStar® services, press the OnStar® button, refer to your Owner Manual, call 1-888-466-7827 or Go to: www.OnStar.com (United States). In Canada, Go to: www.OnStar.ca

Concierge and Cadillac Shield

Should you need to ask a question, make a comment, or request additional information about your Cadillac ELR, contact your Dedicated Cadillac Concierge Team that has been trained in White Glove Service — Call 1-855-4-CAD-ELR (1-855-422-3357). In Canada, contact Cadillac Customer Care by calling 1-888-446-2000.

Cadillac Online Owner Center (United States)

Go to: www.my.cadillac.com for access to the Cadillac Owner Center, which features online Owner Manuals, Warranty Manuals, maintenance information, service records, and more.

Cadillac Owner Centre (Canada)

Go to: www.cadillacowner.ca to chat live with online help representatives, locate owner resources such as lease-end, financing, and warranty information. Retrieve favorite articles, quizzes, tips, and multimedia galleries organized into the Features and Auto Care Sections. Download Owner Manuals and find Cadillac recommended maintenance services.

Cadillac ProductSource Videos United States

The Cadillac ProductSource videos are accessed through the GM Center of Learning website. Go to: <https://www.gmproductsource.com/gm.aspx>

If you experience difficulties, contact the Center of Learning Help Desk. Go to: www.centerlearning.com

Cadillac ProductSource Launch & Product Knowledge Video Training in Canada

In Canada, please log in through Global Connect. Go to: "GM Pro ProductSource" Training on the Canadian LMS

Required Product Training

The majority of the systems found on the Cadillac ELR are taught in GM's core curriculum from a conceptual theory and operation perspective.

To access **all** of the available Training Courses visit the following website:

- In the United States Go to: www.centerlearning.com
- In Canada Go to: www.gmprocanada.com

Notice: Once the initial Required Service Training Courses are completed, Technicians **MUST** enroll (or be wait listed) in order to participate in the Required #18420.06H-R2 Hands-On Training Course and the #18420.10D-R2 Virtual Classroom Training (VCT) Course.

Required Service Training Courses — United States

Required Course Name	Course Number and Description
Cadillac ELR Introduction	#18420.20W Cadillac ELR Introduction (Web-Based)
EREV Introduction and Safety	#18420.01W-R2 EREV Introduction and Safety (Web-Based)
High Voltage Energy Storage Systems	#18420.02W-R2 High Voltage Energy Storage Systems (Web-Based)
EREV High Voltage (HV) Disable Procedure	#18420.02T1-R2 (Web-Based)
Advanced Technology Vehicle Power Electronics	#18420.03W-R2 Advanced Technology Vehicle Power Electronics (Web-Based)
Advanced Technology Transmission	#18420.04W-R2 Advanced Technology Transmission (Web-Based)
Advanced Technology Vehicle Supporting Systems	#18420.05W-R2 Advanced Technology Vehicle Supporting Systems (Web-Based)

Required Service Training Courses — United States (cont'd)

Required Course Name	Course Number and Description
Electric Vehicle Systems Diagnosis and Service	#18420.06D1-R2 Electric Vehicle Systems Diagnosis and Service (VCT)
Electric Vehicle Systems Diagnosis and Service — Session 2	#18420.06D2-R2 Electric Vehicle Systems Diagnosis and Service — Session 2 (VCT)
You MUST complete the above prerequisites in order to enroll (or be wait listed) and participate in the following courses:	
Electric Vehicle and Transmission: Diagnosis and Service	#18420.06H-R2 Electric Vehicle and Transmission: Diagnosis and Service (Hands-On Training)
PRIOR to servicing the HV battery, the Technician would need to complete the following course:	
High Voltage Battery Internal Service	#18420.10D-R2 High Voltage Battery Internal Service (VCT)

Notice: Once the initial Required Service Training Courses GMCL are completed, Technicians MUST enroll (or be wait listed) in order to participate in the remaining courses.

Required Service Training Courses GMCL — Cadillac ELR Training Path — Canada

Required Course Name	Course Number and Description
Cadillac ELR Introduction	#18420.20W Cadillac ELR Introduction (Web-Based)
EREV Introduction and Safety	#18420.01W EREV Introduction and Safety (Web-Based)
High Voltage Energy Storage	#18420.02W High Voltage Energy Storage (Web-Based)
EREV High Voltage Disable Procedure	#18420.02T1 EREV High Voltage Disable Procedure (Web-Based)
Advanced Technology Vehicle Power Electronics	#18420.03W Advanced Technology Vehicle Power Electronics (Web-Based)
Advanced Technology Vehicle Transmission	#18420.04W Advanced Technology Vehicle Transmission (Web-Based)
Advanced Technology Vehicle Supporting Systems	#18420.05W Advanced Technology Vehicle Supporting Systems (Web-Based)
Electric Vehicle Systems Diagnosis and Service — Session 1	#18420.05D1 Electric Vehicle Systems Diagnosis and Service — Session 1 (VCT)
Electric Vehicle Systems Diagnosis and Service — Session 2	#18420.05D2 Electric Vehicle Systems Diagnosis and Service — Session 2 (VCT)
You MUST complete the above prerequisites in order to enroll (or be wait listed) and participate in the following courses:	
Electric Vehicle Battery Diagnosis and Service	#18421.16H Electric Vehicle Battery Diagnosis and Service (Hands-On Training)
Electric Vehicle Supporting Systems Diagnosis and Service	#18422.16H Electric Vehicle Supporting Systems Diagnosis and Service (Hands-On Training)
PRIOR to servicing the HV battery, the Technician would need to complete the following courses:	
EREV Battery Internal Servicing	#18421.05D-OD EREV Battery Internal Servicing (On Demand VCT)
High Voltage Battery Section Diagnosis & Servicing	#18421.09D High Voltage Battery Section Diagnosis & Servicing (VCT)

Special Tools

Notice: As communicated in the ELR Participation Agreement, dealers must have the required special tools to service the EREV system. Commencing in early December 2013, specific ELR dealers (that have not previously been shipped EREV special tools) will have 2014 Cadillac ELR Essential Tools & Chargers shipped to them.

Tool #	Description
EL-49976	Battery Pack Lifting Fixture (On-Car Service)

Tool #	Description
EL-50554	Tester, Voltage Disable Assurance Harness Set (On-Car Service)
EL-50209	Covers, Battery Connector (On-Car Service)
DT-50301	Installer, Axle Seal (Lt and Rt), and Ext Housing Axle Bearing (On-Car Service) & (Unit Repair - Drive Unit)
DT-47800-10	Kit, Bolts and Spacers, Shim Selection (Unit Repair - Drive Unit)
DT-49098	Remover, Input & Output Clutch Pack Retaining Ring (Unit Repair - Drive Unit)
DT-49229	Installer, Transfer Shaft Bearings (Conv Hsg Side & Case Side) & Output Clutch Pack (Center Support) Bearing (Unit Repair - Drive Unit)
DT-49230	Remover, Transfer Shaft Bearing Set (Conv Hsg Side & Case Side) & Output Carrier Brg (Unit Repair - Drive Unit)
DT-49261	Installer, Input Shaft Seals (2 Teflon® Rings) (Unit Repair - Drive Unit)
DT-49263	Installer, Diff Brg Cups, Pump & Sun Gear Bearings (Unit Repair - Drive Unit)
DT-49266	Remover, Differential Bearing Cup, Case Side (Unit Repair - Drive Unit)
DT-49468	Installer, Output Clutch Housing Retaining Ring (Unit Repair - Drive Unit)
DT-49830	Installer/Pilot Differential Bearing-used w/DT-47928-2 Installer (Unit Repair - Drive Unit)
J-22928-B	Installer, Drive Motor Rotor Bearing (On-Car Service) & (Unit Repair - Drive Unit)
DT-50302-A	Lifter, Rotor & Stator Assembly (On-Car Service) & (Unit Repair - Drive Unit)
DT-50834	Sizer, Resolver B Teflon® Seal (Unit Repair - Drive Unit)
EL-48571-A	Pinout Box, Battery (Battery Diagnostics)
EL-48571-25	Harness, Battery Pin-out Box Adapter (Battery Diagnostics)
EL-50211	Harness, Low Voltage Jumper (Battery Diagnostics)
EL-50812	Plugs, Battery Leak Test (Battery Internal Controls Service)
GE-50385	Adapter, Battery Pack Coolant Passage Pressure Test (Battery Internal Controls Service)
GE-50389	Adapter, Quick Connect Assembly (Battery Internal Controls Service)
EL-48264-A	Adapter Bar, Battery Section Lifting (Battery Pack Section Service)
EL-50115	Battery Section Lifting Adapters (Battery Pack Section Service)
EL-50325	Covers, Battery HV Internal Terminal Post (Battery Pack Section Service)
EL-50332	Tool, Battery Load Leveling (Battery Pack Section Service)

Tool #	Description
EN-48488	V-Belt Tensioner Tool (1.4L Engine Service)
EN-49941	Piston Retaining Clip Compressor (Unit Repair - 1.4L Engine)
KM-235-6	Crankshaft Rear Main Seal Protector (1.4L Engine Service)
KM-658-1	Crankshaft Rear Main Seal Installer (1.4L Engine Service)
KM-952	Crankshaft Locking Pin (1.4L Engine Service)
KM-953-A	Camshaft Timing Tool (1.4L Engine Service)
KM-955	Locking Pins, V-Belt and Timing Tensioners (1.4L Engine Service)
KM-960	Crankshaft Front Oil Seal Installer (1.4L Engine Service)
EN-49979	Balancer Holder (1.4L Engine Service)
KM-958	Valve Stem Seal Installer (1.4L Engine Service)
EN-49977	Camshaft Timing Tool (1.4L Engine Service)
CH-49459	Rear Axle Bushing Tool (Chassis Service)
CH-50342	Bushing Replacement Hardware Kit (Chassis Service)
KM-906-14	Front Cradle Bushing Adapter (Chassis Service)
KM-906-42	Front Cradle & Rear Axle Bushing Adapter (Chassis Service)

Quality Pre-Delivery Inspection (PDI) — Completely Satisfied Delivery System (CSDS)

Please be sure to review the Pre-Delivery Inspection (PDI) and Completely Satisfied Delivery System (CSDS) forms published for this vehicle. There are several Special Inspection Items highlighted for this vehicle. Additionally the CSDS form has important customer education items that have been identified during the Captured Test Fleet process.

- United States Dealers should report any product issues via a Field Product Report (FPR). Refer to the latest version of Corporate Bulletin Number 02-00-89-002 Information for Dealers on How to Submit a Field Product Report.
- Canadian Dealers should report any product issues via a Product Information Report (PIR). Refer to the latest version of Corporate Bulletin Number 10-00-89-006 Information for Dealers on How to Submit a Product Information Report.

Bluetooth® is a Registered Trademark of Bluetooth SIG, Inc.

Bose® is a Registered Trademark of the Bose Corporation

dexos 1™ is a Trademark of General Motors LLC

iPad® is a Registered Trademark of Apple, Inc.

iPhone® is a Registered Trademark of Apple, Inc.

iPod® is a Registered Trademark of Apple, Inc.

Intellibeam™ is a Trademark of General Motors LLC

OnStar® is a Registered Trademark of OnStar LLC

OnStar® RemoteLink™ is a Trademark of OnStar LLC

Pandora® is a Registered Trademark of Pandora Media, Inc.

"XM RADIO® is a Registered Trademark of Sirius XM Radio Inc.."

Regen On Demand™ is a Trademark of General Motors LLC

StabiliTrak® is a Registered Trademark of General Motors LLC

DuPont™ and Teflon® are Trademarks or Registered Trademarks of E. I. du Pont de Nemours and Company or its Affiliates.