



Service Bulletin

File in Section: -

Bulletin No.: P11022

Date: July, 2013

PRELIMINARY INFORMATION

Subject: 2014 Cadillac ATS New Model Features

Models: 2014 Cadillac ATS
Equipped with Engine 2.0L RPO LTG, 2.5L RPO LCV or 3.6L RPO LFX
Equipped with 6-Speed 6L45 Automatic Transmission RPO MYA or 6-Speed Manual
Transmission TREMEC (TR3160) RPO M3L
Equipped with Rear Wheel Drive or All Wheel Drive

Bulletin Purpose



3533091

The purpose of this bulletin is to help the Service and Sales Department personnel become familiar with the Model Year 2014 Cadillac ATS vehicle enhancements.

About the Vehicle

The ATS is available in four distinct equipment packages: Standard, Luxury, Performance and Premium.

The ATS is available with a choice of three powerful and efficient direct-injected engines coupled with a 6-speed automatic or a 6-speed manual transmission (2.0L Turbo only) and standard rear-wheel-drive (RWD) or available all-wheel-drive (AWD).

Cadillac Premium Care Maintenance / New Vehicle Limited Warranty

The ATS model comes with the Cadillac Premium Care Maintenance program. It is a program designed to provide the customer with peace of mind by covering select required maintenance during the first four years or 50,000 miles (80,000 km) of the vehicle's operation. It aligns with the terms of our 4-years or 50,000 mile bumper-to-bumper New Vehicle Limited Warranty, in Canada 4-years 80,000 km, and is fully transferable.

Cadillac Premium Care Maintenance covers routine maintenance during the first 4-years or 50,000 miles (80,000 km) and includes the following:

- Oil changes based on the Oil Life Monitoring System.
- Tire rotation every 7,500 miles (12,000 km).

- Engine air cleaner filter replacement.
- Passenger compartment air filter replacement.
- Multi-Point Vehicle Inspection (MPVI).

Transferable Powertrain Limited Warranty / Roadside Assistance and Courtesy Transportation

All Cadillac models come backed with a 6-year or 70,000 mile (110,000 km) Transferable Powertrain Limited Warranty. This means if the owner needs warranty repairs to their engine, transmission or drive system in the first 6-years or 70,000 miles (110,000 km), Cadillac has them covered.

If the vehicle needs service, there is 24/7 Roadside Assistance and Courtesy Transportation with the same coverage of 6-years or 70,000 miles (110,000 km).

Available Product Training

The majority of the systems found on the Cadillac ATS are taught in GM's core curriculum from a conceptual theory and operation perspective.

To access **all** of the available ATS Training Courses visit the following website:

- In the United States go to > www.centerlearning.com
- In Canada go to > www.gmprocanada.com

Training Course Name and System RPO - Course Number and Description

Course Name - System RPO	Course Number and Description
Base Curriculum	#16041.09W Battery, Charging and Starting Systems #16044.21 Engine Performance #16044.16 GM Powertrain Performance #16048.25W-R3 Multiple Diagnostic Interface (MDI) Familiarization #16048.30H-R2 Global Diagnostic System 2 (GDS 2) Overview - Hands On #16048.30W-R2 Global Diagnostic System 2 (GDS 2) Overview #16050.12D Camshaft Position Actuator System and Active Fuel Management (VCT) #18043.01W-R4 Electrical / Electronics Stage 1 #18043.02W-R4 Electrical / Electronics Stage 2 #18043.03W-R3 Electrical / Electronics Stage 3 #18044.20 GM Global Electrical System #13044.20 GM Chassis Control Systems #15045.18 GM Braking Systems #16048.27V GDS 2 Diagnostics (Canada) #16039.16H GDS 2 Certification (Canada) #17041.56 Automatic Transmission Operation, Diagnosis and Service #14043.17 Passenger Car All-Wheel Drive (Base Curriculum)
Air Bags - RPO AYF or AYG Depending on the Equipment Package - This Vehicle Comes Equipped With Either: - 8 Air Bags RPO AYG - 10 Air Bags RPO AYF	#12340.10 Dual Stage Air Bag System #22048.42 GM Safety Systems
Engine Control-Stop/Start System - RPO KL9	#16040.30W Stop/Start System
HVAC System - Air Conditioning - RPO CJ2	#11044.04 HVAC Systems #11044.05 HVAC Systems and Operation.
Transaxle / Transmission	#17041.48W Automatic Transmission Gearsets
Engine - 2.0L Turbocharged DOHC with Spark Ignition Direct Injection (SIDI), Variable Valve Timing (VVT) Engine - 2.5L DOHC with Spark Ignition Direct Injection (SIDI), Variable Valve Timing (VVT) Engine - 3.6L DOHC with Spark Ignition Direct Injection (SIDI), Variable Valve Timing (VVT)	#16043.52 Engine Mechanical Diagnostics and Measurements #16044.21 GM Powertrain Performance #16044.20 SIDI - Virtual Classroom Training (VCT) #16440.17D Engines (VCT): New and Updated for RPO's LCV and LTG

Training Course Name and System RPO - Course Number and Description (cont'd)

Course Name - System RPO	Course Number and Description
Transmission - 6-Speed Automatic, Electronically Controlled with Overdrive Transmission - 6-Speed TREMEC Manual F46 Chassis AWD Transmission	#17041.65 6-Speed Automatic Transmission Mechanical Service #17041.56 Automatic Transmission Operation, Diagnosis and Service #17043.45V RPO M3L 6-Speed TREMEC Manual Transmission #14043.17 Passenger Car All-Wheel Drive (Base Curriculum)
Power Steering Power Steering Rack and Pinion ZF Premium Electric with Variable Assist	#13041.12T2 Electric Power Steering Systems #13041.13T1 Rack-Mount Electric Steering #13041.15 GM Steering Systems and Diagnosis (New)
OnStar® OnStar® Generation 9 TechAssist Course	#19040.37 OnStar® Systems and Technology #19040.38T1 OnStar® Systems and Technology
Rear Parking Assist - RPO UD7	#22048.42 GM Safety Systems
Entertainment - Audio Systems Radio-Infotainment System - Uplevel HMI, Enhanced Connectivity - RPO IO5, IO6	#19047.20W2 R2 Entertainment Systems 2 (Including MOST) Network #19047.20W3 Entertainment Systems 3 #19047.22D Infotainment Operation, Diagnosis and Service (VCT)
Tire Pressure Monitor	#13044.20 GM Chassis Control Systems #13044.12T2 Tire Pressure Monitoring Systems Diagnosis
Bluetooth for Phone, Personal Cellphone Connectivity to Vehicle Audio System Bluetooth Technology, Functions and Features Diagnosing and Methods of Radio Programming (USB Programming, Scan Tool Programming)	#19047.20W2 R2 Entertainment Systems 2 (Including MOST) Network
Theft Deterrent System - RPO UTJ	#19047.09W Entry and Security Systems
Parking Brake - Electronically Operated - RPO J77	#15045.14T1 GM Electric Parking Brakes #18044.25 Body Electrical Accessory Systems
Chassis-Continuously Variable Real Time Damping-Magneto Rheological - RPO FE3 Suspension System - Sport	#13044.20 GM Chassis Control Systems #13044.16T1 Continuous Damping Control
Head Up Display (HUD) - RPO UV6	ESS 2 Update
Camera - Rear View - RPO UVC Sensor Indicator-Side Obstacle Detection (Side Blind Zone Alert) - RPO UFT Sensor Indicator-Rear Cross Traffic Alert - RPO UFG Sensor-Collision Avoidance & Mitigation, Vehicle Forward Movement, Brake Prefill & Intelligent Brake Assist – RPO UGN	#22048.42W1 GM Safety Systems 1 #22048.42W2 GM Safety Systems 2 #22048.42W3 GM Safety Systems 3

Dexos1™ Engine Oil Specification — Required Viscosity



3511747



3512027

Only those oils displaying the dexos1™ trademark and a registered trademark logo on the front label of the container meet the demanding performance requirements and stringent quality standards set forth in the dexos1™ specification.

Look on the front label for either of the logos shown above and the 11 digit alphanumeric dexos® license number on the back label to identify an authorized, licensed dexos1™ engine oil. Unless an oil package displays these two markings, the engine oil is not an authentic, licensed dexos® product and is not recommended for use in GM vehicles.

The dexos1™ specification was uniquely designed to complement the exacting requirements of GM's advanced engine technology. The specification has gone through an extensive developmental and testing process. It requires a number of proprietary tests that are not included in current industry standards and sets performance criteria at a level that exceeds many current standards. The result is a high performance fluid providing significant wear protection, improved piston cleanliness, a reduction in volatility and oil consumption, enhanced aeration control for improved fuel efficiency, and better oxidation properties.

Viscosity Grade

Notice: DO NOT use other viscosity grade oils such as SAE 10W-30, 10W-40, or 20W-50.

- SAE 5W-20 is the best viscosity grade for the 2.5L L4 engine. SAE 0W-20 may be used as an alternative. Refer to the latest version of Bulletin Number 13-00-90-001.
- SAE 5W-30 is the best viscosity grade for the 2.0L L4 turbocharged engine and the 3.6L V6 engine.

Refer to this General Motors website for dexos1™ information about the different licensed brands that are currently available: <http://www.gmdexos.com>

CUE System Availability

CUE Equipment Package Content

Model	Standard Infotainment	Available Infotainment
Standard	4.2 inch full-color LCD radio display, AM/FM/XM non-CUE w/ Bose premium 7-speaker audio	CUE w/ Bose premium 7-speaker audio CUE w/ Bose premium 10-speaker surround sound & remote disc player
Luxury	CUE w/ Bose premium 7-speaker audio	Navigation, Bose premium 10-speaker surround sound & remote disc player
Performance	CUE w/ Bose premium 10-speaker surround sound & remote disc player	Navigation
Premium	CUE w/ Navigation, Bose premium 10-speaker surround sound & remote disc player	-

Cleaning High Gloss Surfaces and Vehicle Information Displays and Radio Displays



2873573

Notice: The microfiber cloth is shipped in the bag that contains any loose items that are to be installed when performing the vehicle PDI. Retrieve the microfiber cloth from this bag in the trunk and place it in the Integrated Center Stack (ICS) storage compartment (if equipped) or in the glove box.

The ATS has high gloss surfaces, vehicle information displays and radio displays. Use a microfiber cloth to wipe these types of surfaces. Before wiping the surface with the microfiber cloth, use a soft bristle brush to remove dirt that could scratch the surface. Then use the microfiber cloth by gently rubbing to clean. **DO NOT** use window cleaners or solvents. Periodically hand wash the microfiber cloth separately from other items, using mild soap. **DO NOT** use bleach or fabric softener. Rinse thoroughly and air dry before the next use.

Powertrain / Drivetrain

Engines

The ATS is available with a choice of three powerful and efficient engines coupled with a 6-speed automatic or a 6-speed manual transmission (2.0L Turbo only) and standard rear-wheel drive (RWD) or available all-wheel drive (AWD).

The available engines and specifications are as follows:



2904426

- The Turbocharged (TC) 4-cylinder 2.0L with Dual Overhead Cam (DOHC), Dual Continuous Variable Cam Phasing (DCVCP), Variable Valve Timing (VVT) and Spark Ignition Direct Injection (SIDI) — RPO LTG, produces the following horsepower and torque:
 - 272 hp (203 kW) @ 5,500 RPM
 - 260 lb-ft of torque (353 Nm) @ 1,700-5,500 RPM



2894551

- The 4-cylinder 2.5L with Dual Overhead Cam (DOHC), Dual Continuous Variable Cam Phasing (DCVCP), Variable Valve Timing (VVT) and Spark Ignition Direct Injection (SIDI) — RPO LCV, produces the following horsepower and torque:
 - 202 hp (151 kW) @ 6,300 RPM
 - 191 lb-ft of torque (259 Nm) @ 4,400 RPM



2859946

- The 6-cylinder 3.6L with Dual Overhead Cam (DOHC), Variable Valve Timing (VVT) and Spark Ignition Direct Injection (SIDI) — RPO LFX, produces the following horsepower and torque:
 - 321 hp (239 kW) @ 6,800 RPM
 - 275 lb-ft of torque (373 Nm) @ 4,800 RPM

Transmission

The following transmissions are available:

- Standard on all three engines, is the Hydra-Matic™ 6L45 RPO MYA, 6-speed, electronically controlled, automatic transmission, with automatic overdrive and torque converter clutch.
 - For the 2.0L and the 3.6L, the final drive ratio is 3.27
 - For the 2.5L, the final drive ratio is 3.45
- Available on the 2.0L Turbocharged and 3.6L engines **only**, on the Luxury, Performance and Premium Collection vehicles is the Hydra-Matic™ 6L45 RPO MYA, 6-speed, electronically controlled, automatic all-wheel drive (AWD) transmission. This Active On Demand system continuously monitors multiple inputs and adjusts torque split to optimize both traction and handling. This active system can send up to 100% of the available torque to the front wheels as traction and handling conditions demand.
- Available on the 2.0L Turbocharged engine **only** is the TREMEC TR3160 RPO M3L, 6-speed fully synchronized manual transmission with single overdrive.

Vehicle Enhancements

Frameless Inside Rearview Mirror

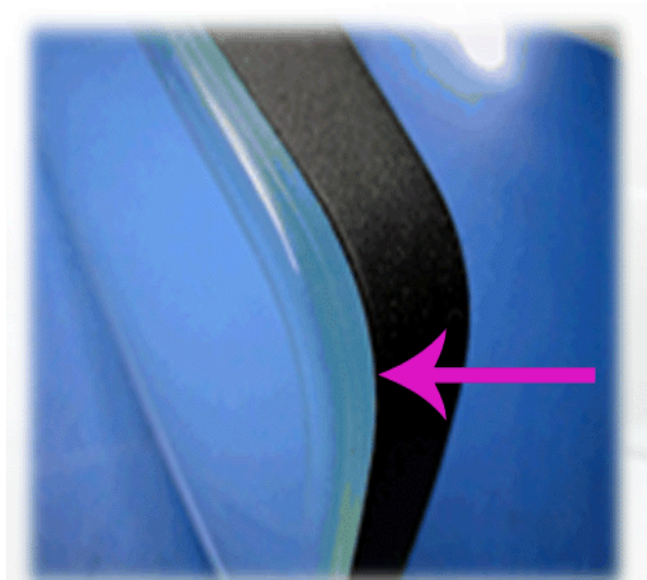

3512871

New for 2014 is a frameless inside rearview mirror.

New Sport Steering Wheel

New for 2014 is a 4 mm thicker-rim sport steering wheel on models equipped with the magnesium steering wheel paddle shift controls.

Conventional Plug Power Receptacle — 110V or 230V

Depending on the global sales market, the Cadillac User Experience (CUE) Navigation Radio — RPO IO6 is equipped with either a 110V (North America) or 230V (Export) conventional plug power receptacle. The 110V or 230V power receptacle, is located in the rear of the front center floor console. Refer to the section in this PI titled: Power Outlet 110 Volt Alternating Current

IntelliBeam System



3530752

If equipped, this system turns the vehicle's high-beam headlamps **ON** and **OFF** according to surrounding traffic conditions. The system turns the high-beam headlamps **ON** when it is dark enough and there is no other traffic present. This indicator light turns **ON** in the instrument cluster when the IntelliBeam system is enabled.

Turning ON and Enabling IntelliBeam System

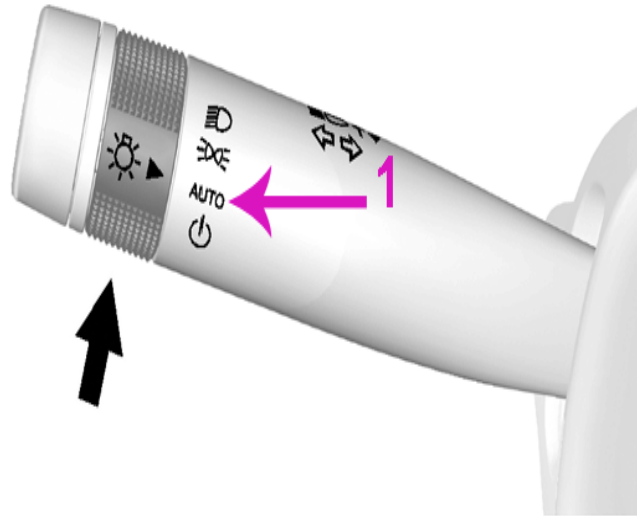

3532907

To enable the automatic high-beam system, place the turn signal lever in the neutral position and turn the exterior lamp control to **AUTO (1)**. The blue high-beam **ON** light appears on the instrument cluster when the high beams are turned **ON**.

The system only activates the high beams when driving over 25 mph (40 km/h). A sensor near the top center of the windshield, automatically controls the system. Keep this area of the windshield clear of debris for best system performance.

The IntelliBeam system has been added to the Driver Awareness Package — RPO Y65 and the Driver Assist Package — RPO Y66

OnStar®

Model Year 2014 OnStar® markets have been expanded to include the United States, Canada, Mexico, China and the Middle East except for Lebanon and Jordan where it is regulatory restricted. OnStar® will be available in Mexico later this year.

One year of OnStar® Directions and Connections service is standard on ATS. OnStar® is the global leading provider of connected safety, security and mobility solutions and advanced information technology.

The OnStar® RemoteLink Mobile App allows smartphone users to control vehicle functions, access vehicle information and send directions directly to the vehicle. An opt-in service called FamilyLink allows subscribers to stay connected to loved ones by checking the location of their vehicle online or by signing up for vehicle location alerts. FamilyLink service is not available in Canada.

More information about OnStar® can be found at this website: www.onstar.com

For OnStar® in Canada, refer to www.onstar.ca

Micro-3™ Terminal Fuses

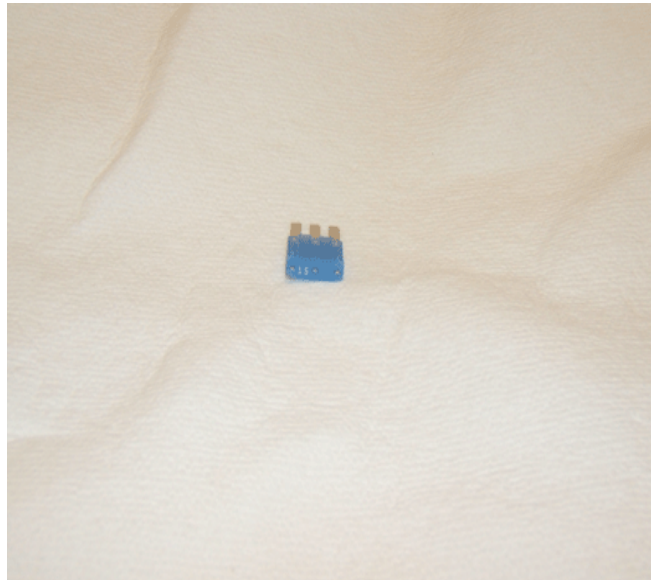

2901532

The MICRO3™ Fuse is the new standard for vehicle circuit protection. The MICRO3™ Fuse has 3 terminals and 2 fuse elements with a common center terminal. Its sub-miniature design meets the need for more circuits to be protected while utilizing less space.

The ATS uses some of the new style Micro-3™ terminal fuses in the underhood electrical center (UEC).

Fuse numbers from the GM Electronic Parts Catalog (EPC):

- GM EPC — P/N 19209797 FUSE, MICRO3 (3 BLADE STYLE) (05.0 AMP) (32V) (TAN)
- GM EPC — P/N 19209798 FUSE, MICRO3 (3 BLADE STYLE) (07.5 AMP) (32V) (BROWN)
- GM EPC — P/N 19209799 FUSE, MICRO3 (3 BLADE STYLE) (10 AMP) (32V) (RED)
- GM EPC — P/N 19209800 FUSE, MICRO3 (3 BLADE STYLE) (15 AMP) (32V) (BLUE)

Trunk Release



2900772



2900782

Notice: When using the touchpad on the rear of the trunk, it may be necessary to press and hold the touchpad for approximately 2–3 seconds in order to open the trunk. This is a normal operating characteristic of the vehicle.

To open the trunk, press the trunk release button on the driver door or the touchpad on the rear of the trunk slightly above the license plate or use the trunk button on the Remote Keyless Entry (RKE) transmitter.

Acoustic Glass

Notice: DO NOT hang key lock boxes on any acoustic glass.

The vehicle is equipped with laminated acoustic glass in the front windshield and the front driver and passenger doors.

Acoustic windshields are the same as a standard windshield, but they have been made with a thin, sound absorbing technology between the glass that reduces the interior noise by 3dB overall, and even more in the frequency where people "hear" the human voice. This technology actually allows automakers to use thinner glass without sacrificing cabin comfort. A lighter windshield also reduces the weight of the vehicle, which improves fuel economy and reduces the CO2 emissions created by the engine.

Reverse Tilt Mirror

If the vehicle is equipped with Reverse Tilt Mirror, when this feature is turned ON, the driver, passenger or both outside rear view mirrors will tilt downward when the vehicle is shifted to **R (Reverse)** to improve visibility of the ground near the rear wheels.

Auto Defog

The climate control system may have a sensor to automatically detect high humidity inside the vehicle. When high humidity is detected, the climate control system may adjust to outside air supply and turn on the air conditioner. If the climate control system does not detect possible window fogging, it returns to normal operation. Auto Defog may be turned off or on in Vehicle Personalization.

Adaptive Forward Lighting

With adaptive forward lighting, the projector headlamps swivel in the direction of the front wheels to maintain forward lighting in concert with vehicle steering.

Heading into a curve or turning a corner, the headlamps swivel up to 15 degrees depending on the curve and vehicle speed. The system works with both low and high beam headlamp settings.

Retained Accessory Power/Accessory Power Outlet Power — Circuit Breaker Replaces Fuse

Accessory Power Outlet (APO) — Circuit Breaker Replaces Fuse

The 2014 ATS will be utilizing a circuit breaker instead of a standard fuse for the accessory power outlets. The purpose of this engineering change is to improve customer experience.

The accessory power outlets can be used to plug in electrical equipment, such as a cell phone or MP3 player. The vehicle has two accessory power outlets:

- Inside the front storage bin below the climate control system.
- On the rear of the center floor console.

The outlets are powered **ON**, when the vehicle is in **ON/RUN/START** or **ACC/ACCESSORY** mode or until a door is opened within 10 minutes of turning **OFF** the vehicle.

Certain electrical accessories **MAY NOT** be compatible with the accessory power outlet and could overload a vehicle circuit breaker or adapter fuse. If overloaded, the circuit breaker will reset after all devices are disconnected or if Retained Accessory Power (RAP) is turned **OFF** and then back **ON**. Wait one minute to allow the circuit breaker to reset before reconnecting devices or turning RAP back **ON**.

Replacing the Factory Power Outlet With a Cigarette Lighter Receptacle — Requires Replacing Circuit Breaker With Minifuse

Caution: Failure to replace the circuit breaker with a minifuse of the correct rating could overheat the cigarette lighter and damage the vehicle. Always check with your dealer before adding electrical equipment.

It is possible to replace the factory power outlet with a cigarette lighter receptacle, if desired. This requires the factory installed circuit breaker to be replaced with a standard minifuse. A minifuse will not reset and will have to be replaced if blown.

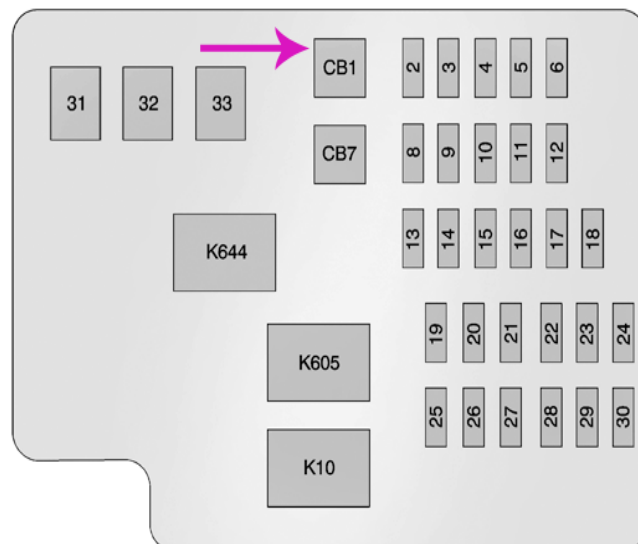

3549619

The circuit breaker CB1, is in the instrument panel fuse block at the end of the driver side of the instrument panel. To access the CB1 circuit breaker, remove the end panel cover.

Power Outlet 110 Volt Alternating Current

If equipped, this power outlet is on the rear of the front center floor console. It can be used to plug in electrical equipment that uses a maximum limit of 150 watts. An indicator light on the outlet turns **ON** to show it is in use. The light turns **ON** when the ignition is in **ON/RUN**, equipment requiring less than 150 watts is plugged into the outlet and no system fault is detected.

The indicator light will **NOT** turn **ON** when the ignition is in **LOCK/OFF** or if the equipment is not fully seated into the outlet.

⇒ If equipment is connected that uses more than 150 watts or a system fault is detected, a protection circuit shuts **OFF** the power supply and the indicator light turns **OFF**.

The power restarts when the device is unplugged for a minimum of 10 seconds and then equipment using 150 watts or less is plugged into the outlet and a system fault is not detected.

The power outlet **IS NOT** designed for the following:

- Equipment with high initial peak wattage such as: a compressor driven refrigerator, electric power tools, hair dryers, etc.
- Equipment requiring an extremely stable power supply such as: a microcomputer-controlled electric blanket, touch sensor lamps, sensitive electronics, etc.

Keyless Ignition with Push Button Engine Start/Stop — Keyless Access — Adaptive Remote Start

Keyless Ignition with Push Button Engine Start/Stop

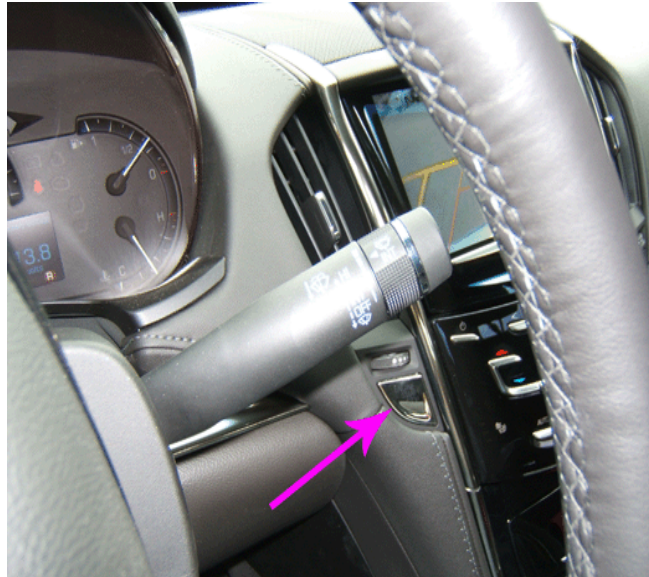

2900453

Keyless Ignition with Push Button Engine Start/Stop is standard on all models. There is a key inside of the remote fob that can be accessed by pushing on the fob release button. This key can unlock the driver door or the passenger door after first removing the cover that conceals the lock cylinder. Refer to: [Unlocking the Door With the Key / Removing the Door Lock Cylinder Cover](#) in this section

Remote Keyless Access

Remote Keyless Access is standard on all models and includes lock, unlock, panic functions and two transmitters.

EZ Key Full Keyless Access

EZ Key Full Keyless Access is standard on the Luxury, Performance and Premium Collections and offers keyless entry to all doors and trunk.

Adaptive Remote Start

Adaptive Remote Start is standard on the Luxury, Performance and Premium Collections and activates the heated seats (if equipped), the climate control system and the rear defroster.

Unlocking the Door With the Key / Removing the Door Lock Cylinder Cover

To unlock the vehicle using the key, follow this procedure. The procedure is the same for the driver door or the front passenger door.

Notice: To remove the door lock cylinder cover, perform Steps 1–5:



2862657

1. Press the fob key release button (1).



2863134

2. Separate the key from the fob by pulling the chrome end (1) away from the fob.

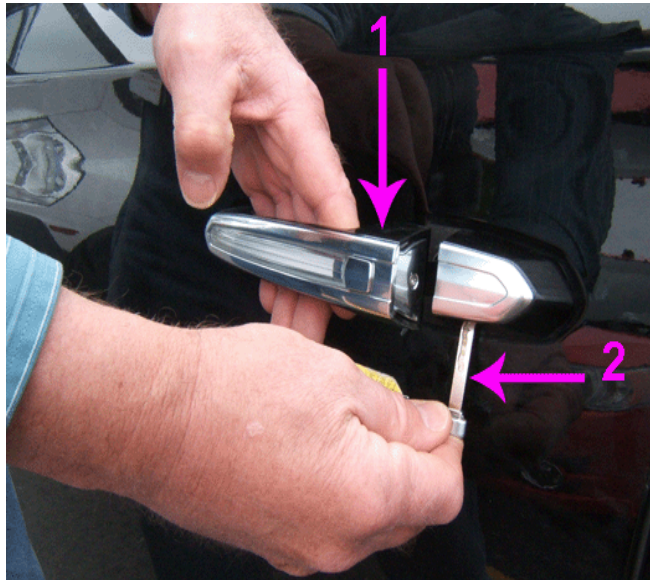

2863207

3. Pull back on the door handle (1) and **HOLD** it in the **OPEN** position. Insert the key (2) into the opening in the bottom of the cover.
4. Gently pry the cover loose with the key.



2863239

5. Remove the cover to gain access to the door lock cylinder.

Notice: To install the door lock cylinder cover, perform Steps 6–10:

6. Pull back on the door handle and **HOLD** it in the **OPEN** position.

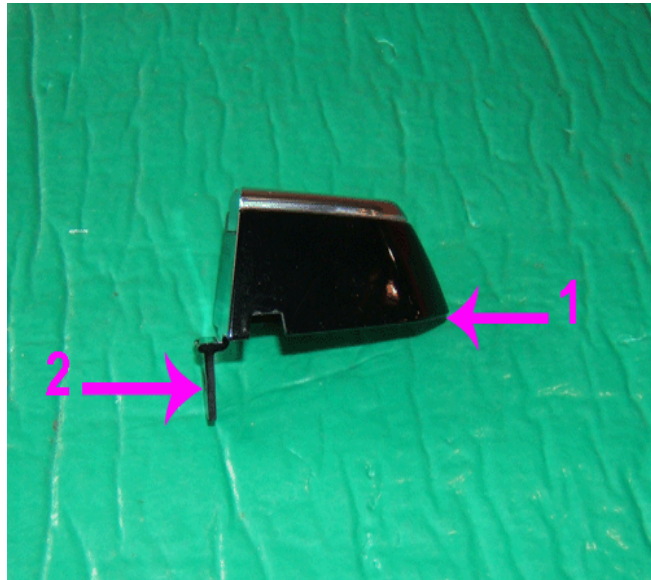

2863249

7. With the door handle in the **OPEN** position, place the cover over the door lock cylinder in order to **SEAT** the **REAR** (1) of the cover first.
8. Gently press the front tab (2) of the cover into the opening.



2863251

9. Verify the cover is secured.
10. Release the door handle.

Unique Vehicle Characteristics — Vacuum Operated Engine Mount System

Vacuum Operated Engine Mounts Description and Operation

An ATS that comes equipped with either the 2.0L RPO LTG or the 2.5L RPO LCV 4-cylinder engine, are equipped with vacuum operated engine mounts. The vacuum operated engine mounts allow the engine to idle at a lower RPM, increasing fuel efficiency and controlling noise, vibrations and harshness (NVH).

The engine mounts are filled with a clear glycol fluid. The fluid is pushed back and forth through different paths in the engine mount by the main rubber element at the top of the engine mount. The fluid flows through the idle and/or bounce tracks/paths which impacts the stiffness of the engine mounts. To control the flow of fluid through the tracks vacuum is turned OFF and ON under two separate diaphragms. The engine mount software is in the fuel pump control module (FPCM). Vehicle operating data is received over the GMLAN. The FPCM determines the appropriate state for the engine mounts based off the vehicle operating conditions.

The system consists of the following components:

- Engine mounts (Qty: 2)
- Vacuum tank assembly
- Valve assemblies (Qty: 2)
- Filter assembly
- An engine mount vacuum hose assembly (includes a check valve)

4-State Vacuum Operated Engine Mount System

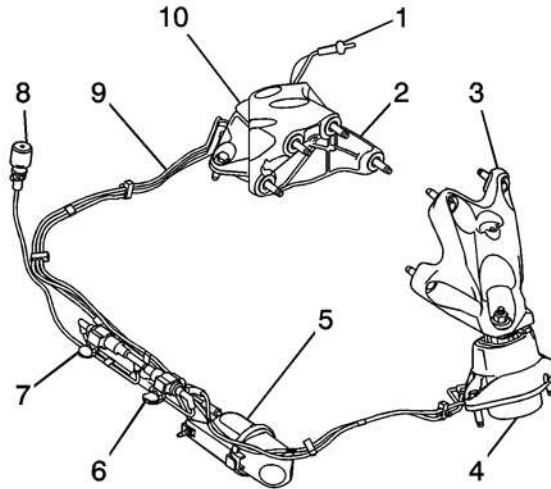

2906353

1. Check Valve
2. RH Engine Mount Bracket
3. LH Engine Mount Bracket
4. LH Engine Mount
5. Vacuum Tank Assembly
6. Idle Valve Assembly
7. Bounce Valve Assembly
8. Filter Assembly
9. Engine Mount Vacuum Hose Assembly
10. RH Engine Mount

Vacuum Operated Engine Mount

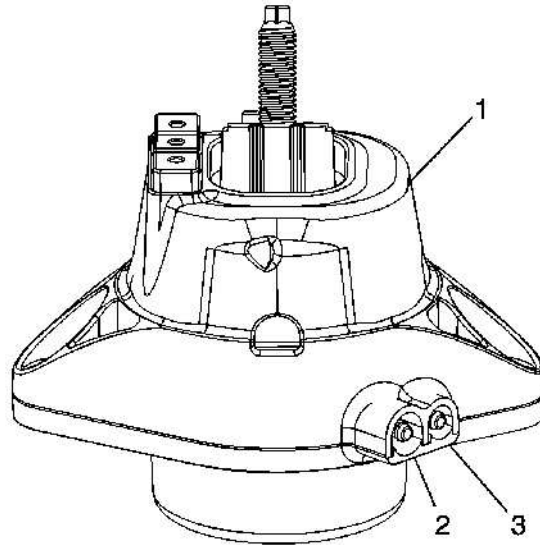

2906360

1. Engine Mount
2. Bounce Port
3. Idle Port

Active Grille Air Shutter

Active Grille Air Shutter Description and Operation

The active grille air shutters are available on the Standard and Luxury models and standard on the Performance and Premium Collections.

The active grille air shutter actuator closes louvers at the front bumper to enhance vehicle aerodynamics in driving situations where cooling and A/C loads are relatively low and high levels of front end airflow are not required.

If high levels of airflow are required the active grille air shutter actuator opens the louvers. The control signal from the fuel pump control module (FPCM), ignition and ground circuits enable the active grille air shutter actuator to operate. If the conditions for opening the louvers are reached the FPCM commands the active grille air shutter actuator to open the louvers.

The actuator is powered by an ignition circuit that is active when the key is in the RUN position. The vehicle may have to be driven for up to 13 minutes at speeds greater than 25 mph (40 kph) before the shutter begins to move. If a low ambient temperature is detected, the shutter will remain in the closed position.

Driver Awareness Package / Driver Assist Package / Safety and Crash Avoidance

The Cadillac ATS introduces a network of cameras, radar and ultrasonic sensors to help the driver avoid crashes by improving their vision and awareness of road hazards, even braking automatically if sensors predict the vehicle is at risk of crashing.

- The Driver Awareness Package is available on the Luxury and included on Performance and Premium Collections and includes the following:
 - Forward Collision Alert
 - Lane Departure Warning (LDW)
 - Safety Alert Seat
 - IntelliBeam System high-beam headlamp control
 - Rear thorax airbags
 - RainSense® windshield wipers
- The Driver Assist Package is available on the on the Performance and Premium Collections and includes all Driver Awareness Package content plus the following:
 - Automatic Collision Preparation
 - Electronic Parking Brake
 - Front and Rear Automatic Braking
 - Full Speed Range Adaptive Cruise Control
 - Full-color head-up display (HUD)

- Side Blind Zone Alert
- Rear Cross Traffic Alert

The control and alert technologies are described in the following:

Safety Alert Seat

The Safety Alert Seat delivers a vibrating pulse, or what is termed a “haptic” alert to the left, right or both sides of the seat cushion. The haptic warning can be de-activated by turning certain related safety systems **OFF**, or be replaced with an audible warning, by using the Vehicle Personalization Settings.

Forward Collision Alert (FCA) System — Setting the Follow Distance Gap

Notice: FCA is a warning system only and does not apply the brakes.

Forward Collision Alert (FCA) uses radar and camera technology to detect and help avoid or reduce the harm caused by a front-end collision. FCA provides a flashing alert on the windshield, and audible beeps or it pulses the Safety Alert Seat when approaching a vehicle directly ahead too quickly, alerting the driver and providing additional time to react. FCA also provides a visual alert if following another vehicle too closely.

FCA detects vehicles within a distance of approximately 197 ft (60 m) and operates at speeds above 25 mph (40 km/h). If the vehicle has Adaptive Cruise Control (ACC), it can detect vehicles to a distance of approximately 360 ft (110 m) and operates at all speeds.



2906796

The driver can set the preferred distance or alerting time using the FCA button on the left hand side of the steering wheel. Press the Follow Distance Gap button (1) to select a distance or time setting for ACC. Select a Gap Setting of Far, Medium, or Near.

Lane Departure Warning



2866824

The Lane Departure Warning (LDW) system is a camera-based lane detection system that uses a camera sensor mounted near the inside rearview mirror to detect the lane markings. LDW warns the driver of unintentional lane departures and **may** provide a warning if the vehicle is crossing a lane without using a turn signal. The LDW system activates at speeds above 35 mph (56 km/h).

When the vehicle crosses a detected lane marking, the LDW indicator will flash and either three beeps will be sounded from the left or right speaker, or three Safety Alert Seat pulses will occur on the left or right side of the seat, depending on the lane departure direction.

Notice: LDW will not warn if the turn signal is ON or if a sharp maneuver is made.

If a turn signal is not used, the LDW indicator will flash and either three beeps will be sounded from the left or right speaker, or three Safety Alert Seat pulses will occur on the left or right side of the seat, depending on the lane departure direction.

Rear Thorax Airbags

Rear Thorax Airbags add more protection for the rear outboard passengers.

Rainsense Automatic Wipers

Rainsense automatic wipers use the forward camera to “read” the moisture on the windshield and automatically adjust wiper intervals accordingly.

Automatic Collision Preparation

Automatic Collision Preparation uses data provided by the front camera, radars and sensors to determine if a collision is imminent. When the vehicle sensors determine a collision is imminent, it uses the Intelligent Braking System to pre-fill and apply braking to lessen the impact severity of the incident or perhaps enable the driver to avoid the incident altogether.

Front and Rear Automatic Braking

Using radar and ultrasonic sensors, this feature can help prevent or mitigate front and rear collisions at low speeds via a progression of alerts that extend to complete braking if necessary. For example, if the vehicle is in stop-and-go traffic, the system will alert if the lead vehicle slows unexpectedly and if needed brake the vehicle to reduce speed to prevent an impact or reduce impact speed.

Full Speed Range Adaptive Cruise Control

The Full Speed Range Adaptive Cruise Control uses information from the car's front radars and other sensors to maintain a selected following distance to the vehicle ahead. The system will even bring the vehicle to a complete stop if needed.

Full-Color Head-Up Display

The Full-Color Head-Up Display allows the driver to configure and display selected information on the windshield in the driver's line of sight.

Side Blind Zone Alert (SBA)

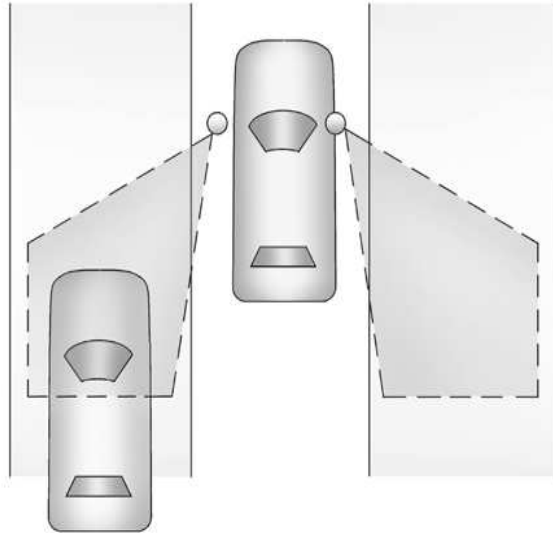

2866901

Using radar sensors in the left and right side corners of the rear bumper, the system looks for vehicles in the blind zone areas and indicates their presence by illuminating symbols in the outside rear view mirrors. The sensors cover a detection zone of approximately one lane over from both sides of the vehicle, approximately 11 ft (3.5 m) and extends rearward approximately 16 ft (5 m). The height of the zone is approximately between 1.5 ft (0.5 m) and 6 ft (2 m) off the ground.

This SBA system does not provide any Haptic feedback.

Rear Cross Traffic Notification



2866857



2866870

Using radar sensors, the driver is alerted of approaching cross traffic when backing out of a parking spot - including angled parking. Using the display in the center stack, with dynamic guidelines laid over the video image, a natural view of objects directly behind the vehicle are provided. Left or right side visual and audible alerts are triggered if moving vehicles are detected.

Rear Vision Camera With Dynamic Guidelines Assists in Parking Maneuvers



2900687



2900694

Using the display in the center stack, with dynamic guidelines laid over the video image, a natural view of objects directly behind the vehicle are provided. The video image can be used to assist in parking maneuvers.

IntelliBeam System

New for the 2014 ATS is the IntelliBeam system. For system information, refer to the sections in this PI titled: **IntelliBeam System** and **Turning ON and Enabling IntelliBeam System**

Airbag System — 8 Airbags for RPO AYG / 10 Airbags for RPO AYF



2868195

Airbags are designed to supplement the protection provided by safety belts.

Notice: The vehicle is equipped with 8 airbags for RPO AYG or 10 airbags for RPO AYF as follows:

- A frontal airbag for the driver.
- A frontal airbag for the front outboard passenger.
- A knee airbag for the driver.
- A knee airbag for the front outboard passenger.
- A seat-mounted side impact airbag for the driver.
- A seat-mounted side impact airbag for the front outboard passenger.

- A roof-rail airbag for the driver and the passenger seated directly behind the driver.
- A roof-rail airbag for the front outboard passenger and the passenger seated directly behind the front outboard passenger.

Notice: For RPO AYF add these two airbags:

- Seat-mounted side impact airbags for the second row outboard passengers.

Head-Up Display (HUD)

Available on the Performance and standard on the Premium Collection is the full-color, configurable Head Up Display (HUD). HUD is any transparent display that presents data without requiring the driver to look away from their usual viewpoints.

Some of the important information concerning the operation of the vehicle is projected onto the windshield. The images are projected through the HUD lens on the instrument panel.

The HUD may display different alerts and information for vehicles equipped with these features:

- Traction Control System (TCS)
- StabiliTrak System
- Collision Alert
- Gap Adjust
- Upcoming Maneuver from OnBoard Navigation
- Upcoming Maneuver from OnStar®
- Incoming Call

When the HUD is **ON**, the speedometer reading is continually displayed, except when an imminent navigation maneuver is being shown. The current audio, phone, or navigation alert temporarily displays if their status changes. This occurs if the steering wheel controls are used to adjust a setting or acknowledge an alert.

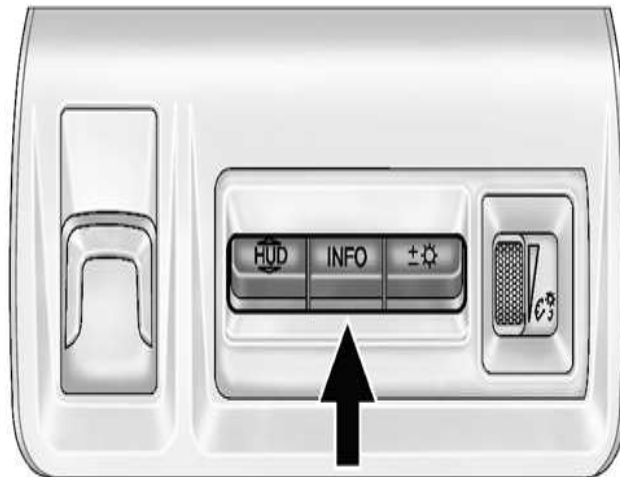

2868363

The HUD Control is to the left of the steering wheel. To adjust the HUD image, select the data display and change the brightness perform the following:

1. Adjust the driver seat.
2. Start the engine.
3. Press the left side **HUD** button **down** or **lift up** to center the HUD image. The HUD image can only be adjusted up and down, not side to side.
4. Press the middle **INFO** button to select the data display view. Release when the desired data display is shown on the HUD. If vehicle messages are displayed, pressing the DIC select button may clear the message.
5. To change the brightness of the display use the right side button with the +, - and lamp icons. **Lift up** and **hold** to brighten the display. Press **down** and **hold** to dim the display. Hold down to turn the display **OFF**.

Steering Wheel Controls - Cruise Control / Heated Steering Wheel

Left Side Steering Wheel Controls - Cruise Control and Heated Steering Wheel

Using cruise control, a speed of about 25 mph (40 km/h) or more can be maintained without keeping your foot on the accelerator. If the brakes are applied, the cruise control disengages. If the StabiliTrak[®] system begins to limit wheel spin while using cruise control, the cruise control automatically disengages.

The following describes the functions of the Cruise Control buttons and the Heated Steering Wheel button (if equipped):

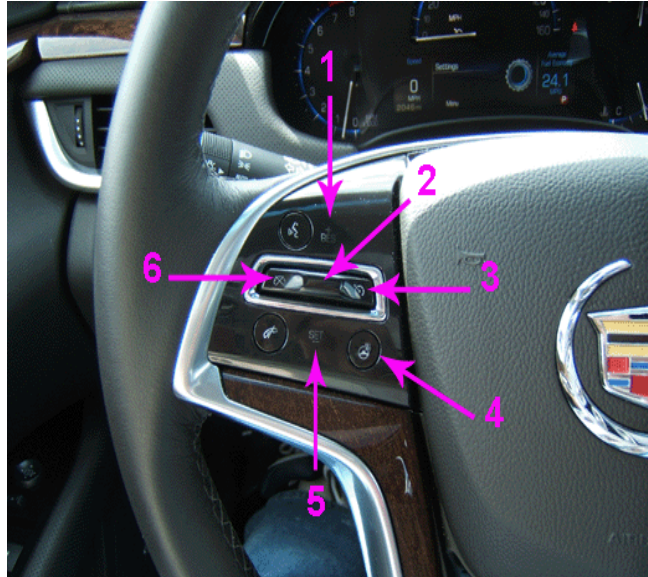

2869270

- **ON/OFF:** Press the **ON/OFF (3)** button to turn the system **ON** and **OFF**. An indicator lamp will illuminate on the instrument cluster when the cruise control is turned **ON**.
- **+RES (Resume/Accelerate):** Press the **Five-Way Control Bar (2) UP** briefly towards the **+RES (1)** icon, to resume to a previously set speed or to increase vehicle speed if the cruise control is already activated.
 - To increase vehicle speed by 1 mph (1 km/h), press the **Five-Way Control Bar (2) UP** towards the **+RES (1)** icon, to the **first detent**.
 - To increase vehicle speed by 5 mph (5 km/h), press the **Five-Way Control Bar (2) UP** towards the **+RES (1)** icon, to the **second detent**.
- **SET (Set/Coast):** Press the **Five-Way Control Bar (2) DOWN** briefly towards the **SET- (5)** icon, to set the speed and turn the cruise control **ON**, or to decrease the speed if the cruise control is already activated.
 - To decrease vehicle speed by 1 mph (1 km/h), press the **Five-Way Control Bar (2) DOWN** towards the **SET- (5)** icon, to the **first detent**.
 - To decrease vehicle speed by 5 mph (5 km/h), press the **Five-Way Control Bar (2) DOWN** towards the **SET- (5)** icon, to the **second detent** .
Brake intervention may occur to slow the vehicle to the new set decreased vehicle speed.
- *** (Cancel):** Press the *** CANCEL (6)** button to disengage the cruise control without erasing the set speed from memory.
 - ⇒ If the cruise control button is **ON** when not in use, it could get pressed and go into cruise control when not desired. Keep the cruise control button **OFF** when cruise is not being used.
- Press the **Heated Steering Wheel (4)** button to turn the heated steering wheel **ON/OFF**. A light next to the button illuminates when the feature is turned **ON**.

Left Side Steering Wheel Controls - Phone and Audio Controls

The following describes the functions of the Phone and Audio buttons:

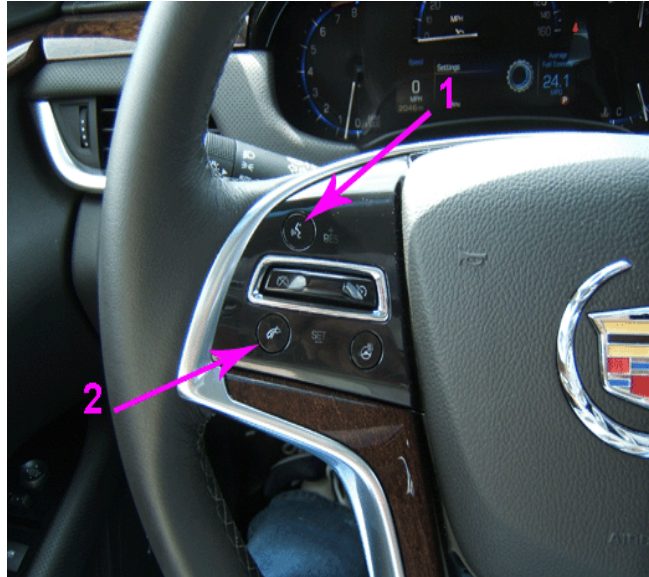

2869282

- **Push to Talk:** For vehicles with OnStar® or a Bluetooth® system, press the **Push to Talk (1)** button, to talk or use a verbal voice command.
- **End Call:** Press the **End Call (2)** button to decline an incoming call, or to end a current call.
- **End Call:** Press the **End Call (2)** button to mute or unmute the infotainment system.

Steering Wheel Controls / Infotainment System

Right Side Steering Wheel Controls - Infotainment System

The following describes the functions of the Infotainment System buttons:

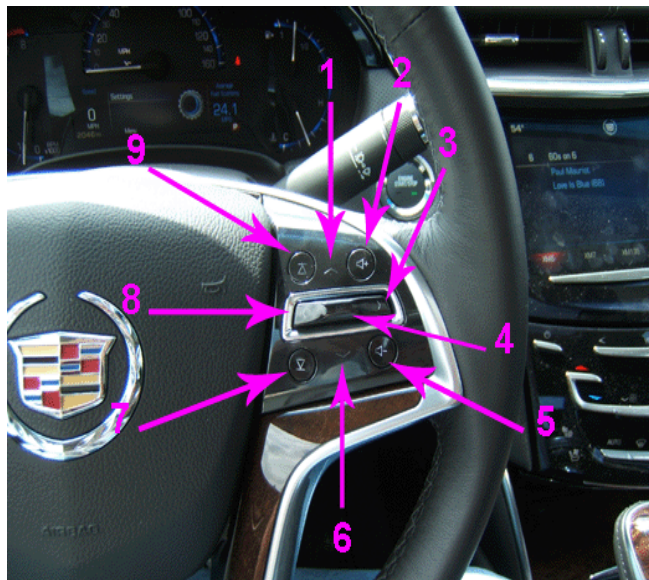

2869349

- **^ or V (Next or Previous):** Press the **Five-Way Control Bar (4) UP** towards (1) to go to the next selection.
- **^ or V (Next or Previous):** Press the **Five-Way Control Bar (4) DOWN** towards (6) to go to the previous selection.
- **< or > (Previous or Next):** Changes cluster vehicle information, when selected under **Vehicle Settings in Information**.
 - Press **> (3)** for the right side cluster information.
 - Press **< (8)** for the left side cluster information.
 - Press **< (8)** when **BACK** is displayed in the cluster to **EXIT** an information selection.

- **SEL (Select):** Press **SEL (4)** on the center of the **Five-Way Control Bar (4)** to select a highlighted menu option.

Notice: These are not **SEEK** buttons. **Active Favorites must be stored in order for this function to operate.**

- **Next or Previous Favorite:** To go to the next favorite radio station or CD/MP3 track press the **UP (9)** symbol.

Notice: These are not **SEEK** buttons. **Active Favorites must be stored in order for this function to operate.**

- **Next or Previous Favorite:** To go to the previous favorite radio station or CD/MP3 track press the **DOWN (7)** symbol.
- **+ or - (Volume):** Press the **+ (2)** speaker symbol to increase volume.
- **+ or - (Volume):** Press the **- (5)** speaker symbol to decrease volume.

Safety Locks

When activated, the rear door safety locks prevent passengers from opening the rear doors from inside the vehicle. The rear door power windows are also disabled.



2869404

Press the safety locks (1) button to activate the safety locks on the rear doors. The LED indicator light in the switch (2) will illuminate when activated.

Press the safety locks (1) button again to deactivate the safety locks. The LED indicator light will turn OFF.

⇒ If the LED indicator light is flashing as a result of the rear door handle being partially engaged during deactivation, press the safety locks (1) button 2X. to deactivate the flashing LED indicator light and the rear door lockout.

Bluetooth® System

The in-vehicle Bluetooth® system is standard on all models. The Bluetooth® system allows users with a Bluetooth® enabled cellphone to make and receive hands-free calls using the vehicle's audio system, microphone and controls. The Bluetooth® enabled cellphone **MUST** be paired with the vehicle Bluetooth® system **BEFORE** it can be used in the vehicle.

Not all Bluetooth® cellphones will work with the vehicle's Bluetooth® system or support all functions. Bluetooth® enabled cellphones will be tested for vehicle compatibility and a Feature Compatibility list will be published on the Bluetooth® website.

Notice: To Canadian Dealers, the following is a United States website that is presented in English only. Canadian carriers are not listed directly, but when identified, the phone model functions are similar.

For more information go to: <http://www.onstar.com/web/bluetooth>

Notice: The 2014 ATS selection will be added soon. Select 2014, when it becomes available.

On the Bluetooth® Home page, Go to: Pair Your Phone > Select Vehicle > Select Make > Select Cadillac > Select Year > Select 2013 > Select Model > Select ATS > Select Radio (vehicle's radio system) Select Submit > Select Compatible Devices > Select Your Device

Power Window Operation

Express Window Operation

Power windows with the express-down and/or express-up feature allow the window to be lowered or raised without holding the switch. When operating the driver's power window switch all windows will operate with the express-down and express-up feature.

Rear Window / Defogger Grid - Antenna Grid / Multi-Band Antenna

Defogger Grid

When the rear window defogger switch is pressed and the engine is running, the rear defog control system will remain active for 10 minutes. After the initial cycle has lapsed, pressing the switch again will continue rear window defogger operation, but the cycle will only last 5 minutes. The rear defog control system will function continuously if the vehicle speed is greater than 45 mph (70 km/h).

AM-FM Antenna Grid

The AM-FM antenna is integrated with the rear window defogger in the rear window.

Multi-Band Antenna

The roof antenna is for OnStar®, SiriusXM® Satellite Radio, and the Global Positioning System (GPS). Keep clear of obstructions for clear reception. If the vehicle has a sunroof, and it is open, the reception can also be affected.

Towing A Disabled Vehicle

Notice: Please share this information with your towing providers.

Towing the Vehicle / Flatbed Car Carrier

Notice: Incorrectly towing a disabled vehicle may cause damage. The damage would not be covered by the vehicle warranty.

Have the vehicle towed on a **flatbed car carrier**. A wheel lift tow truck could damage the vehicle.

Using the Tow Eye

Notice: A tow eye may be used to move a disabled vehicle if the proper equipment is used. Use caution and low speeds to prevent damage to the vehicle. There is one threaded socket on the front and one threaded socket on the rear of the vehicle.

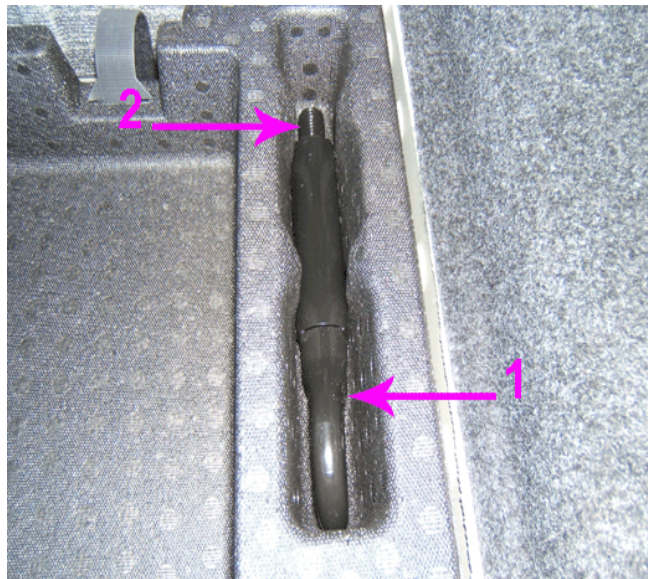

2901439

1. Retrieve the tow eye (1) from its storage compartment in the trunk.



2901455

2. Use a plastic trim tool or an equivalent to carefully remove the tow eye socket cover from the front or rear fascia of the vehicle.

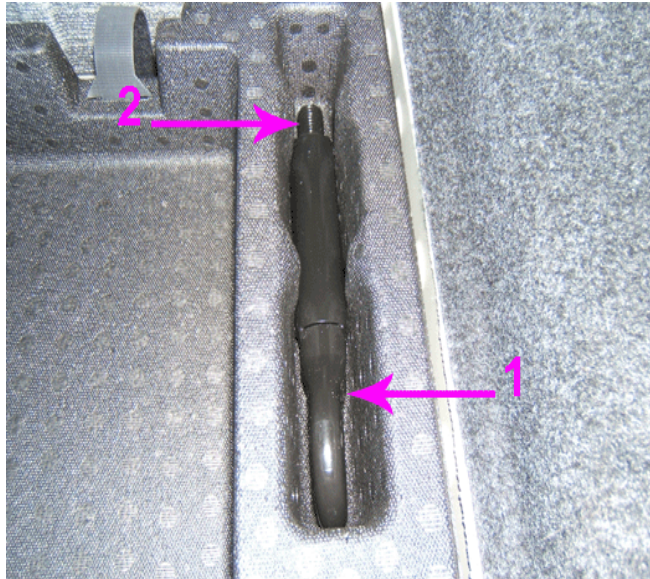

2901439



2901467

3. Install the threaded end (2) of the tow eye into the threaded socket (1) by turning it clockwise until it stops.
4. When the tow eye is removed, reinstall the cover with the notch in the original position.
5. Return the tow eye to the storage compartment in the trunk.

Special Tools

Tool #	Description
GE-50078	Electronic Refrigerant Leak Detector
DT-51075	Puller Legs, Manual Transmission - Tremec 6-Speed
DT-51076	Installer, Bearing and Gear, Manual Transmission - Tremec 6-Speed
DT-51077	Shift Rail Seal Installer, Manual Transmission - Tremec 6-Speed

Quality Pre-Delivery Inspection (PDI)

Please be sure to review the Pre-Delivery Inspection (PDI) and Completely Satisfied Delivery System (CSDS) forms published for this vehicle. There are several Special Inspection Items highlighted for this vehicle. Additionally the CSDS form has important customer education items that have been identified during the Captured Test Fleet process.

- United States Dealers should report any product issues via a Field Product Report (FPR). Refer to the latest version of Corporate Bulletin Number 02-00-89-002 Information for Dealers on How to Submit a Field Product Report.
- Canadian Dealers should report any product issues via a Product Information Report (PIR). Refer to the latest version of Corporate Bulletin Number 10-00-89-006 Information for Dealers on How to Submit a Product Information Report.

Bose®, **Studio Surround®** Sound and **Personal®** Speakers are Registered Trademarks of the Bose Corporation

dexos 1™ is a Trademark of General Motors LLC

OnStar® is a Registered Trademark of OnStar LLC

OnStar® RemoteLink™ is a Trademark of OnStar LLC

Bluetooth® is a Registered Trademark of Bluetooth SIG, Inc.

Hydra-Matic™ is a Trademark of General Motors LLC

MIDTRONICS® is a registered trademark of MIDTRONICS, INC.

Pandora® is a Registered Trademark of Pandora Media, Inc.

"XM RADIO® is a Registered Trademark of Sirius XM Radio Inc.."

StabiliTrak® is a Registered Trademark of General Motors LLC

iPad® is a Registered Trademark of Apple, Inc.

iPod® is a Registered Trademark of Apple, Inc.