



Service Bulletin

File in Section: -

Bulletin No.: PI0983B

Date: November, 2013

PRELIMINARY INFORMATION

Subject: Information on Accessory Bed Liner Installation for Pre-Drilled Bed Liners and for Vehicles Equipped With Upper Tie-Downs

Models: 2014 Chevrolet Silverado 1500
2014 GMC Sierra 1500

This PI has been revised to add information to Recommendation/Instructions 1.
Please discard PI0983A.

Condition/Concern

During installation of the bed liner, technicians/installers may find that some vehicles have one of the following conditions:

- The accessory bed liner may have pre-drilled holes to accommodate tie-downs installed in the front and rear side locations of the pickup bed. The installer may have difficulty installing the 3½" plugs provided for the holes where upper tie downs are not installed. Refer to Recommendation/Instructions #1.
- The vehicle may have upper tie-downs installed in the (front and rear) side locations of the pickup bed, however there are no access holes in the accessory bed liner that match these tie-down locations. Refer to Recommendation/Instructions #2 (Note: in this scenario, the upper tie downs will not be reconfigurable or removable).

Recommendation/Instructions 1 – Bed Liners with Pre-Drilled 3½" Upper Tie-Down Access Holes

Affected Part Numbers: 23423550, 23423551 and 23423552.

Note: An improved fitting plug is being developed and information on it's availability will follow in the near future. A video showing how to install the current plug can be viewed by accessing web link <http://vimeo.com/77788076> and entering password: bedlinerplug.

Tip: For easier installation of the bed liner plugs, install the plugs in the unused upper tie down locations PRIOR to installing the liner to the vehicle.

If the plugs are difficult to install, follow the steps below:



3630452

Important: DO NOT make the notch any larger than the recommended dimension below, and DO NOT add multiple notches. Doing either of these will cause the plug to easily pop out after installation.

1. Cut a relief "V" notch into the plug as shown in the graphic above. The widest distance of the "V" (1), should be approximately 12-15 mm (0.472–0.590 in).
2. Position the plug to the hole in the bed liner with the "V" notch at the bottom, and begin seating by pushing the top of plug into the hole.



3630454

3. Continue pushing/seating the plug around both sides of the perimeter, from top to bottom.



3630455

4. Push the bottom “V” notch area into place.



3630456

5. Lastly, push firmly in the center of the plug and ensure the plug is fully seated in the hole, as shown in the graphic above.
6. Repeat the above installation steps, as necessary, for all unused upper tie down locations.

Recommendation/Instructions 2 – Bed Liners without Upper Tie-Down Access Holes

Affected Part Numbers: 23123699, 22879299, 23123698 and 22879300.

Important: In this scenario, the upper tie downs will not be reconfigurable or removable.

For installing bed liners missing the upper access holes, on vehicles with upper tie-downs, locate and drill four 5 cm (2.0 in) holes in the accessory bed liner to accommodate the upper tie-down locations. The following graphics contain dimensions for locating the center of these hole positions. Holes should be marked and drilled from the outside of the bed liner.

Left Side: Front (1) and Rear (2) Locations

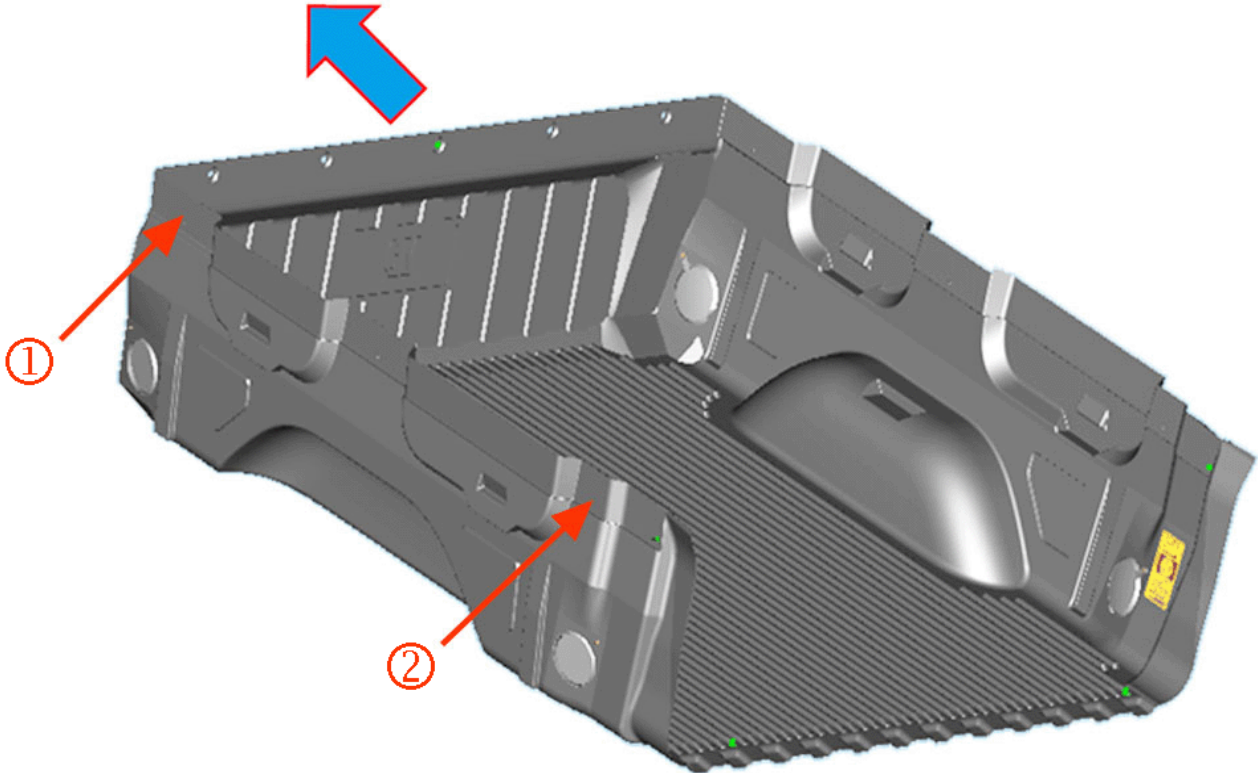

Left Front Location Dimensions

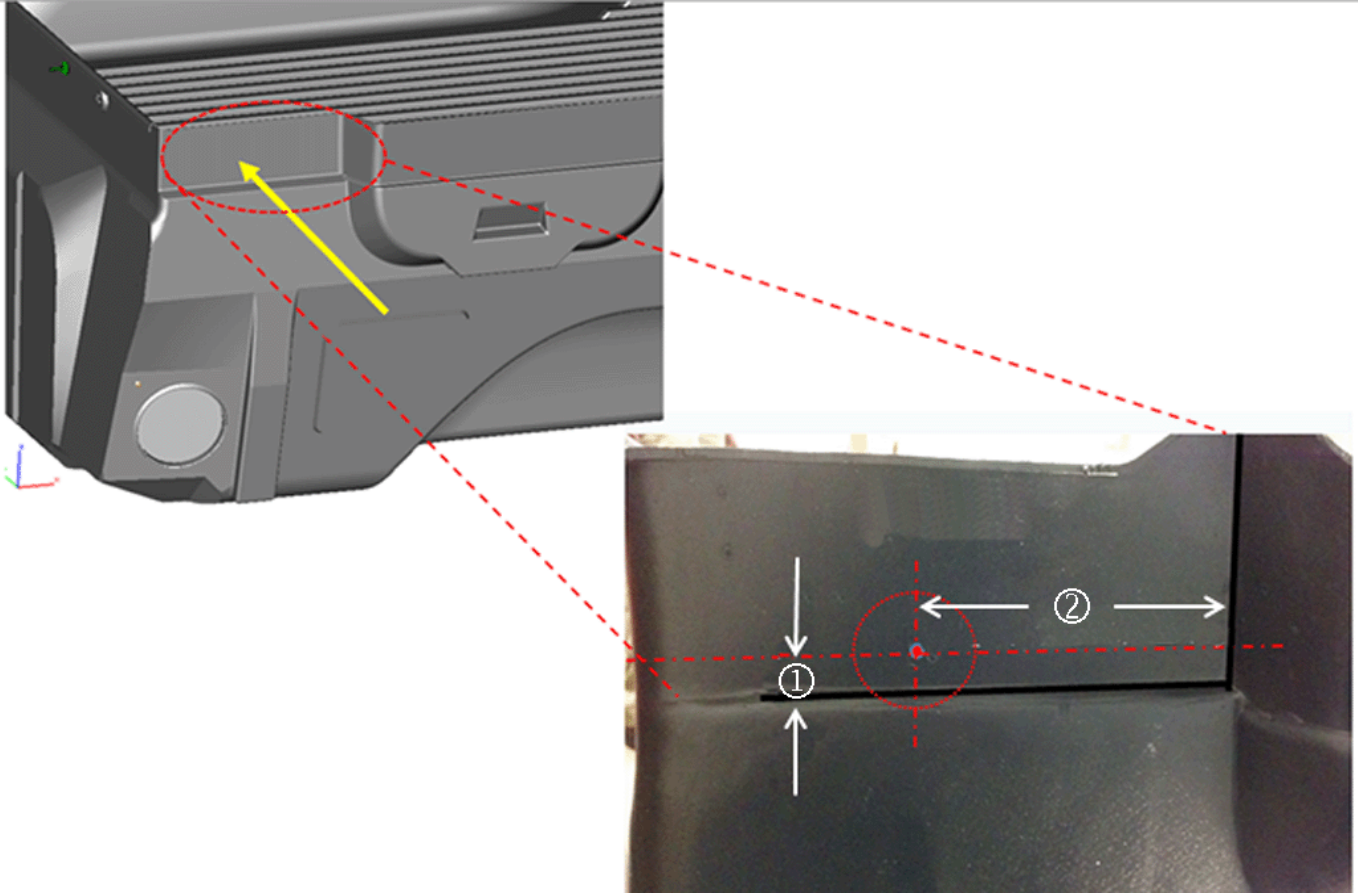

3462932

- (1) = 11 mm (0.43 in)
- (2) = 120 mm (4.75 in)

Left Rear Location Dimensions

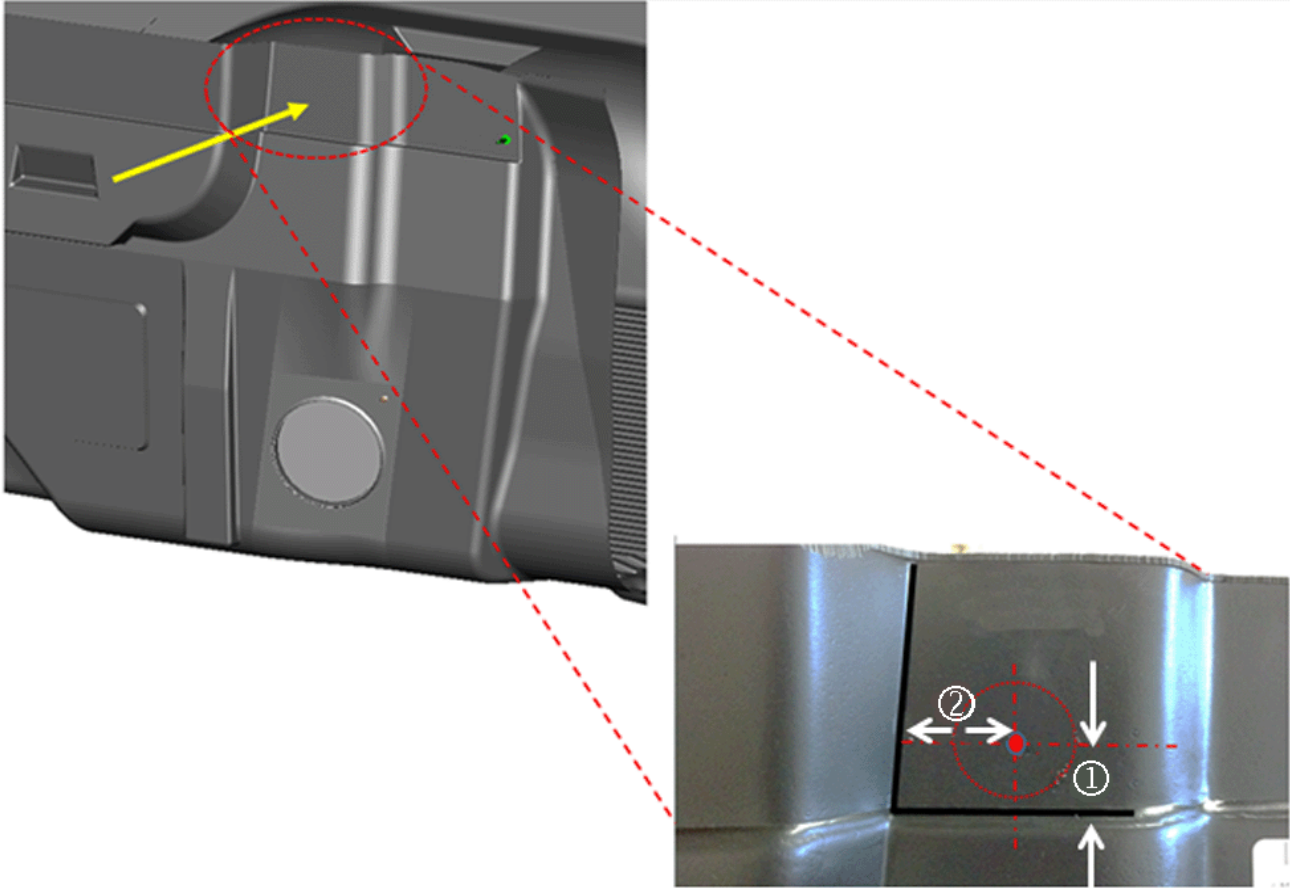

3468346

Important: To better control the accuracy of the rear locations, it is critical to mark the location of the horizontal line first. Measure the distance upward (1) in several areas, and using a marker or tape, position a line at that level. Then, along that line, mark the intersecting point for the second measurement (2).

(1) = 21 mm (0.825 in)

(2) = 38 mm (1.5 in)

Right Side: Front (3) and Rear (4) Locations

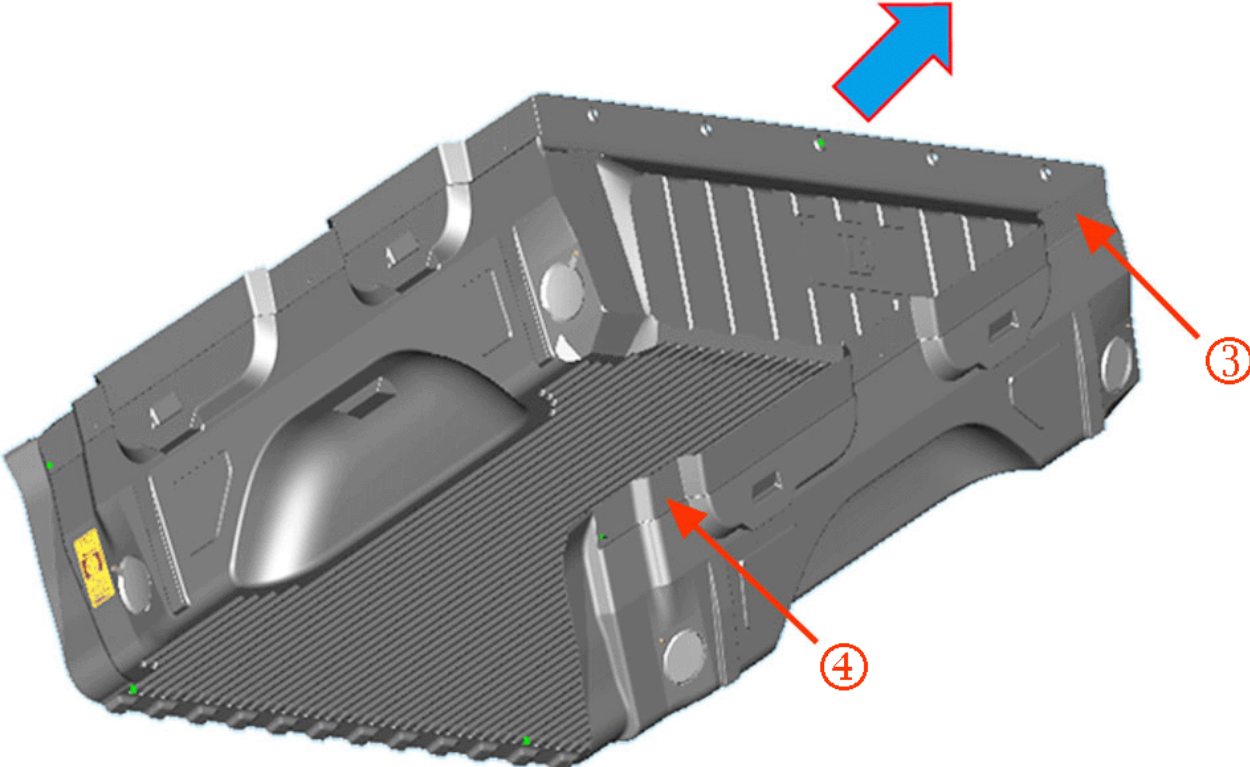

Right Front Location Dimensions

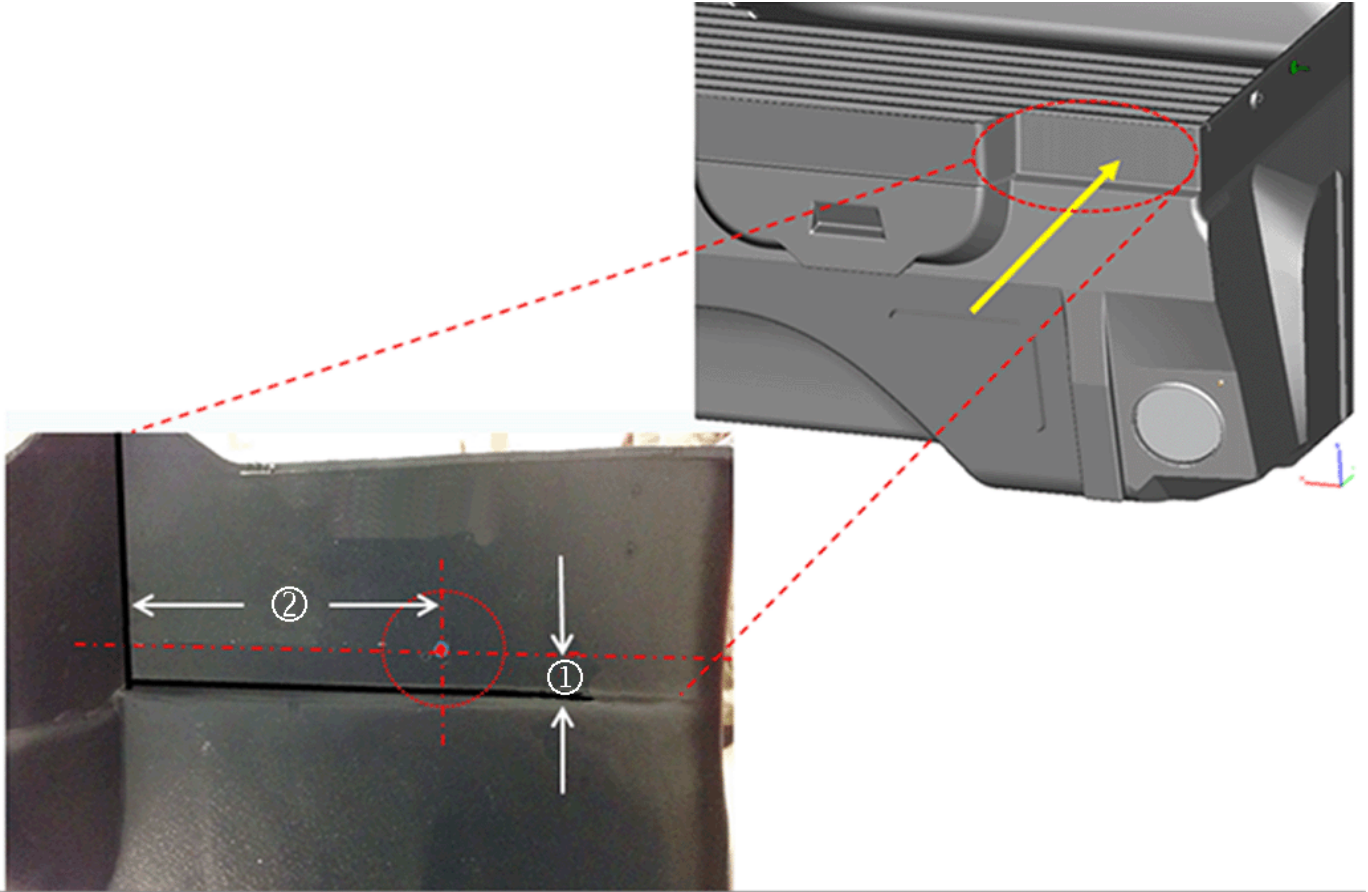

- (1) = 11 mm (0.43 in)
- (2) = 120 mm (4.75 in)

Right Rear Location Dimensions

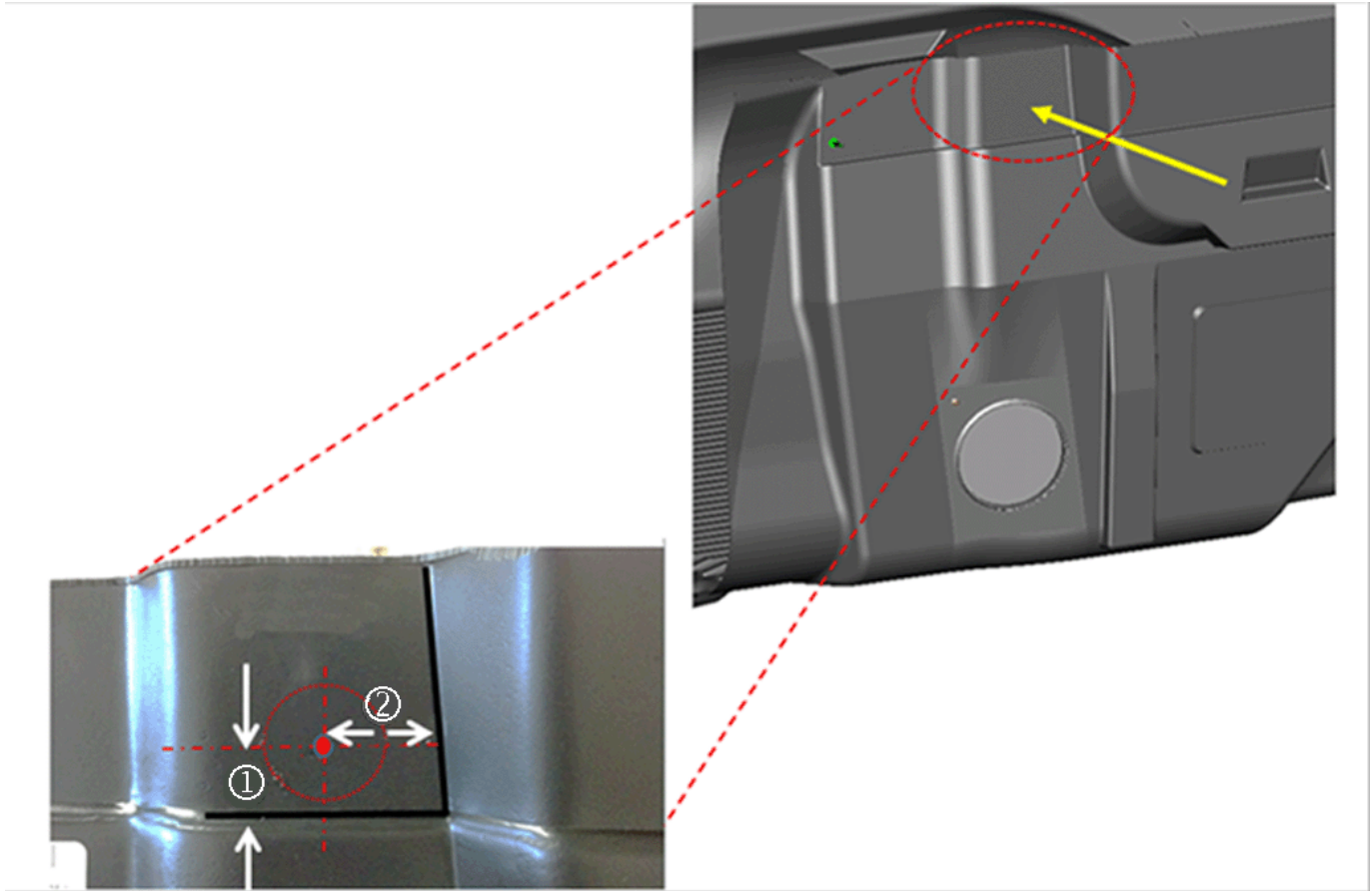

3468348

Important: To better control the accuracy of the rear locations, it is critical to mark the location of the horizontal line first. Measure the distance upward (1) in several areas, and using a marker or tape, position a line at that level. Then, along that line, mark the intersecting point for the second measurement (2).

(1) = 21 mm (0.825 in)

(2) = 38 mm (1.5 in)

Warranty Information

For vehicles repaired under warranty, use:

Labor Operation	Description	Labor Time
0580008*	Add Upper Tie Down Access Holes to Bed Liner	0.5 hr

*This is a unique labor operation for bulletin use only. It will not be published in the Labor Time Guide.