



Service Bulletin

File in Section: -

Bulletin No.: PI0811A

Date: November, 2013

PRELIMINARY INFORMATION

Subject: Front Seat Cushion Outer Trim Panel Broken

Models: 2011-2013 Chevrolet Caprice PPV
2008-2009 Pontiac G8

This PI has been revised to add the 2013 model year to Chevrolet PPV and add the Pontiac G8 Model. Please discard PI0811.

Condition/Concern

Some customers may comment that the outer side trim panel retaining brackets on the driver or passenger front seat may break, resulting in loose or dislodged trim.

The cause of this condition may be that excessive pressure is applied to the seat trim, usually when entering or exiting the vehicle, which results in the trim panel breaking.

Recommendation/Instructions

For vehicles displaying this condition, replace the front seat cushion outer trim panel and add service kit reinforcement brackets following the procedure below:

1. Obtain a new front seat cushion outer trim panel. Refer to the GM electronic parts catalog (EPC).

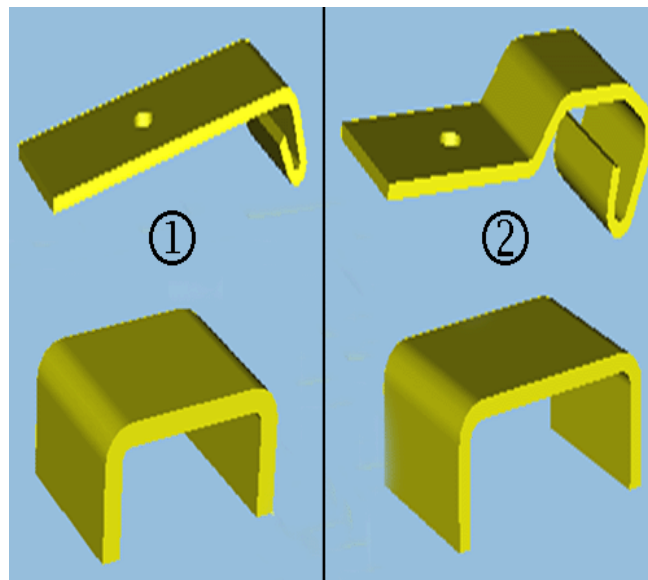

2904406

2. Obtain a Front Seat Side Cover Service Repair Kit (P/N referenced in the parts information below). The kit consists of a front hook bracket and C bracket (1), a rear hook bracket and C bracket (2) and two self tapping screws.
3. Disable the supplemental inflatable restraint (SIR) system. Refer to SIR Disabling and Enabling in SI.
4. Slide the affected front seat fully forward and raise it fully upwards to allow easier access.

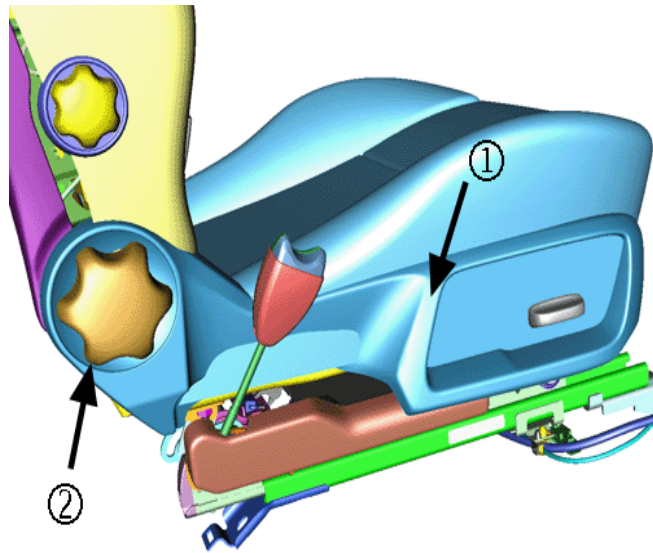

2904408

5. Remove the seat cushion outer trim panel (1) following the steps below:
 - 5.1. Remove the recliner knob (2) , if equipped, by gently prying it off with a suitable tool.
 - 5.2. Detach the rear of the outer trim panel from the hinge assembly.



2904409

- 5.3. Reaching under the trim panel, pull the metal retaining tab outboard to release the trim panel from the seat frame.

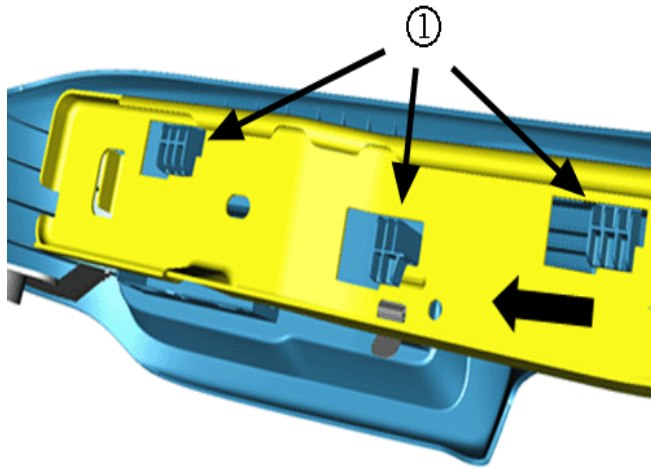

2904411

- 5.4. While holding the release tab, slide the trim panel forward to release the three J shaped retainers (1) that hold the trim to the seat frame.
- 5.5. Disconnect the seat switch electrical connector from the trim panel.

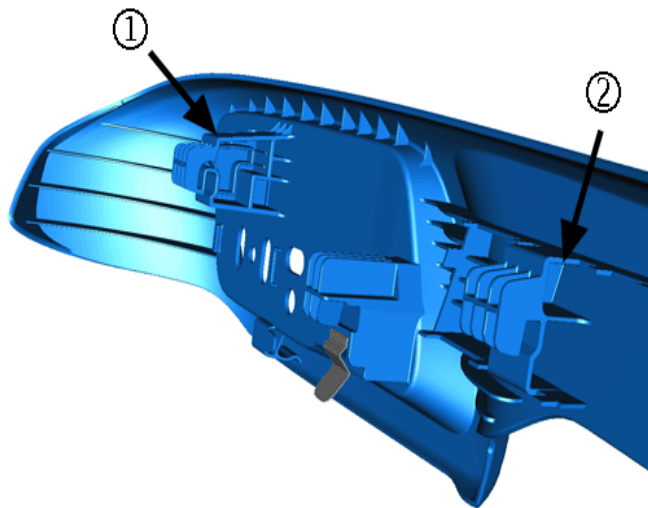

2904412

Note: The smaller C bracket goes on the front mounting point (1), the larger one on the rear (2).



2904413

6. Install the two C shaped brackets from the Seat Side Cover Service Repair Kit into the mounting bosses of the new trim panel as shown above.

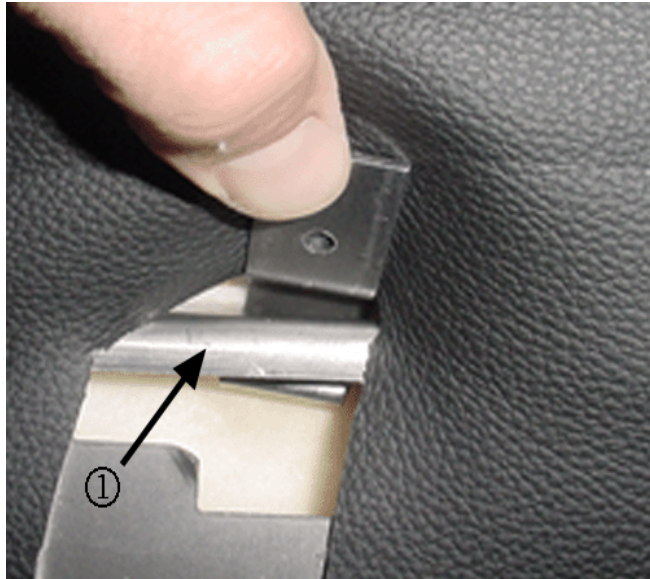

2904414

7. Fit the new hook brackets, from the repair kit, to the seat frame by pushing them over the seat frame rail (1) then working them up and down until the angle is right to allow the bracket to clip over the rail.



2904415

8. Slide the hook brackets rearwards into position as shown above.
9. Install the new seat cushion outer trim panel to the seat, but do not install the recliner knob, if equipped.



2904416

10. Push the seat cushion inwards to expose the new brackets that were just installed. Ensure the hook brackets align with the plastic bosses on the trim panel that have the C brackets lodged inside.



2904418

11. With the brackets aligned, mark the new screw hole locations through each hook bracket hole onto the plastic seat trim underneath.

Note: You can use the supplied self tapping Tek Screw to drill the hole, or use a suitable sized drill bit.

12. Remove the trim panel, and with the trim on a bench or suitable surface, drill a hole through the plastic trim and through the C bracket underneath in the location you have just marked.
13. Reconnect the seat switch electrical connector and reinstall the trim panel to the seat.



2904419

14. Protect the seat with a clean rag and install the supplied screws into the brackets that you have just installed as shown above.
15. Reinstall the recliner knob, if equipped.
16. Enable the supplemental inflatable restraint (SIR) system. Refer to SIR Disabling and Enabling in SI.

Parts Information

Part Number	Description	Qty
92252188	Front Seat Side Cover - Service Repair Kit	1 each seat
Refer to EPC	Panel, Frt Seat Cush Otr Fin	1 each seat

Warranty Information

For vehicles repaired under warranty, use:

Labor Operation	Description	Labor Time
7080058*	Replace Front Seat Cushion Outer Trim Panel - Add Brackets	0.3 hr
*This is a unique labor operation for bulletin use only. It will not be published in the Labor Time Guide.		