



Service Bulletin

File in Section: -

Bulletin No.: PI0625A

Date: May, 2013

PRELIMINARY INFORMATION

Subject: Hydraulic Pump Leaking Fluid in Area of Rear Seat, Floor or Trunk, Convertible Top Inoperative or Noise

Models: 2011-2014 Camaro Convertible

This PI is being revised to add the 2013 and 2014 model years. Please discard PI0625.

Condition/Concern

Some customers may comment on seeing hydraulic fluid leaking onto or under the rear seat, on the rear floor and/or into the trunk area of the vehicle. Upon attempting to operate the convertible top, they may also comment that the hydraulic pump is making a noise or does not operate.

The cause of this condition may be that the fluid reservoir on the pump was either improperly installed at the supplier or knocked out of position during installation to the vehicle and is leaking oil.

Recommendation/Instructions

When the above condition is found, DO NOT replace the pump assembly. Verify the leak condition and reposition the hydraulic pump reservoir by completing the following steps:

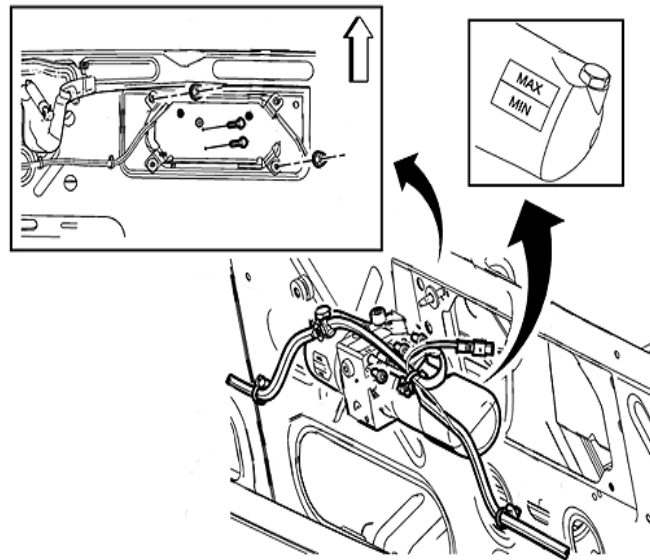

2741237

1. Remove and reposition the folding top pump assembly without disconnecting the hydraulic lines. Refer to Folding Top Pump with Motor Replacement in SI.

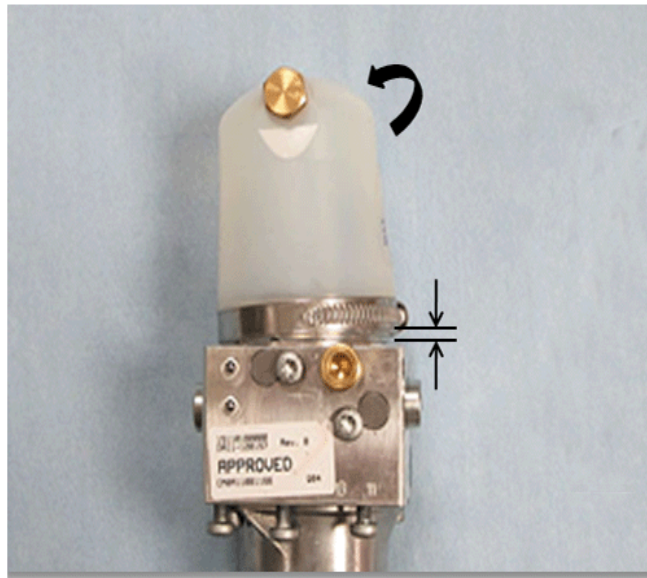

2741238

2. Inspect the fluid reservoir for correct installation/position on the pump assembly. The graphic above shows an example of the reservoir tipped and not properly seated, which exposes a gap where fluid can leak.

Important: When fully seating the reservoir, make sure the original position of the reservoir and the retaining clamp is maintained and that neither is rotated in relation to the pump.

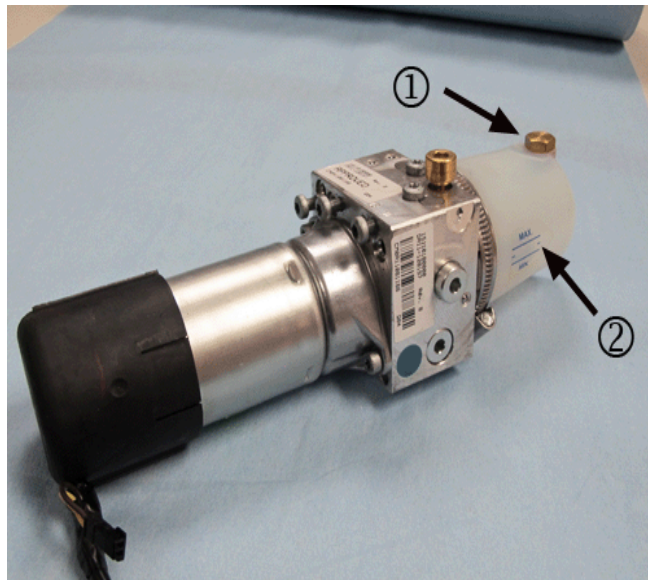

2744333

- For proper fluid level readings, ensure the reservoir fill plug (1) is on the top of the reservoir and the fluid level indicator label (2) is centered on the side of the pump.

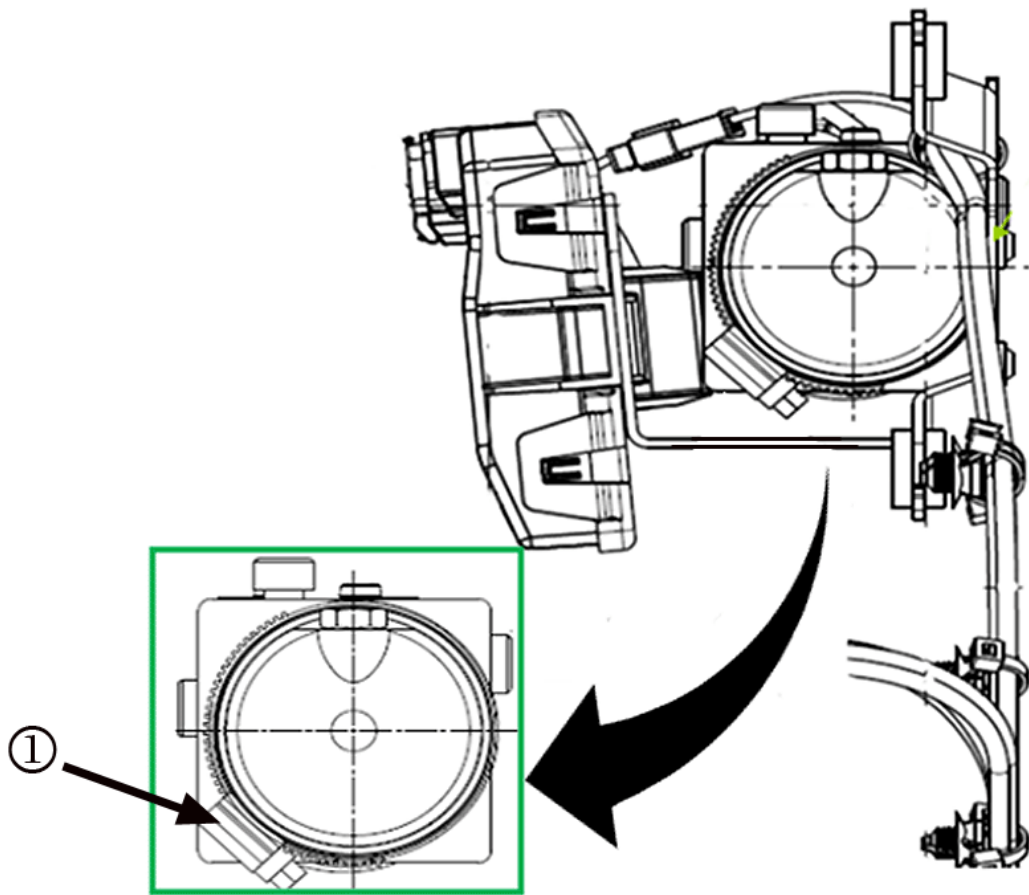

2744330

- For proper mounting of the pump to its mounting bracket, ensure the orientation of the screw housing (1) on the retaining clamp is as shown in the side view/in-vehicle position graphic above.



2741245

3. Loosen the retaining clamp screw and fully seat the reservoir to the pump. Re-tighten the clamp screw.

Tighten

Tighten the screw to 4 N•m (35 lb in).

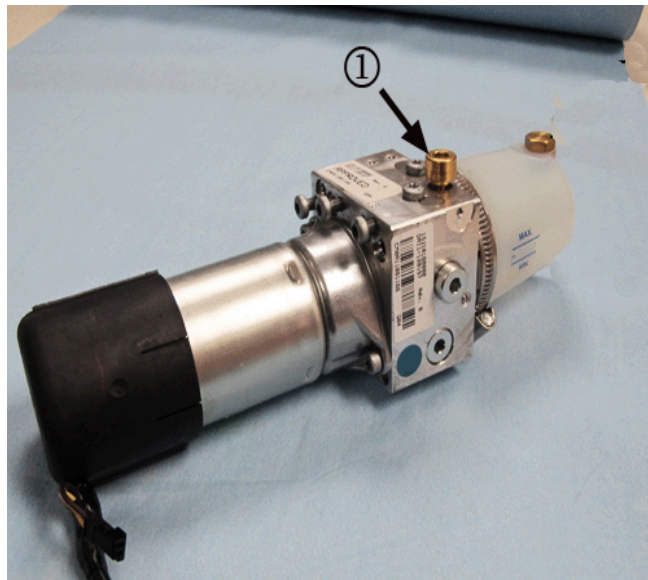

2744331

Important: When checking for fluid leaks, pay close attention to the manual release valve (1). A maximum of one and a half revolutions is recommended when opening this release valve. If for any reason the valve was turned out more than one and a half revolutions, the potential for damaging the valve seal could exist. This valve seal is NOT serviceable, so once the release valve is fully closed, if any fluid leak is evident at the valve location, the folding top pump assembly would have to be replaced.

Note: Recommended torque specifications for the reservoir fill plug is 2 N•m (18 lb in) and for the manual release valve is 4 N•m (35 lb in).

4. Fill the reservoir and inspect for any leaks. Refer to Folding Top Fluid Addition in SI.
5. Reinstall the pump assembly and verify proper operation of the convertible top. Refer to Folding Top Pump with Motor Replacement in SI.

Warranty Information

For vehicles repaired under warranty, use:

Labor Operation	Description	Labor Time
6011220	Folding Top Pump with Motor Replacement	Use Published Labor Operation Time