



Program Bulletin



CUSTOMER SATISFACTION PROGRAM

SUBJECT: Windshield Water Leak

MODELS: 2012 Buick Verano

.....
THIS PROGRAM IS IN EFFECT UNTIL MAY 31, 2015.
.....

CONDITION

The windshield on **certain** 2012 model year Buick Verano vehicles may not be completely sealed to the body at the lower left side of the windshield. Water could leak into the vehicle at this point and drip onto the body harness connector, causing corrosion on the terminals or shorting between terminals. Depending on the terminal(s) involved, it could cause one or more of the following conditions: automatic OnStar® emergency calls, flashing of the park brake light, rough engine operation, improper air conditioning system operation, illumination of the Service Engine Soon light, and other malfunctions.

CORRECTION

Dealers are to perform a water test to detect a water leak. If a leak is found, dealers are to reseal the area and perform another water test. If leaking is still present, the windshield is to be reinstalled. If evidence of a leak is found, the connectors are to be inspected to determine if any terminals are corroded. Corroded terminals are to be replaced.

VEHICLES INVOLVED

All involved vehicles are identified by Vehicle Identification Number on the Investigate Vehicle History screen in GM Global Warranty Management system. Dealership service personnel should always check this site to confirm vehicle involvement prior to beginning any required inspections and/or repairs. It is important to routinely use this tool to verify eligibility because not all similar vehicles may be involved regardless of description or option content.

For dealers with involved vehicles, a listing with involved vehicles containing the complete vehicle identification number, customer name, and address information has been prepared and will be provided to dealers through the GM GlobalConnect Recall Reports. Dealers will not have a report available if they have no involved vehicles currently assigned.

The listing may contain customer names and addresses obtained from Motor Vehicle Registration Records. The use of such motor vehicle registration data for any purpose other than follow-up necessary to complete this program is a violation of law in several states/provinces/countries. Accordingly, you are urged to limit the use of this report to the follow-up necessary to complete this program.

PART INFORMATION

Parts required to complete this program are to be obtained from General Motors Customer Care and Aftersales (GMCC&A). Please refer to your "involved vehicles listing" before ordering parts. Normal orders should be placed on a DRO = Daily Replenishment Order. In an emergency situation, parts should be ordered on a CSO = Customer Special Order.

| Part Number | Description | Quantity/Vehicle |
|----------------|--|-------------------------|
| 13257301 | CLIP, BODY WRG HARN | 1 (if req'd) |
| 11611080 | CLIP, W/S SI R/MLDG | As Needed (if req'd) |
| Refer to SI | Connector Terminal | If Req'd |
| Obtain Locally | Urethane Adhesive Kit (must meet GM specification GM 3651G) | If Req'd |

SERVICE PROCEDURE

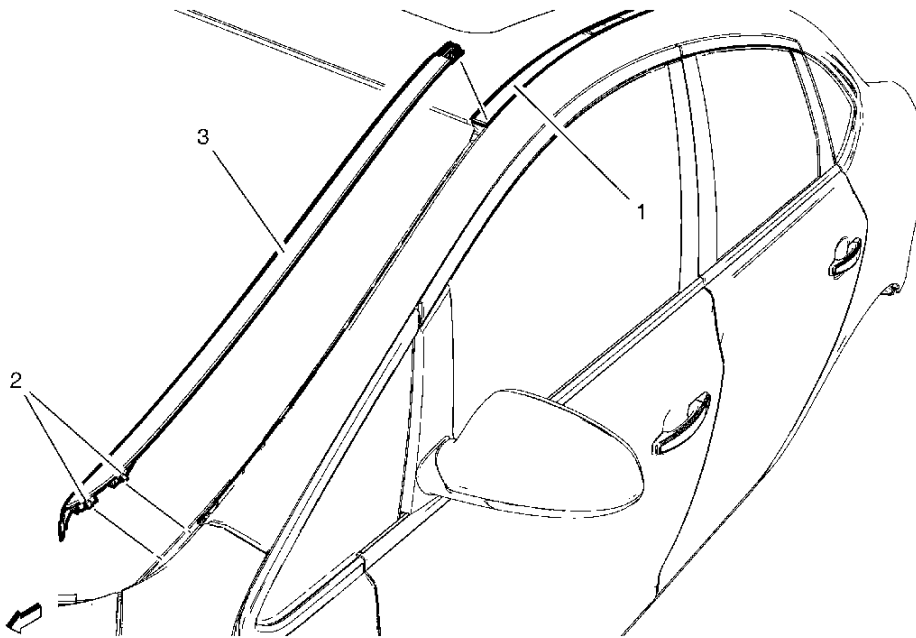

2811163

1. Using a body trim tool or equivalent, remove the windshield side reveal molding. Refer to *Windshield Side Reveal Molding Replacement* in SI.

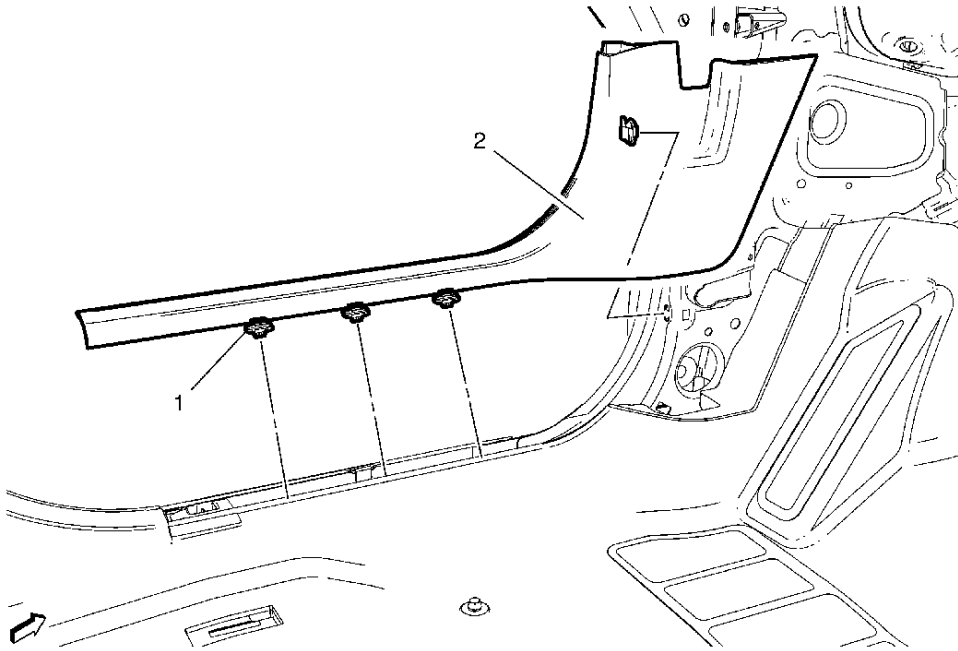

2631308

2. Open the driver side door and remove the front side door sill trim plate. Refer to *Front Side Door Sill Trim Plate Replacement* in SI.

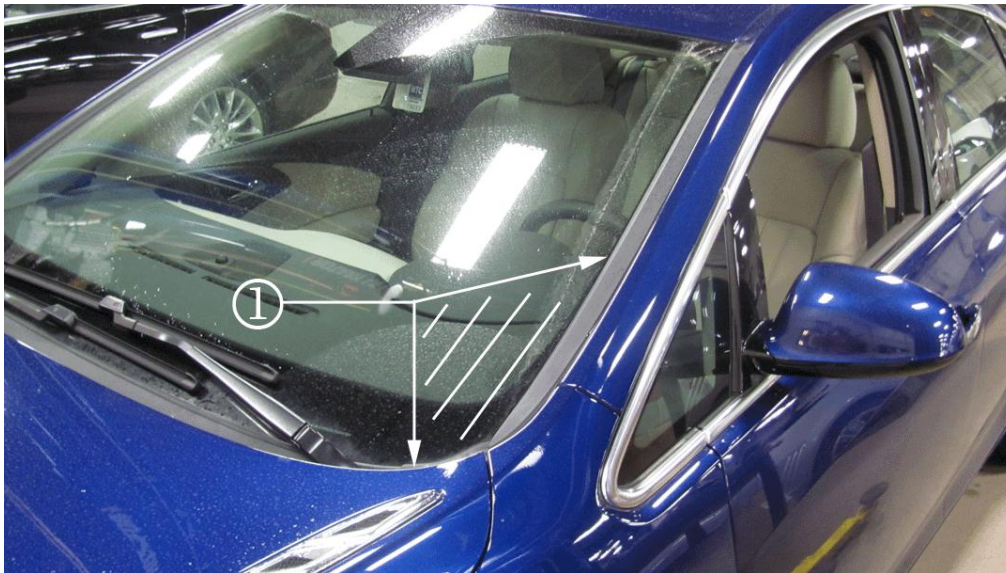

3350863

Remove the windshield side reveal molding before performing the water test.

3. Perform a windshield water leak test on the driver side of the windshield in the A-pillar area of the windshield using a water hose without the nozzle attached. Refer to photograph to view where to apply water (1).

Note: Inspect the area below the driver side of the instrument panel near the A-pillar for evidence of a water leak during the windshield water leak test. Carefully inspect the area around the instrument panel harness to body harness connector for evidence of a water leak. Visually inspect the instrument panel harness to body harness connector to ensure that it does not show signs of corrosion. Ensure the instrument panel harness to body harness connector does not get wet during the water leak test.

- 3.1 Use an assistant to determine if a water leak is present. The assistant should sit inside the vehicle to inspect the vehicle for a water leak.

- 3.2 Perform the water test for 2-3 minutes to ensure the driver side A-pillar area of the windshield is exposed to enough water to determine if a leak is present.
 - If a water leak is not present, proceed to step 7.
 - If a water leak is present, proceed to step 4.
4. Clean the edge of the windshield in the area of the leak with a 50/50 mixture of isopropyl alcohol and water and lint-free cloth. Ensure the windshield and the metal around the edge of the windshield are clean BEFORE applying the urethane adhesive.

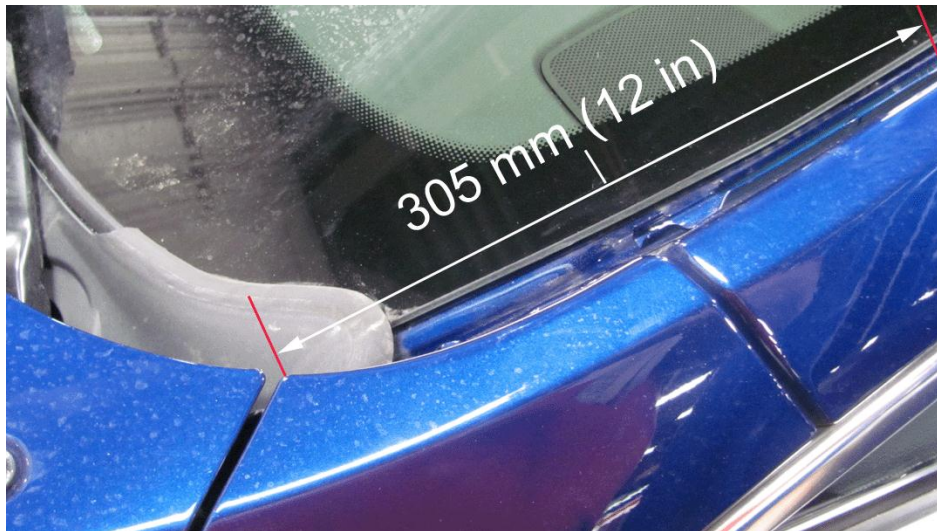

3350866

5. Using a urethane adhesive kit that meets GM specification GM 3651G, apply a bead of urethane to the 305 mm (12 in) leak point area of the windshield.
 - 5.1 Use a plastic paddle to apply extra urethane adhesive at the leak point.
 - 5.2 Retest the windshield for a water leak.
 - If a water leak is NOT present, proceed to step 6.
 - If a water leak is present, refer to *Windshield Replacement* in SI. Proceed to step 6, after the windshield has been replaced.

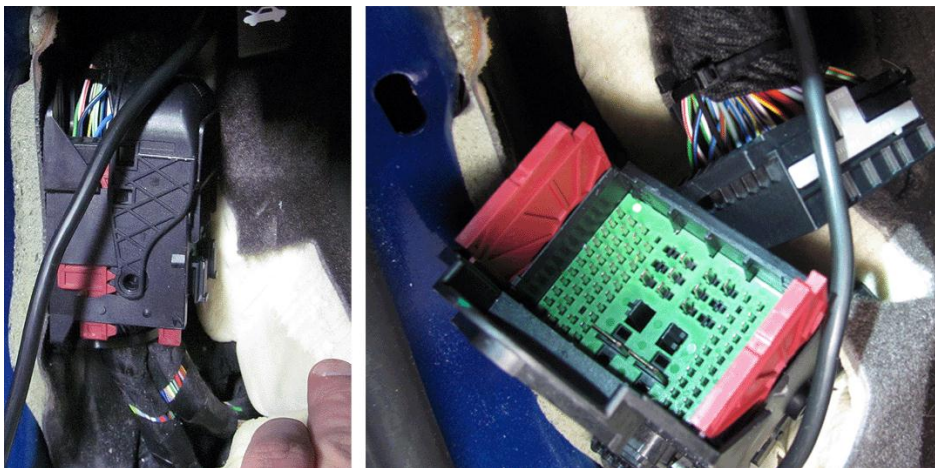

3350869

6. Carefully inspect the condition of the instrument panel harness to body harness connector.
 - 6.1 Disconnect the negative battery cable. Refer to *Battery Negative Cable Disconnection and Connection* in SI.
 - 6.2 Disconnect the connector and inspect the connector for corrosion.

- 6.3 Inspect the connector for terminal damage.
- 6.4 Inspect the condition of the connector body.
 - If the connectors and terminals are NOT damaged and do NOT show signs of corrosion, connect and secure the connectors. Proceed to step 7.
 - If the connectors and/or terminals are damaged or show signs of corrosion, replace the damaged or corroded terminals. Refer to *Terminal Removal, Repairing Connector Terminals* and *X 200 Instrument Panel Harness to Body Harness* in SI. Proceed to step 7 after repairing the terminals.

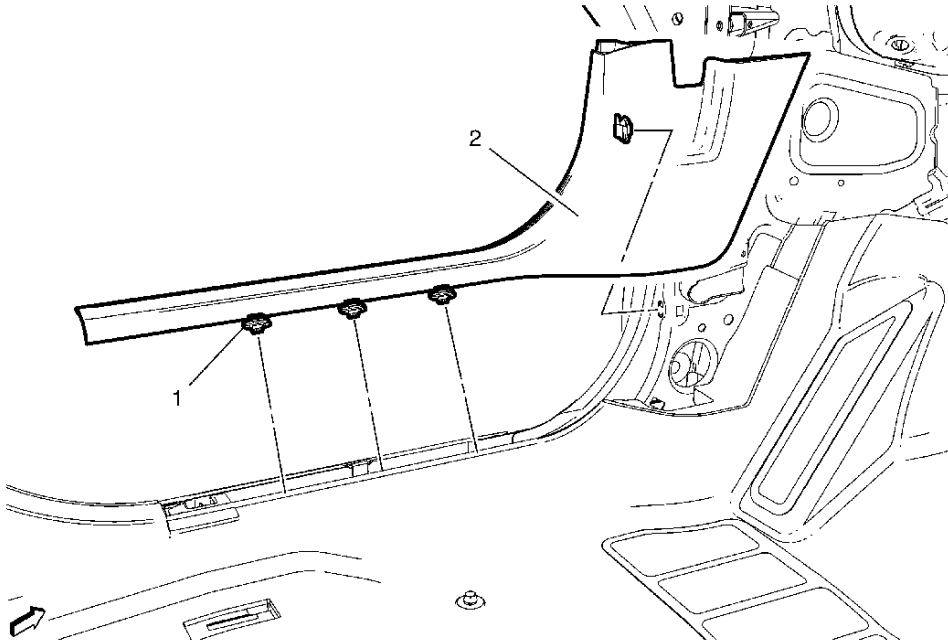

2631308

7. Install the front side door sill trim plate. Refer to *Front Side Door Sill Trim Plate Replacement* in SI.

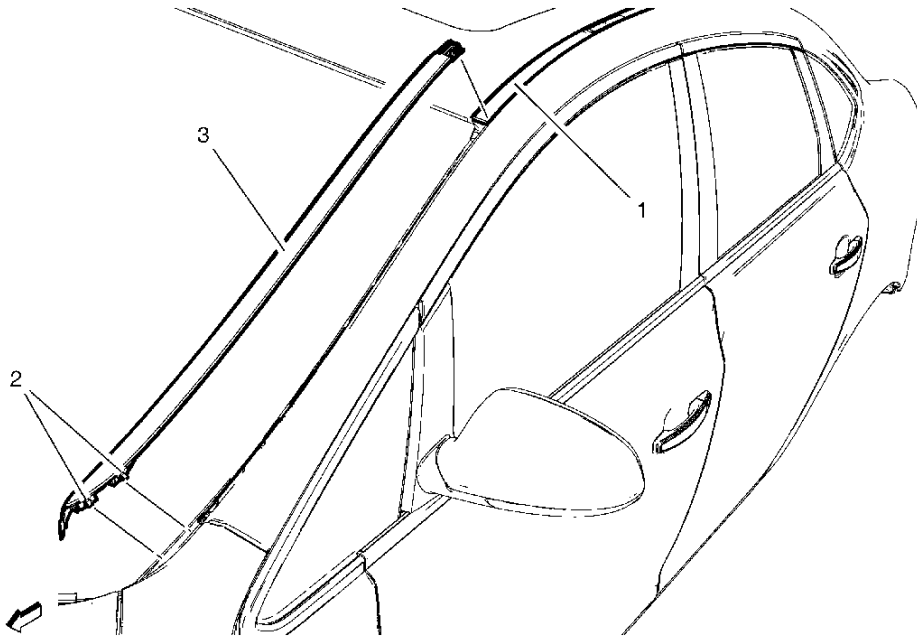

2811163

8. Install the windshield side reveal molding. Refer to *Windshield Side Reveal Molding Replacement* in SI.
9. Connect the negative battery cable. Refer to *Battery Negative Cable Disconnection and Connection* in SI.

COURTESY TRANSPORTATION – For US and Canada

The General Motors Courtesy Transportation program is intended to minimize customer inconvenience when a vehicle requires a repair that is covered by the New Vehicle Limited Warranties. The availability of courtesy transportation to customers whose vehicles are within the warranty coverage period and involved in a product program is very important in maintaining customer satisfaction. Dealers are to ensure that these customers understand that shuttle service or some other form of courtesy transportation is available and will be provided at no charge. Dealers should refer to the General Motors Service Policies and Procedures Manual for Courtesy Transportation guidelines.

WARRANTY TRANSACTION INFORMATION

Submit a transaction using the table below. All transactions should be submitted as a ZFAT transaction type, unless noted otherwise.

| Labor Code | Description | Labor Time | Net Item |
|-------------------|---|-------------------|-----------------|
| V2787 | Water Test Windshield – No Further Action Req'd | 0.8 | N/A |
| V2788 | Water Test Windshield & Apply Urethane Adhesive | 1.3 | * |
| | Add: Reinstall Windshield | 1.2 | |
| | Add: Connector Terminal Repair | 0.3-3.0 | ** |

* The amount identified in “Net Item” should represent the actual sum total of the cost of the urethane adhesive needed to perform the required repairs, not to exceed \$60.00 USD, \$85.00 CAD.

** The amount identified in “Net Item” should represent the actual sum total of the cost of the connector terminals, if needed, to perform the required repairs, not to exceed \$20.00 USD, \$28.00 CAD.

CUSTOMER NOTIFICATION – For US and Canada

General Motors will notify customers of this program on their vehicle (see copy of customer letter included with this bulletin).

CUSTOMER NOTIFICATION – For Export

Letters will be sent to known owners of record located within areas covered by the US National Traffic and Motor Vehicle Safety Act. For owners outside these areas, dealers should notify customers using the attached sample letter.

DEALER PROGRAM RESPONSIBILITY

All unsold new vehicles in dealers' possession and subject to this program must be held and inspected/repaired per the service procedure of this program bulletin before customers take possession of these vehicles. Dealers are to service all vehicles subject to this program at no charge to customers, regardless of mileage, age of vehicle, or ownership, through May 31, 2015.

Customers who have recently purchased vehicles sold from your vehicle inventory, and for which there is no customer information indicated on the involved vehicle listing, are to be contacted by the dealer. Arrangements are to be made to make the required correction according to the instructions contained in this bulletin.

A copy of the customer letter is provided in this bulletin for your use in contacting customers. Program follow-up cards should not be used for this purpose, since the customer may not as yet have received the notification letter.

In summary, whenever a vehicle subject to this program enters your vehicle inventory, or is in your facility for service through May 31, 2015, you must take the steps necessary to be sure the program correction has been made before selling or releasing the vehicle.



April 2013

Dear General Motors Customer:

We have learned that the windshield in your 2012 model year Buick Verano may not be completely sealed to the body at the lower left side of the windshield. Water could leak into the vehicle at this point and drip onto the body harness connector, causing corrosion on the terminals or shorting between terminals. Depending on the terminal(s) involved, it could cause one or more of the following conditions: automatic OnStar® emergency calls, flashing of the park brake light, rough engine operation, improper air conditioning system operation, illumination of the Service Engine Soon light, and other malfunctions.

Your satisfaction with your Buick Verano is very important to us, so we are announcing a program to prevent this condition or, if it has occurred, to fix it.

What We Will Do: Your GM dealer will perform a water test on the windshield to detect a water leak. If a leak is found, your dealer will reseal the area and perform another water test. If a water leak is still present, the windshield will be reinstalled. Also, if evidence of a leak is found, the connectors will be inspected to determine if any terminals are corroded. Any corroded terminals will be replaced. This service will be performed for you at **no charge until May 31, 2015**. After that, any applicable warranty will apply.

What You Should Do: To limit any possible inconvenience, we recommend that you contact your dealer as soon as possible to schedule an appointment for this repair. By scheduling an appointment, your dealer can ensure that the necessary parts will be available on your scheduled appointment date.

If you have any questions or concerns that your dealer is unable to resolve, please contact the appropriate Customer Assistance Center at the number listed below.

| Division | Number | Text Telephones (TTY) |
|-----------------------|----------------|-----------------------|
| Buick | 1-800-521-7300 | 1-800-832-8425 |
| Guam | 65-6267-1752 | |
| Puerto Rico – English | 1-800-496-9992 | |
| Puerto Rico – Español | 1-800-496-9993 | |
| Virgin Islands | 1-800-496-9994 | |

Courtesy Transportation: If your vehicle is within the New Vehicle Limited Warranty, your dealer may provide you with shuttle service or some other form of courtesy transportation while your vehicle is at the dealership for this repair. Please refer to your Owner Manual and your dealer for details on Courtesy Transportation.

We sincerely regret any inconvenience or concern that this situation may cause you. We want you to know that we will do our best, throughout your ownership experience, to ensure that your Buick Verano provides you many miles of enjoyable driving.

Jim Moloney
General Director,
Customer and Relationship Services