



Service Bulletin



SERVICE UPDATE

SUBJECT: Service Update for Inventory and Customer Vehicles
Product Enhancements – Interior Trim
Expires with Base Warranty

MODELS: 2013 Cadillac XTS

The Part Information section has been revised to include an additional part number for the felt. Steps 5 and 9 in the service procedure have been revised. Please discard all copies of bulletin 12250.

This service update includes vehicles in dealer inventory and customer vehicles that return to the dealership for any reason. This bulletin will expire at the end of the involved vehicle's New Vehicle Limited Warranty period.

PURPOSE

This bulletin provides a service procedure to inspect and/or repair vehicle interior concerns that may impact customer satisfaction on **certain** 2013 model year Cadillac XTS vehicles.

- Replace the driver and front passenger seat track cover. The cover may not be fully secure.
- Inspect and, if necessary, replace the driver and/or passenger side center (B) pillar trim panels. The trim panels may not be secure.
- Inspect and, if necessary, reseal the front console cup holder. The holder may not be seated properly.
- Modify the 5 windshield defroster grille front plastic tabs. The tabs may not have a large enough interference fit and could cause a buzz or rattle sound.
- Inspect and, if necessary, repair or replace the IP storage compartment. The bin by the driver's left knee may be noisy or not open properly.
- Inspect and, if necessary, replace the floor console storage bin latch. The console may not open.
- Inspect, and if necessary, replace the windshield multifunction sensor mount bracket cover. The retention features may be damaged.

This service procedure should be completed as soon as possible on involved vehicles currently in dealer inventory and customer vehicles that return to the dealer for any type of service during the New Vehicle Limited Warranty coverage period.

VEHICLES INVOLVED

All involved vehicles are identified by VIN in the Global Warranty Management System – Investigate Vehicle History Application. Dealership technicians should always check this site to confirm vehicle involvement prior to beginning any required inspections and/or repairs. It is important to routinely use this tool to verify eligibility because not all similar vehicles may be involved regardless of description or option content.

Additionally, a list of involved vehicles currently in dealer inventory is available on the “Service Update Bulletin Information” link under the “Service” tab in GM GlobalConnect (US) or attached to the GlobalConnect message (Canada) used to release this bulletin. Customer vehicles that return for service, for any reason, and are still covered under the vehicle's base warranty should also be checked for vehicle eligibility.

PART INFORMATION

Note: All vehicles will require the seat track covers. Because very few vehicles will require the replacement of the center pillar lower trim panel, windshield multifunction sensor mount bracket cover, or IP knee bolster, please order parts only after the inspection determines replacement is necessary.

Parts required to complete this service update are to be obtained from General Motors Customer Care and Aftersales (GMCC&A). Please refer to your “involved vehicles listing” before ordering parts. Normal orders should be placed on a DRO = Daily Replenishment Order. In an emergency situation, parts should be ordered on a CSO = Customer Special Order.

Part Number	Description	Quantity/ Vehicle
23123126	COVER, D/SEAT OTR ADJR TRK FRT FIN (BLACK)	1
23123131	COVER, P/SEAT OTR ADJR TRK FRT FIN (BLACK)	1
23123127	COVER, F/SEAT OTR ADJR FRT FIN (SHALE)	1
23123132	COVER, F/SEAT OTR ADJR FRT FIN (SHALE)	1
23123128	COVER, D/SEAT OTR ADJR TRK FRT FIN (TITANIUM)	1
23123133	COVER, P/SEAT OTR ADJR TRK FRT FIN (TITANIUM)	1
23123129	COVER, D/SEAT OTR ADJR TRK FRT FIN (PLATINUM)	1
23123134	COVER, P/SEAT OTR ADJR TRK FRT FIN (PLATINUM)	1
23153805	LATCH, F/FLR CNSL A/RST (CHROME)	1 (If Req'd)
KT13486* (30 mm x 10 ft roll) or KT13487* (2-8x10 in. sheets) Obtain from Kent Automotive	Kent Automotive BRS (Felt) Tape Roll (will service 15 vehicles) or Kent Automotive BRS (Felt) Sheet (will service 20 vehicles)	As Needed (Submit as Net Item)

* Contact Kent Automotive at 1-888-937-5368 or www.kent-automotive.com. **Do not order from GMCC&A.** We believe this source and their products to be reliable. There may be additional manufacturers of such products/materials. General Motors does not endorse, indicate any preference for, or assume any responsibility for the products or material from this firm or for any such items that may be available from other sources.

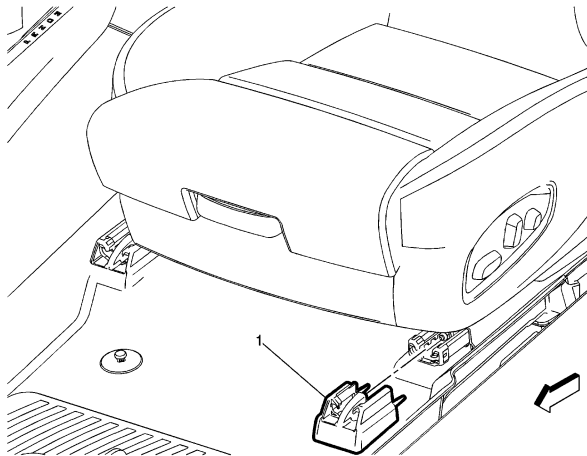
SERVICE PROCEDURE

2755689

1. Remove the driver and passenger seat outer track front covers (1). Refer to *Front Seat Track Cover Replacement* in SI.
2. Install new driver and passenger seat outer track front covers (1). Refer to *Front Seat Track Cover Replacement* in SI.



3257856

3. Inspect driver and passenger side center pillar trim panels to determine if the panels fit loose or have a gap between the lower and upper center pillar trim panels.
 - If the center pillar trim panels are not loose and no gap is present between the upper and lower center-pillar trim panels, proceed to step 4.
 - If the lower center pillar trim panels are loose and there is a gap between the upper and lower center pillar trim panels, replace the lower center pillar trim panel (s). Refer to *Center Pillar Lower Trim Panel Replacement* in SI.



2964017

4. Inspect the condition and function of the console cup holder door assembly. The inner and outer portions of the console cup holder door cover may not be snapped together. Pinch the two corners of the door if they are separated to engage and snap fit the retention features.

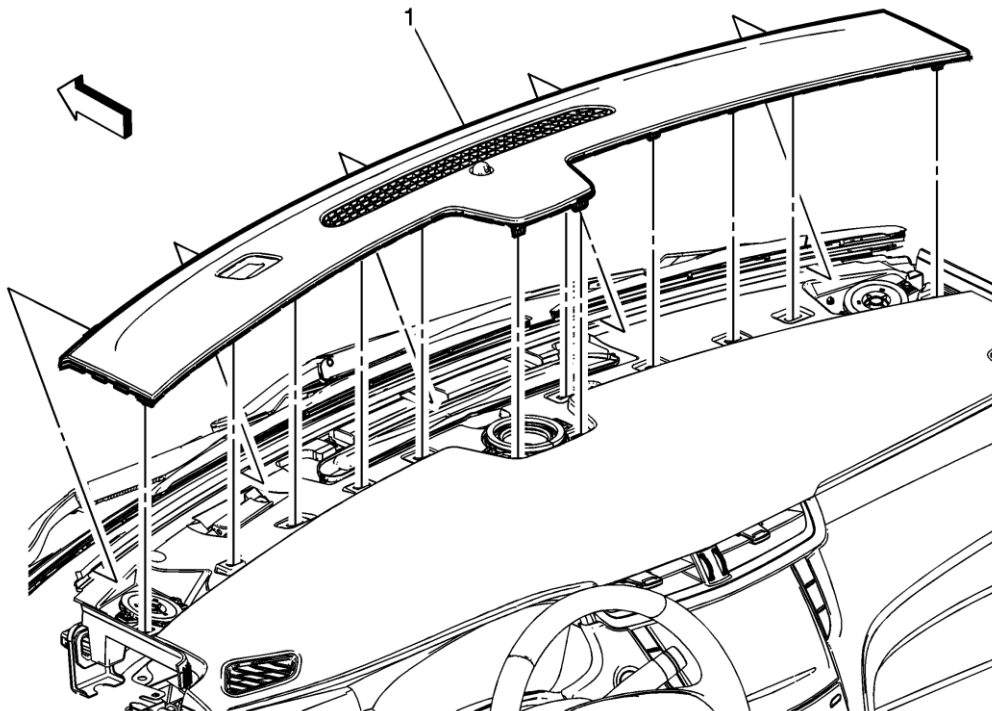

2759601

Note: Contrary to what the replacement procedure in SI states, the windshield garnish moldings do not require removal.

5. Remove the windshield defroster grille. Use a flat bladed plastic trim tool to release the 12 retainers to prevent damage to the instrument panel upper trim panel.
6. Place the windshield defroster grille on a clean level surface with the backside facing up.
7. Using Kent Automotive BRS (Felt) Tape, P/N KT13486 or Sheet, KT13487, cut five 15 mm x 60 mm strips.



3257797

8. Add the felt to the five windshield defroster grille front plastic tabs as shown. Completely wrap each tab ensuring the felt tape covers the rib near the metal screen.
9. Install the windshield defroster grille.
10. Locate the IP storage compartment.
11. Activate the IP storage compartment release mechanism 10 times to check the operation of the IP storage compartment.
 - If the IP storage compartment does NOT make noise or ratchet while the IP storage compartment door opens or closes, proceed to step 12.
 - If the IP storage compartment does make noise or ratchet while the IP storage compartment door opens or closes, proceed to *IP Storage Compartment Door Binds or Opens Very Slowly* or *IP Storage Compartment Door Opens Very Fast and/or Creates Zip Noise* in this bulletin.

IP Storage Compartment Door Binds or Opens Very Slowly

Note: This procedure should move the rack upward slightly to release excessive engagement of rack and pinion gears.

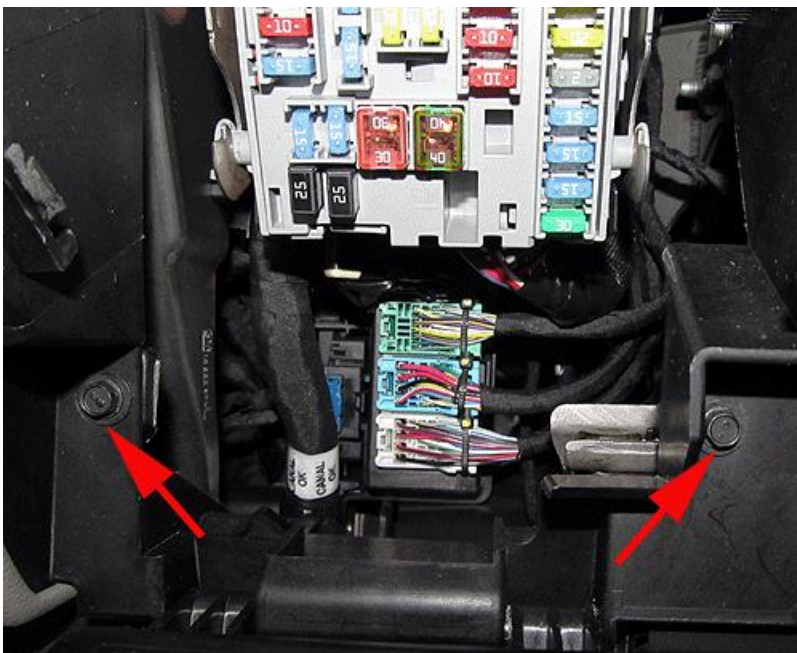

3258653

1. Open bin door with release tabs.
2. Loosen two screws.

3. While pulling downward on left side, tighten the left screw first and then tighten the right screw.

Note: If the bin door is still slow, then repeat steps 2-3, but add an upward push at the bottom right side BEFORE tightening the right screw. Replace the IP storage compartment if the adjustment does not correct the condition. Refer to *Instrument Panel Knee Bolster Replacement* in SI.

IP Storage Compartment Door Opens Very Fast and/or Creates Zip Noise

Note: This procedure should move the rack downward slightly to create more engagement of the rack and pinion gears.

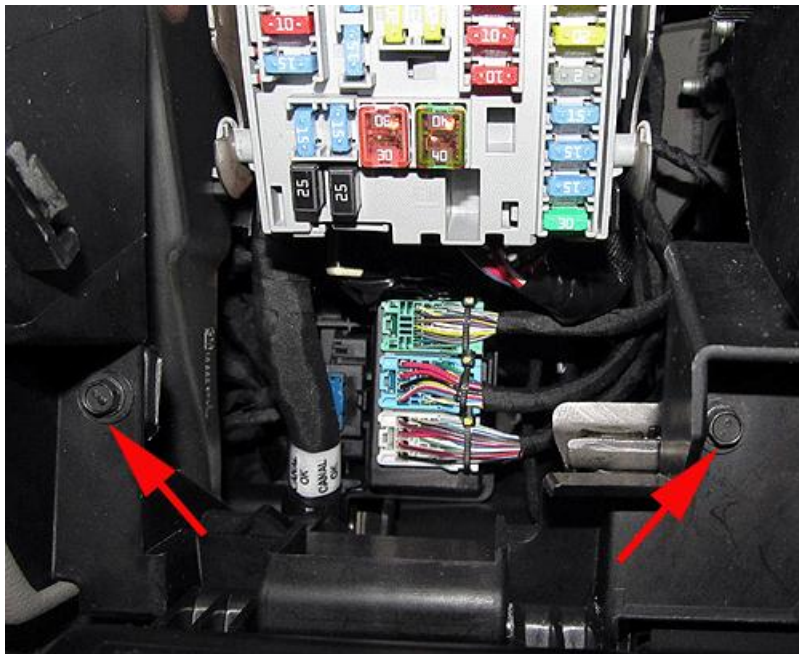

1. Open bin door with release tabs.
2. Ensure pinion gear is seated.
3. Loosen two screws.
4. While pulling downward on the right side, tighten the right screw first and then the left screw.

Note: Replace the IP storage compartment if the adjustment does not correct the condition. Refer to *Instrument Panel Knee Bolster Replacement* in SI.

12. Locate the floor console storage bin.
13. Open and close the floor console storage bin door by pressing the latch button.

14. Pull outward lightly on the latch button to determine if the latch button disengages from the floor console.
 - If the floor console door opens and closes properly and the latch button does NOT disengage or separate from the floor console, proceed to step 15.
 - If the floor console door does NOT open and/or the latch button disengages or separates from the floor console, replace the latch button with a new design latch button. Pull the latch button outward and away from the floor console to completely remove the latch button. Install the new latch button into the latch button cavity.



3258661

15. Locate the windshield multifunction sensor mount bracket cover. The inside rearview mirror arm protrudes through the center of the windshield multifunction sensor mount bracket cover.
16. Gently rock the windshield multifunction sensor mount bracket cover in a cross-car direction. The cover should feel solid and not separate into two halves or fall off the windshield.
 - If the windshield multifunction sensor mount bracket cover does not separate into two halves or fall off the windshield, no further action is required.
 - If the windshield multifunction sensor mount bracket cover does separate into two halves or falls off the windshield, proceed to step 17.

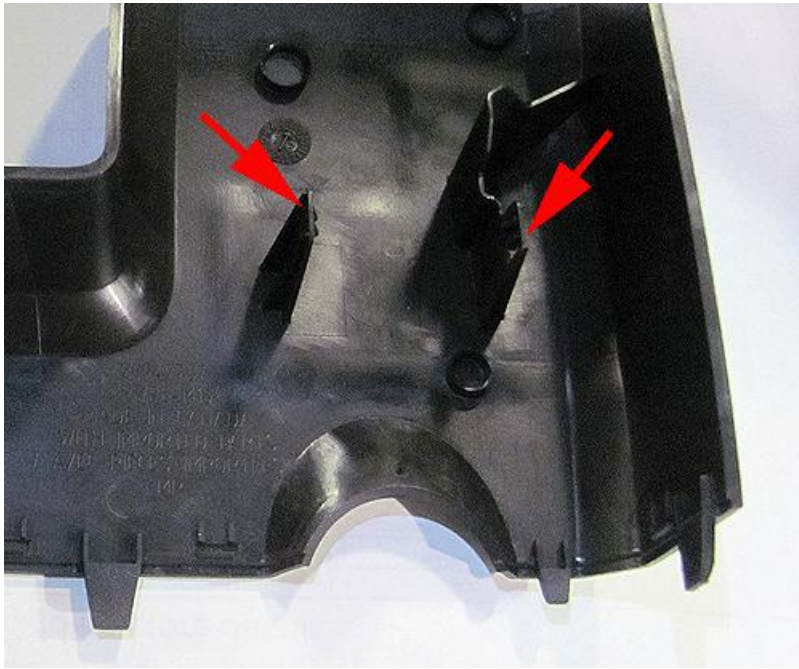

3258663

17. Remove the windshield multifunction sensor mount bracket cover and inspect the molded-in plastic clips located on the inside of the cover. Ensure the plastic clips are not bent or damaged. Straighten the bent clips and reinstall the windshield multifunction sensor mount bracket cover. Proceed to step 18. If the plastic clips are broken or badly damaged, replace the windshield multifunction sensor mount bracket cover. Proceed to step 18.



3258669

18. Inspect the rain sensor harness routing. Ensure the rain sensor harness (1) is routed along the side of the humidity sensor. Also ensure that the harness is routed inside of the “U” shaped bracket (2). Refer to the illustration. Tuck excess harness in tight along the side of the humidity sensor.
19. Turn inside rearview mirror lengthwise with the car.

20. Position the upper and lower windshield multifunction sensor mount bracket covers around the inside rearview mirror arm.

Note: Ensure the windshield multifunction sensor mount bracket cover locking tabs do NOT get bent during installation of the cover.

21. Align covers together and snap the upper and lower covers together, ensuring the covers are fully joined on all sides.
22. Seat the lower portion of the cover to the left side of the humidity sensor.
23. With both sides of the lower cover in place, push the lower cover into the windshield until a click noise is heard from the left and right side of the cover.
24. Push the upper portion of the cover into the windshield until a click noise heard from the left and right side of the cover.
25. Inspect the fit of the windshield multifunction sensor mount bracket cover. Ensure the cover is fully seated to the bracket with no gaps present.

WARRANTY TRANSACTION INFORMATION

Submit a transaction using the table below.

Labor Code	Description	Labor Time	Net Item
V2746	Inspect Vehicle, Replace Seat Track Outer Covers, Secure Cup Holder, Modify Windshield Defroster Grille Tabs	0.7	*
	Add: Replace Center (B) Pillar Trim Panel(s)	0.2	
	Add: Adjust IP Storage Compartment	0.1	
	Add: Adjust IP Storage Compartment Door & Replace IP Storage Compartment	0.7	
	Add: Replace Floor Console Storage Bin Latch	0.1	
	Add: Repair or Replace Windshield Multifunction Sensor Mount Bracket Cover	0.2	

* The amount identified in "Net Item" should represent the actual sum total of the BRS (felt) needed to perform the required repair, if necessary, not to exceed \$1.50 USD, \$2.80 CAD.

DEALER PROGRAM RESPONSIBILITY

Whenever a vehicle subject to this service update enters your vehicle inventory, or is in your facility for service in the future, and the vehicle is still covered under the New Vehicle Limited Warranty, you must take the steps necessary to be sure the service update correction has been made before selling or releasing the vehicle.

