



# Recall Bulletin



## PRODUCT SAFETY RECALL

**SUBJECT:** Power Window Master Switch Failure

**MODELS:** 2009 Pontiac Vibe

The Part Information section of this bulletin has been revised. Part number 19205538 has been put on part restriction. Please discard all copies of bulletin 12071.

### CONDITION

Toyota has decided that a defect, which relates to motor vehicle safety, exists in **certain** 2009 model year Pontiac Vibe vehicles. Pontiac Vibe was manufactured by New United Motor Manufacturing (NUMMI), a joint venture between Toyota and GM.

The Power Window Master Switch assembly (PWMS assembly), which controls the windows for the driver and passengers, is located in the driver's door. The switches that control the passenger's windows in the PWMS assembly may overheat and possibly cause a fire.

### CORRECTION

Dealers are to inspect the PWMS assembly and apply a specialized grease that prevents the condition from occurring. In limited instances, based upon the results of the inspection, the PWMS assembly circuit board may also be replaced.

### VEHICLES INVOLVED

All involved vehicles are identified by Vehicle Identification Number on the Investigate Vehicle History screen in GM Global Warranty Management system. Dealership service personnel should always check this site to confirm vehicle involvement prior to beginning any required inspections and/or repairs. It is important to routinely use this tool to verify eligibility because not all similar vehicles may be involved regardless of description or option content.

For dealers with involved vehicles, a listing with involved vehicles containing the complete vehicle identification number, customer name, and address information has been prepared and will be provided to dealers through the GM GlobalConnect Recall Reports. Dealers will not have a report available if they have no involved vehicles currently assigned.

The listing may contain customer names and addresses obtained from Motor Vehicle Registration Records. The use of such motor vehicle registration data for any purpose other than follow-up necessary to complete this recall is a violation of law in several

states/provinces/countries. Accordingly, you are urged to limit the use of this report to the follow-up necessary to complete this recall.

### PART INFORMATION

Parts required to complete this recall are to be obtained from General Motors Customer Care and Aftersales (GMCC&A). Please refer to your “involved vehicles listing” before ordering parts. Part number 19205538 is currently on TAC restriction and would need to be processed through TAC with a TAC case prior to release. All other parts can be obtained through normal orders placed on a DRO = Daily Replenishment Order. In an emergency situation, parts should be ordered on a CSO = Customer Special Order.

Part Number	Description	Quantity/Vehicle
19205538	BOARD,FRT S/D LK ACTR CIRC	1 (if req'd)
19205540	GREASE, MULTI-PURPOSE (one tube will service 15 vehicles)	As Needed (submit as Net Item)
19205539	APPLICATOR, GREASE (one time purchase only – will be used for all vehicles)	1 (can be used for all vehicles)
19205541	BOLT,FRT S/D WDO SW	3

### SERVICE PROCEDURE

#### **Preliminary Accessory Switch Operation Check**

Check the following operations of the accessory switch:

- Lock and unlock switch operation
- Up and down operation for each window
- Automation function of AUTO switch
- Window lock switch operation
- Illumination of “AUTO” on automatic switch (headlights must be on to confirm)

If any of the above operations do not perform correctly, diagnose and repair as outlined in SI.

**Note:** If an issue is found in a component other than the accessory switch, the repair of the component WILL NOT be covered under this campaign.

#### **Accessory Switch Inspection**

**Important:** Replace the accessory switch assembly ONLY if:

- Damage (hole or deformation) is visible on the outside of the switch housing.
- Damage is confirmed on the inside of the housing preventing smooth operation of the switch levers.
- Damage is confirmed on the base to which the circuit board mounts.

If none of these conditions are found during the inspection, DO NOT replace the switch assembly. The accessory switch assembly DOES NOT need to be replaced if the visible damage is isolated to the circuit board. A very small number of vehicles will require switch assembly replacement.

1. Remove the accessory switch assembly.
  - 1.1 Using a taped flat bladed tool, gently disengage the clip and the seven retainers of the side door accessory switch mounting plate, and slide rearward from the front side door trim.
  - 1.2 Disconnect the electrical connector.
  - 1.3 Remove the three screws and the accessory switch from the mounting plate.

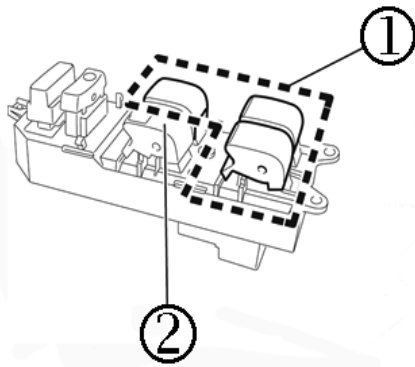

3021144

2. Check all switches (1) that do not have AUTO function (2) for the catching condition.

**Note:**

- All switches that ARE NOT AUTO MUST be inspected.
- The switches MUST be operated slowly otherwise the catching cannot be noticed.
- The switches MUST be operated with two fingers otherwise the catching cannot be noticed.
- The switches may feel unsmooth this DOES NOT mean the switch is no good.



3021149

OK-Good  
 NG-No Good

3. Operate each switch in the up direction, and then slowly return the switch using two fingers.

4. Operate each switch in the down direction, and then slowly return the switch using two fingers.
  - If none of the switches are catching, proceed to the Check Resistance of the Switches procedure in the bulletin.
  - If one or more of the switches are catching, replace the accessory switch circuit board. For removal, refer to steps 1-4 of the Check Resistance of the Switches procedure in this bulletin. For installation, refer to the Switch Reassembly procedure in this bulletin. DO NOT reuse the screws that have been removed, new one-way screws MUST be used.

### Check Resistance of the Switches

#### Important:

- Removing the lock button while it is turned ON may damage the switch.
- To prevent damage, Do Not use tools.

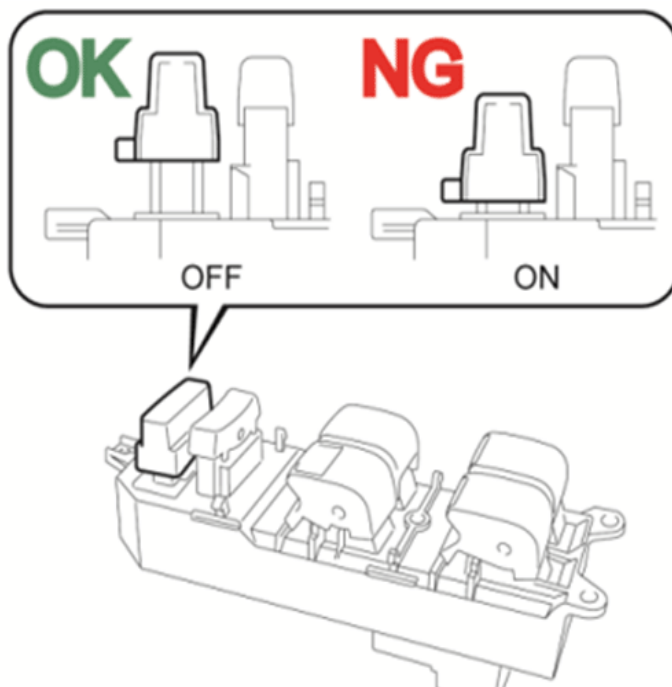

3021150

OK-Good  
NG-No Good

1. Turn the window lock switch to the OFF position.
2. Pull the button up to remove it from the switch assembly.

Important: DO NOT reuse the screws that have been removed, new one-way screws MUST be used.
3. Remove the switch circuit board screws. Discard the screws.

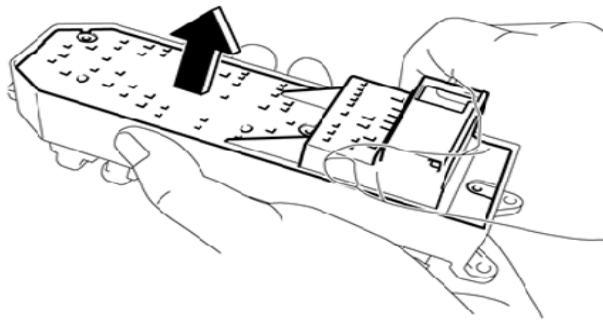

3021151

4. Lift the switch board straight up to remove it.

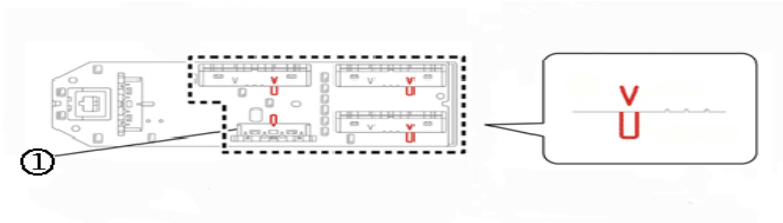

3021153

5. Align each switch pin with the “V” mark on all switches that do not have AUTO function.

6. Align the switch pin with the center line on all AUTO function switches.

**Important:**

- If the AUTO switches are not aligned correctly, the readings may be inaccurate
- The switches MUST be in this position when checking the resistance. This is the OFF position. If the switch is in any other position, the readings will be incorrect.
- ALL switches that ARE NOT AUTO MUST be checked.

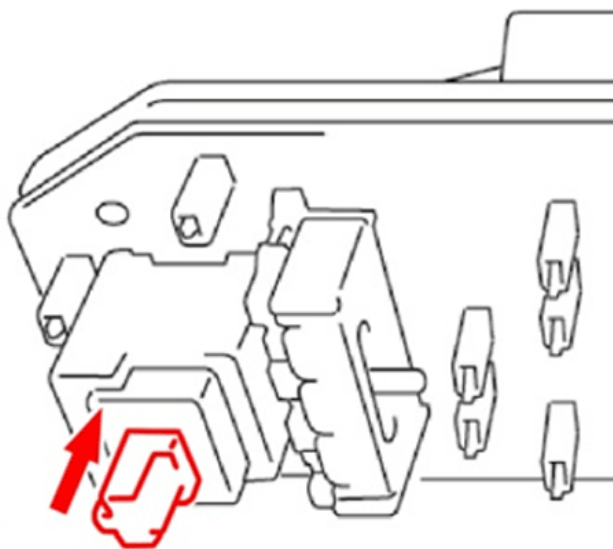

3021155

7. Push the window lock button so that it is in the down position.

**Important:** If the window lock button is not in the down position, the readings may be inaccurate.

8. Perform the ZERO calibration function on the DVOM.

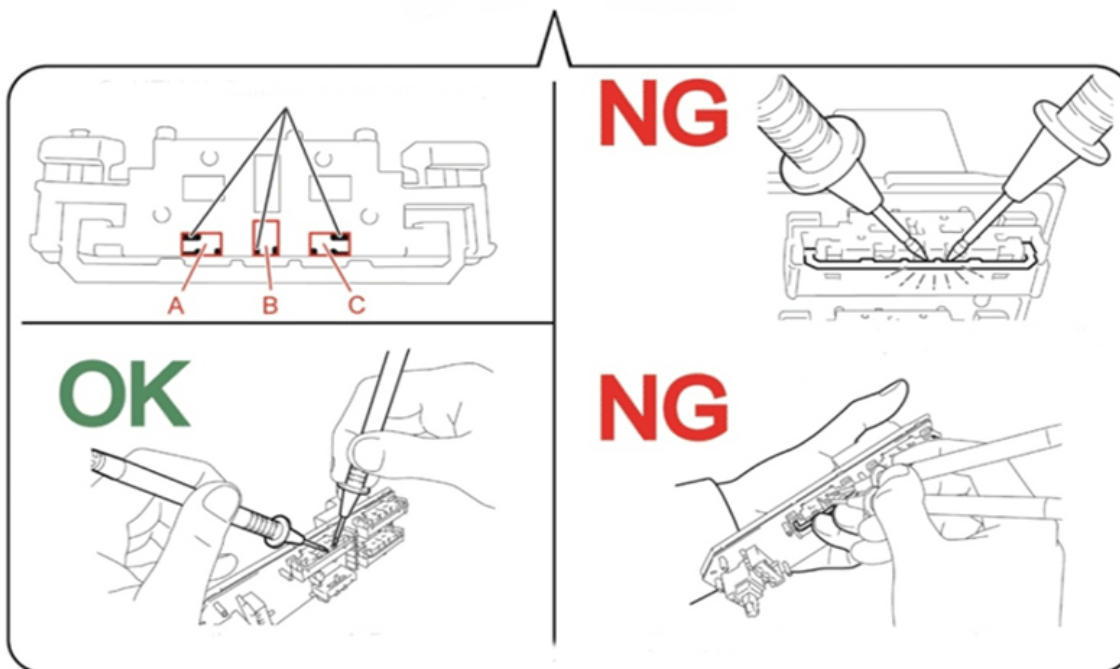
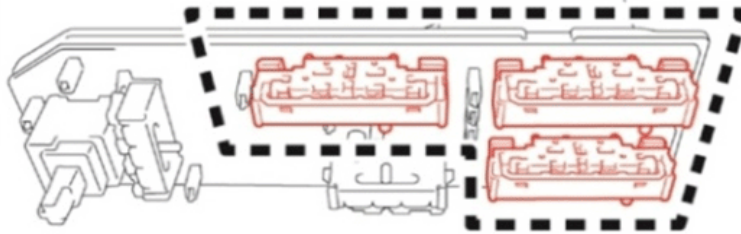

3021162

OK-Good  
NG-No Good

9. Measure the resistance between points A-B and points B-C.

**Important:**

- If the ZERO calibration function is not performed, the readings may be inaccurate.
- Set the DVOM to the maximum resistance range.
- DO NOT touch any metal other than the points A, B, C on the circuit board when checking resistance.

- The points being checked are small, confirm the probes are contacting the correct points
- ALL switches that ARE NOT AUTO MUST be checked.

10. Record the resistance readings.

- If the resistance value for ALL switches is infinite, fill the switches with grease. Refer to the Grease Application procedure in this bulletin.
- If one or more resistance value IS NOT infinite, replace the accessory switch circuit board. Refer to the Switch Reassembly procedure in this bulletin.

**Important:** Replace the accessory switch assembly ONLY if:

- Damage (hole or deformation) is visible on the outside of the switch housing.
- Damage is confirmed on the inside of the housing preventing smooth operation of the switch levers.
- Damage is confirmed on the base to which the circuit board mounts.

If none of these conditions are found during the inspection, DO NOT replace the switch assembly. The accessory switch assembly DOES NOT need to be replaced if the visible damage is isolated to the circuit board. A very small number of vehicles will require switch assembly replacement.

### Grease Application

**Note:**

- Approximately 0.5 to 0.9 ml of grease will be needed for each circuit board assembly.
- One tube contains 15 ml of grease and will remedy approximately 15 vehicles.



3021171

1. With the cap on, shake the tube of grease to confirm the grease is at the mouth of the tube.

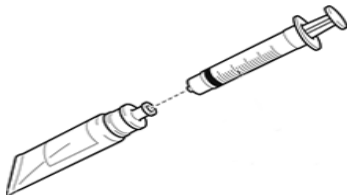

3021172

2. Attach the adapter to the tube of grease.

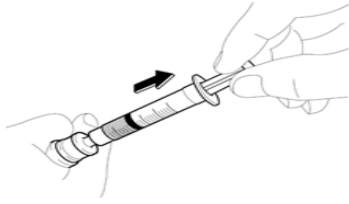

3021173

- 3. Screw the syringe onto the adapter.
- 4. Gently squeeze the tube while pulling up on the plunger to fill the syringe.

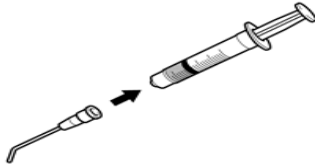

3021176

- 5. Remove the syringe from the adapter and screw on the nozzle.

**Important:** ALL switches that ARE NOT AUTO MUST be greased.

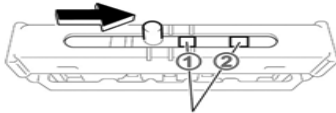

3021177

- 6. Position the switches. Slide the switch pins all the way to the front.

**Note:** The grease may overflow through the back side of the switch, this is acceptable.

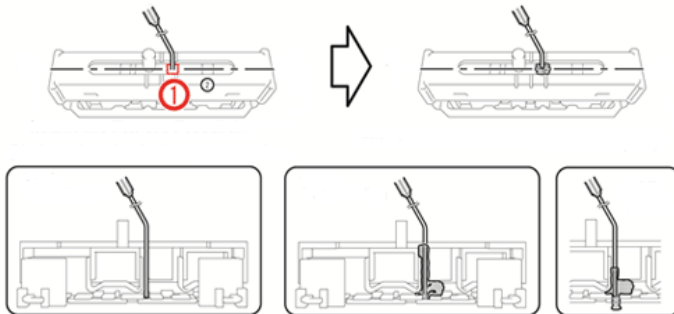

3021179



- 7. Insert the nozzle in hole 1 as far as it will go and fill the hole with grease. Fill the switch until the grease begins to slightly overflow.

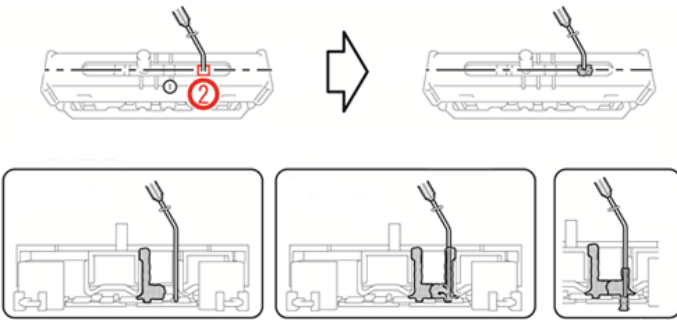

3021195

- 8. Insert the nozzle in hole 2 as far as it will go and fill the hole with grease. Fill the switch until the grease begins to slightly overflow.
- 9. Wipe up any excess grease from the switches.

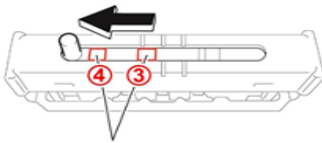

3021200

- 10. Reposition the switches. Slide the switch pins all the way to the rear.

**Note:** The grease may overflow through the back side of the switch, this is acceptable.

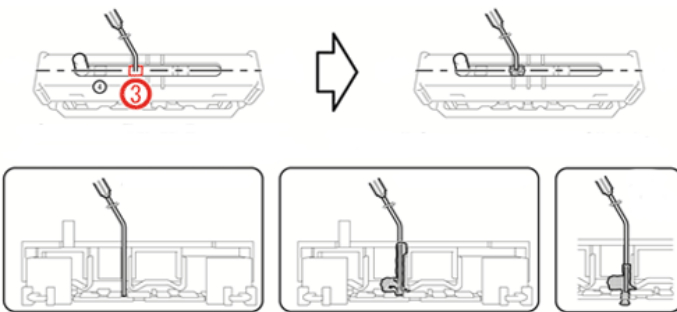

3021204

- 11. Insert the nozzle in hole 3 as far as it will go and fill the hole with grease. Fill the switch until the grease begins to slightly overflow.

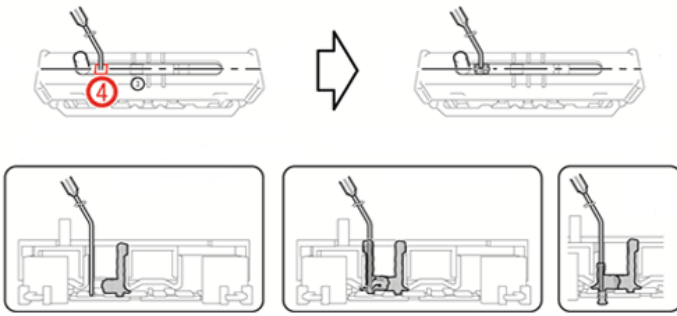

3021206

12. Insert the nozzle in hole 4 as far as it will go and fill the hole with grease. Fill the switch until the grease begins to slightly overflow.
13. Wipe up any excess grease from the switches.
14. Store the syringe set to be used on future vehicles. Store in a location free from dust and debris.

### Switch Reassembly

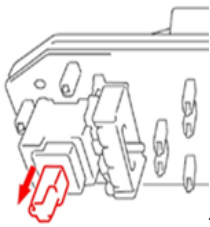

3021207

1. Place the window lock button in the up position.

**Important:** If the switch pins are not aligned, the switches will not operate correctly after reassembly.

2. Position the switches. Align all switch pins with the marks as shown in the illustration below.

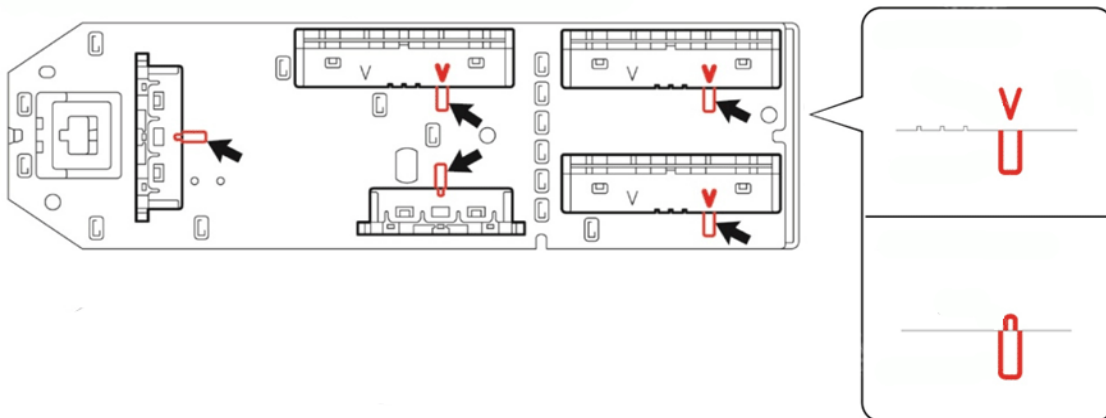

3021208

3. Carefully position the circuit board into the switch case avoiding misaligning the switch pins.

**Important:** DO NOT install the screws to secure the circuit board until completing the operation checks described below.

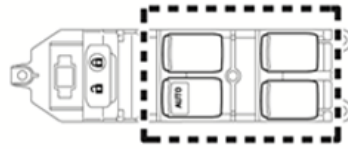

**OK**

**NG**

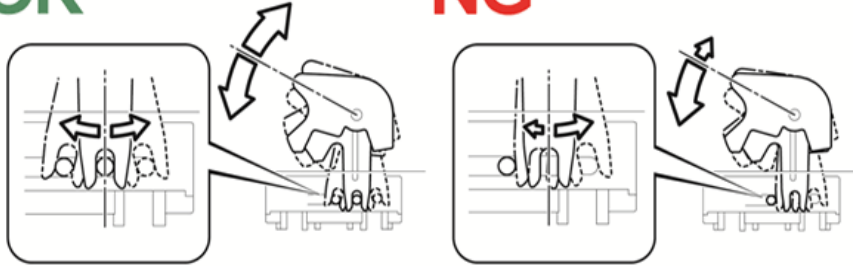

3021212

OK-Good  
NG-No Good

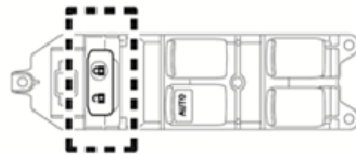

**OK**

**NG**

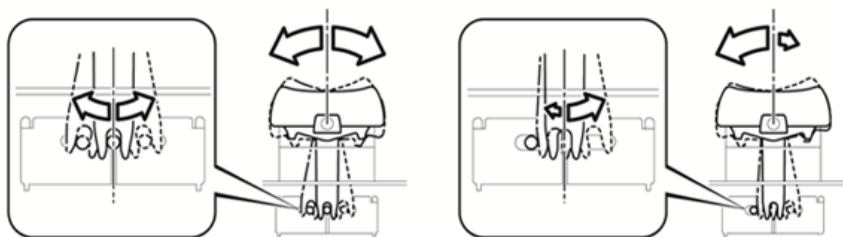

3021213

OK-Good  
NG-No Good

4. While holding the circuit board in the switch case, check the operation of the switches. The movement up/down and lock/unlock position should be equal in both directions.
  - If movement is equal in ALL switches, the circuit board is positioned correctly. Proceed to step 5.
  - If movement in one or more switch IS NOT equal, one or more switch pin is misaligned. Repeat steps 2-4.

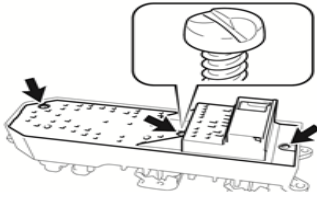

3021214

5. Install the one-way screws.

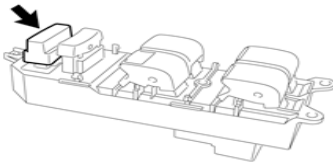

3021215

6. Install the window lock button. Press the lock button firmly until a snap is heard.
7. Install the accessory switch assembly to the mounting plate.
8. Install the three screws.
9. Connect the electrical connector.
10. Slide the side door accessory switch mounting plate forward to engage the clip and the seven retainers to the front side door trim.
11. Confirm the following operations of the accessory switch:
  - Lock and unlock switch operation
  - Up and down operation for each window
  - Automation function of AUTO switch
  - Window lock switch operation
  - Illumination of "AUTO" on automatic switch (headlights must be on to confirm)

### CUSTOMER REIMBURSEMENT - For US

Customer requests for reimbursement of previously paid repairs for the recall condition are to be submitted to the dealer by April 30, 2014, unless otherwise specified by state law. If this is not convenient for the customer, they may mail the completed Customer Reimbursement Request Form and all required documents to the GM Customer Assistance Center.

**All reasonable and customary costs to correct the condition described in this bulletin should be considered for reimbursement. Any questions or concerns should be reviewed with your GM representative prior to processing the request.**

When a customer requests reimbursement, they must provide the following:

- A completed Customer Reimbursement Request Form. This form is mailed to the customer or can be obtained through GM GlobalConnect.
- The name and address of the person who paid for the repair.
- Paid receipt confirming the amount of the repair expense, a description of the repair, and the person or entity performing the repair.

**IMPORTANT:** GM requires dealers to approve or deny a reimbursement request within 30 days of receipt. If a reimbursement request is approved, the dealer should immediately issue a check to the customer and submit an appropriate warranty transaction for the incurred expense. If a reimbursement request is denied, the dealer MUST provide the customer with a clear and concise explanation, in writing, as to why the request was denied. The bottom portion of the Customer Reimbursement Request Form may be used for this purpose. If the denial was due to missing documents, the customer can resubmit the request when the missing documents are obtained, as long as it is still within the allowed reimbursement period.

Warranty transactions for customer reimbursement of previously paid repairs are to be submitted as required by GM Global Warranty Management. Additional information can also be found in Warranty Administration Bulletin 11-00-89-004.

#### CUSTOMER REIMBURSEMENT - For Canada

Customer requests for reimbursement of previously paid repairs to correct the condition described in this bulletin are to be submitted to the dealer prior to or by April 30, 2014.

When a customer requests reimbursement, they must provide the following:

- Proof of ownership at time of repair.
- Original paid receipt confirming the amount of unreimbursed repair expense(s) (including Service Contract deductibles), a description of the repair, and the person or entity performing the repair.

All reasonable and customary costs to correct the condition described in this bulletin should be considered for reimbursement. Any questions or concerns should be reviewed with your GM representative prior to processing the request.

**WARRANTY TRANSACTION INFORMATION**

Submit all transaction using the table below. All transactions should be submitted as a ZFAT transaction type, unless noted otherwise.

<b>Labor Code</b>	<b>Description</b>	<b>Labor Time</b>	<b>Net Item</b>
V2766	Switch Inspection and Replace Circuit Board	0.3	N/A
V2767	Switch Inspection, Resistance Check, and Replace Circuit Board	0.4	N/A
V2768	Switch Inspection, Resistance Check, and Grease Application	0.7	*
V2769**	Customer Reimbursement Approved	0.2	***
V2770	Customer Reimbursement Denied - For US dealers only	0.1	N/A
T5904****	One Time Charge for Grease Applicator	N/A	N/A

- \* Enter the actual cost of the grease required to complete the repair, not to exceed \$0.41 USD, \$0.25 CAD, plus applicable Mark-Up or Landed Cost (for Export).
- \*\* Customer reimbursement will not close this recall. The service procedure must also be performed on the vehicle.
- \*\*\* The amount identified in "Net Item" should represent the dollar amount reimbursed to the customer.
- \*\*\*\* The grease applicator required for this recall can be used to repair all involved vehicles. Dealers are to submit one time only for the purchase of the applicator.

**CUSTOMER NOTIFICATION**

General Motors will notify customers of this recall on their vehicle (see copy of customer letter included with this bulletin).

**DEALER RECALL RESPONSIBILITY** – For US (US States, Territories, and Possessions)

It is a violation of Federal law for a dealer to deliver a new motor vehicle or any new or used item of motor vehicle equipment (including a tire) covered by this notification under a sale or lease until the defect or noncompliance is remedied.

The US National Traffic and Motor Vehicle Safety Act provides that each vehicle that is subject to a recall of this type must be adequately repaired within a reasonable time after the customer has tendered it for repair. A failure to repair within sixty days after tender of a vehicle is prima facie evidence of failure to repair within a reasonable time. If the condition is not adequately repaired within a reasonable time, the customer may be entitled to an identical or reasonably equivalent vehicle at no charge or to a refund of the purchase price less a reasonable allowance for depreciation. To avoid having to provide these burdensome remedies, every effort must be made to promptly schedule an appointment with each customer and to repair their vehicle as soon as possible. In the recall notification letters, customers are told how to contact the US National Highway Traffic Safety Administration if the recall is not completed within a reasonable time.

**DEALER RECALL RESPONSIBILITY – All**

All unsold new vehicles in dealers' possession and subject to this recall must be held and inspected/repaired per the service procedure of this recall bulletin before customers take possession of these vehicles.

Dealers are to service all vehicles subject to this recall at no charge to customers, regardless of mileage, age of vehicle, or ownership, from this time forward.

Customers who have recently purchased vehicles sold from your vehicle inventory, and for which there is no customer information indicated on the dealer listing, are to be contacted by the dealer. Arrangements are to be made to make the required correction according to the instructions contained in this bulletin. A copy of the customer letter is provided in this bulletin for your use in contacting customers. Recall follow-up cards should not be used for this purpose, since the customer may not as yet have received the notification letter.

In summary, whenever a vehicle subject to this recall enters your vehicle inventory, or is in your dealership for service in the future, you must take the steps necessary to be sure the recall correction has been made before selling or releasing the vehicle.



April 2013

Dear General Motors Customer:

This notice is sent to you in accordance with the requirements of the National Traffic and Motor Vehicle Safety Act.

The Pontiac Vibe was manufactured by New United Motor Manufacturing, Inc. (NUMMI), a joint venture between Toyota and GM.

Toyota has decided that a defect, which relates to motor vehicle safety, exists in certain 2009 model year Pontiac Vibe vehicles. As a result, GM is conducting a safety recall. We apologize for this inconvenience. However, we are concerned about your safety and continued satisfaction with our products.

## **I M P O R T A N T**

- Your vehicle is involved in safety recall 12071.
- Schedule an appointment with your GM dealer.
- This service will be performed for you at **no charge**.

### **Why is your vehicle being recalled?**

The Power Window Master Switch assembly (PWMS assembly), which controls the windows for the driver and passengers, is located in the driver's door. The switches that control the passenger's windows in the PWMS assembly may overheat and possibly cause a fire.

### **What will we do?**

Your GM dealer will inspect the PWMS assembly and apply a specialized grease that prevents the condition from occurring. In a limited number of instances, based upon the results of the inspection, the PWMS assembly circuit board may also be replaced. This service will be performed for you at **no charge**. The inspection and application of the specialized grease will take approximately 1 hour. However, because of service scheduling requirements, it is likely that your dealer will need your vehicle for a longer period of time.

### **What should you do?**

You should contact your GM dealer to arrange a service appointment as soon as possible.

In the meantime, if the passenger window switches in the PWMS assembly begins to feel uneven or "notchy" when they are operated it may be an indication that your switch is not operating properly. Please make an appointment as soon as possible with your GM dealer to have the PWMS assembly inspected. If it is determined that the switch is not operating properly due to this condition, the assembly will be repaired at **no charge** to you.

Do not attempt to make repairs by applying commercially available chemicals (for example, lubricants or cleaners) into the PWMS assembly. Doing so may cause the PWMS assembly to smoke,



melt, or under some circumstances, cause a fire. In the event commercially available chemicals have already been applied to the PWMS assembly, please make an appointment with your dealer as soon as possible to have the PWMS assembly inspected.

**Did you already pay for this repair?**

If you have paid for repairs for the recall condition, please complete the enclosed form and present it to your dealer with all required documents. Working with your dealer will expedite your request, however, if this is not convenient, you may mail the completed form and all required documents to Reimbursement Department, PO Box 33170, Detroit, MI 48232-5170. The completed form and required documents must be presented to your dealer or received by the Reimbursement Department by April 30, 2014, unless state law specifies a longer reimbursement period. Even though you may have already had this condition corrected, you will still need to take your vehicle to your dealer for additional repairs.

**Do you have questions?**

If you have questions or concerns that your dealer is unable to resolve, please contact the appropriate Customer Assistance Center at the number listed below.

Division	Number	Text Telephones (TTY)
Pontiac	1-800-762-2737	1-800-833-7668
Guam	65-6267-1752	
Puerto Rico – English	1-800-496-9992	
Puerto Rico – Español	1-800-496-9993	
Virgin Islands	1-800-496-9994	

If after contacting your dealer and the Customer Assistance Center, you are still not satisfied we have done our best to remedy this condition without charge and within a reasonable time, you may wish to write the Administrator, National Highway Traffic Safety Administration, 1200 New Jersey Avenue, SE, Washington, DC 20590, or call the toll-free Vehicle Safety Hotline at 1.888.327.4236 (TTY 1.800.424.9153), or go to <http://www.safercar.gov>. The National Highway Traffic Safety Administration Campaign ID Number for this recall is 12V491.

Federal regulation requires that any vehicle lessor receiving this recall notice must forward a copy of this notice to the lessee within ten days.

Jim Moloney  
General Director,  
Customer and Relationship Services

Enclosure  
GM Recall #12071